

HIWIN®

MULTI-AXIS ROBOT

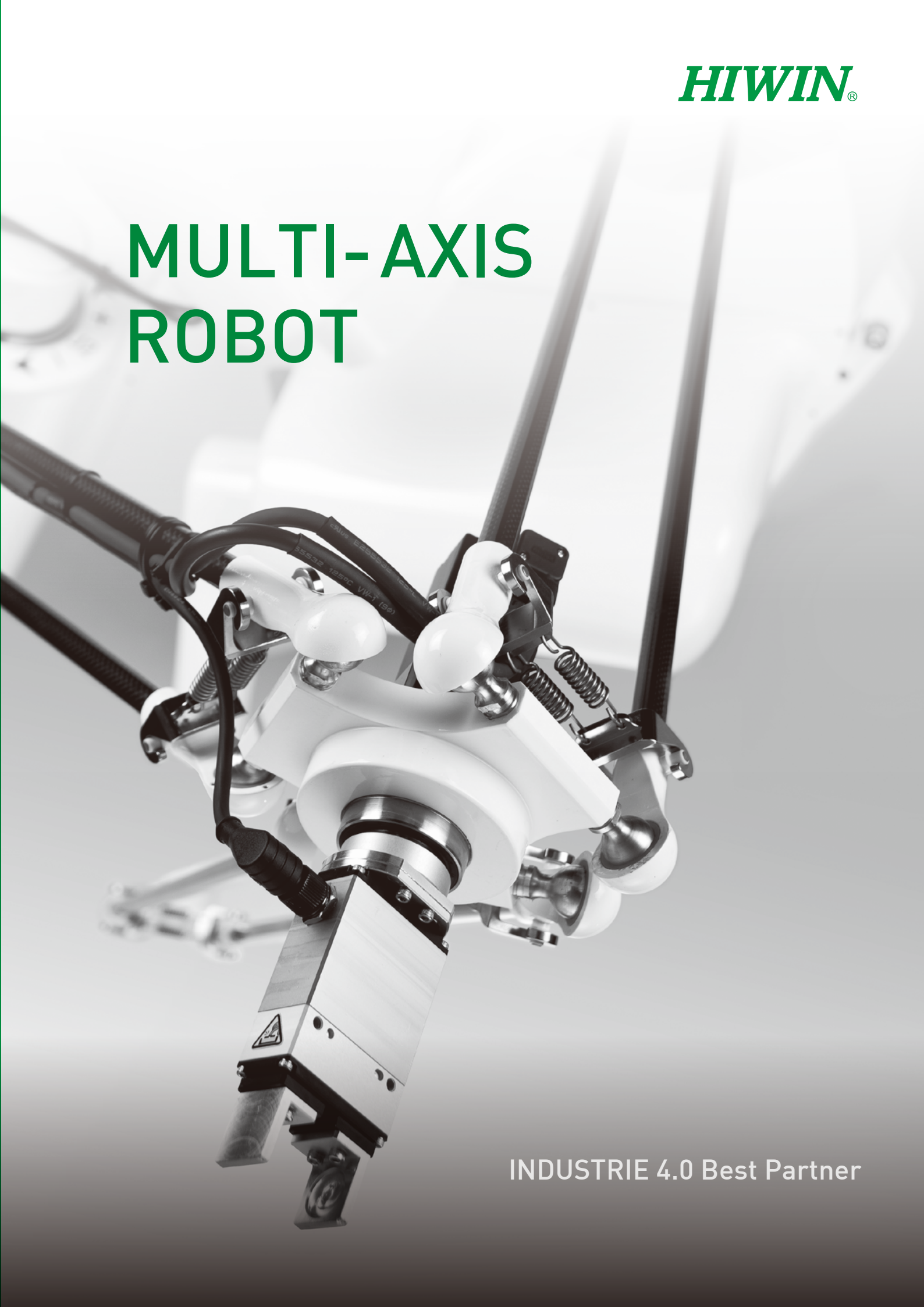

INDUSTRIE 4.0 Best Partner

Articulated Robot

RT605-GB RA605-GC ● NEW



RT605-710-GB

RA605-710-GC CE RoHS

Features

- A compact sized articulated robot with arm length and payload similar to a human arm, its flexible design makes it useful in application like assembly line, compact spaced equipments and can also be used in overhanging application to save space.

Application

- Assembly, dispensing, visual inspection, small components loading and unloading, upside down application.

Model	RT605-GB		RA605-GC	
Degrees of freedom	6			
Rated payload[kg]	5			
Maximum payload[kg]	7			
Max. reach radius[mm]	710	909	710	909
Working range [deg]	J1	±165		
	J2	+85 / -125		
	J3	+185 / -55		
	J4	±190		
	J5	±115		
	J6	±360		
Repeatability[mm]	±0.03	±0.04	±0.02	±0.03
Cycle time[s]*Note 1	0.5			
Weight[kg]	40	45	40	45
Protection rating	IP32		IP65	
Controller	RCT605-GB		RCA605-GC	
Tool pneumatic pipes	Two channels of pneumatic connection			
Safety/Environmental Standard	-		CE/RoHS2.0	

* Note 1: Based on a back-and-forth movement over a vertical distance of 25mm and a horizontal distance of 300mm.

Dimensions

Model / Dimensions	V _A	V _B	V _C	V _D	V _E	V _F	V _G	V _H	V _I	V _J
RT605-710-GB	650	710	1215	1055	272	67	338	R242	R304	R249
RT605-909-GB	848.1	909.8	1571	1254.8	334.2	24.7	438	R302.5	R439.8	R564.3
RA605-710-GC	650	710	1215	1055	272	67	338	R242	R304	R249
RA605-909-GC	848.1	909.8	1571	1254.8	334.2	24.7	438	R302.5	R439.8	R564.3

Unit:mm

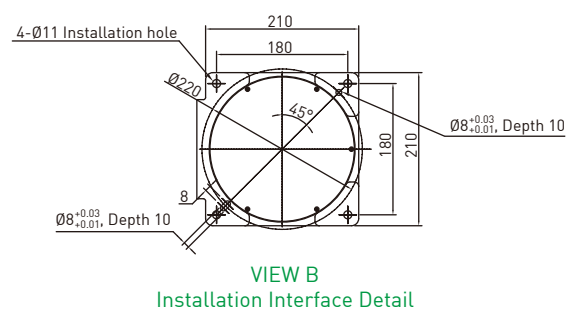
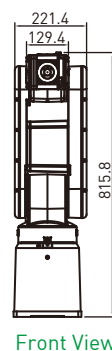
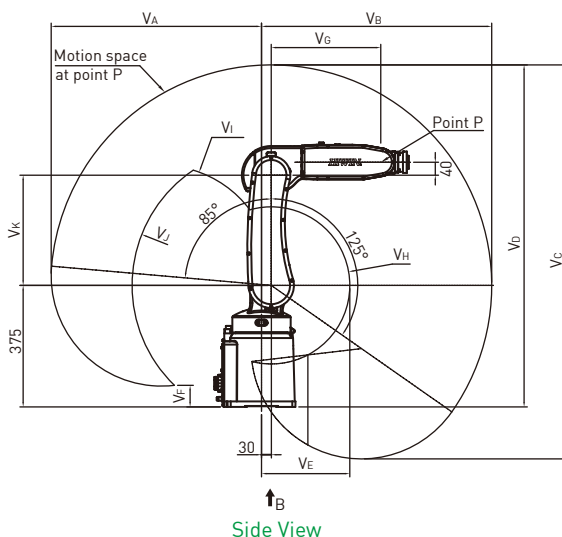
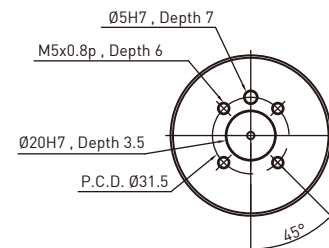
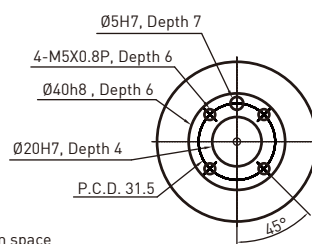
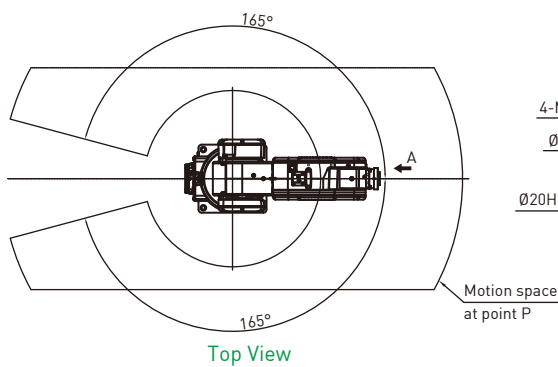

Articulated Robot

RA610-GC ● NEW



RA610-1476-GC



Features

- Slender and agile articulated robot with high degree-of-freedom, it can meet customers' optimal load and work range requirements. Its design is specially suitable for machine tending application and can also be integrated with vision system for material inspection.

Application

- Packaging, deburring, dispensing, visual inspection, loading and unloading.

Model	RA610-GC			
Degrees of freedom	6			
Rated payload[kg]	12	10	10	7
Maximum payload[kg]	14	12	12	9
Max. reach radius[mm]	1355	1476	1672	1869
Working range [deg]	J1	±170		
	J2	+95 / -150		
	J3	+185 / -85		
	J4	±190		
	J5	±135		
	J6	±360		
Repeatability[mm]	±0.05		±0.06	
Cycle time[s]*Note 1	1			
Weight[kg]	143	147	150	152
Protection rating	IP54(Wrist:IP65)			
Controller	RCA610-GC			
Tool pneumatic pipes	Two channels of pneumatic connection			
Safety/Environmental Standard	CE/RoHS2.0			

* Note 1: Based on a back-and-forth movement over a vertical distance of 25mm and a horizontal distance of 300mm.

Dimensions

Model / Dimensions	V _A	V _B	V _C	V _D	V _E	V _F	V _G	V _H	V _I	V _J
RA610-1355-GC	1075	1355	2343	1663	372.5	182	552	R232.5	R575	R688
RA610-1476-GC	1196	1476	2587	1785	368	304	678	R228	R697	R904
RA610-1672-GC	1392	1672	2979	1981	463	500	878	R323	R892	R951
RA610-1869-GC	1589	1869	3374	2178	630	697	1078	R490	R1089	R1129

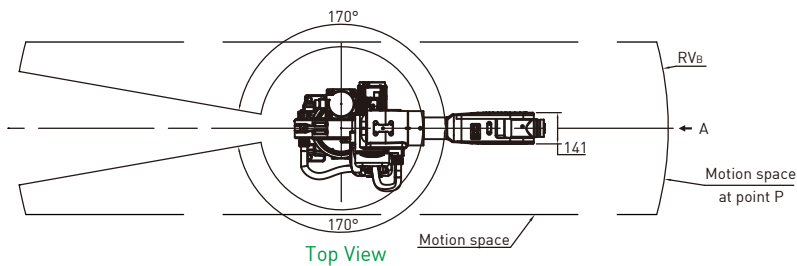

Unit:mm

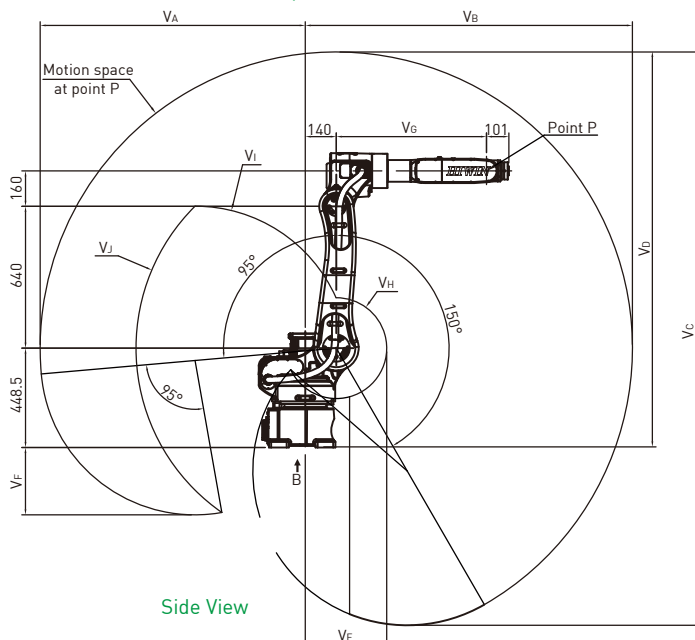

VIEW A
Mounting Flange Detail

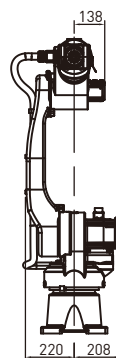

Front View

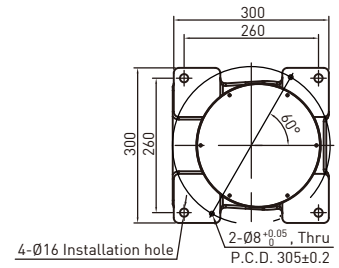

VIEW B
Installation Interface Detail

Articulated Robot RA620



RA620-1739

Features

- Strong and powerful articulated robot far beyond the scope of human working range and loading capacity, with a solid mechanical and practical software design, it is suitable for application like welding, polishing, grinding, palletizing and machine tending of large components.

Application

- Packaging, deburring, loading and unloading, welding, polishing, stacking.

freedom	6	
Rated payload[kg]	30	20
Maximum payload[kg]	33	23
Max. reach radius[mm]	1621	1739
Working range [deg]	J1	±180
	J2	+100 / -135
	J3	+190 / -80
	J4	±200
	J5	±130
	J6	±360
Repeatability[mm]	±0.06	
Cycle time[s]*Note 1	0.9	
Weight[kg]	226	230
Protection rating	IP54(Wrist:IP65)	
Controller	RCA620	
Tool pneumatic pipes	Three pneumatic solenoid valves connections	

* Note 1: Based on a back-and-forth movement over a vertical distance of 25mm and a horizontal distance of 300mm.

Dimensions

Model / Dimensions	V _A	V _B	V _C	V _D	V _E	V _F	V _G	V _H	V _I	V _J
RA620-1621	1321	1621	1996	721	443	310	685	R293	R701	R821
RA620-1739	1439	1739	2114	838	438	428	805	R288	R819	R906

Unit:mm

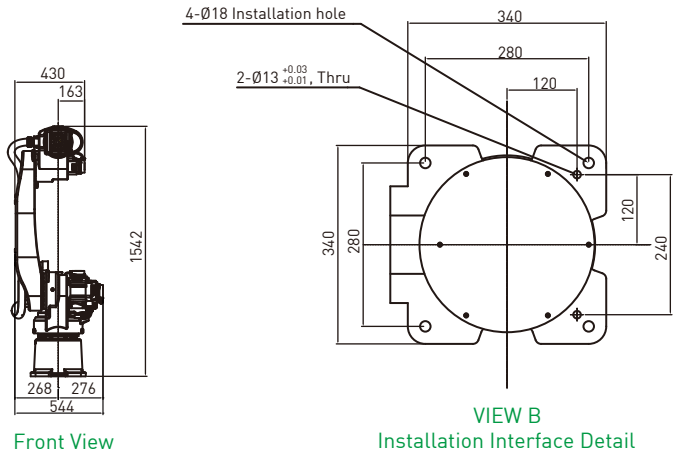
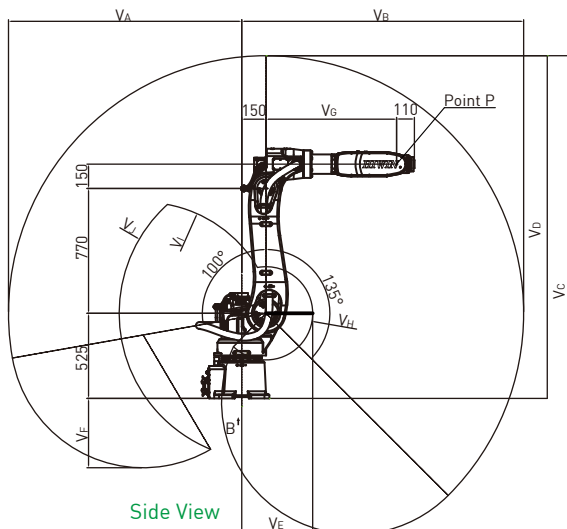
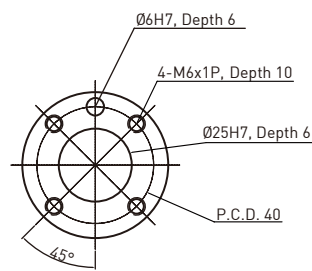
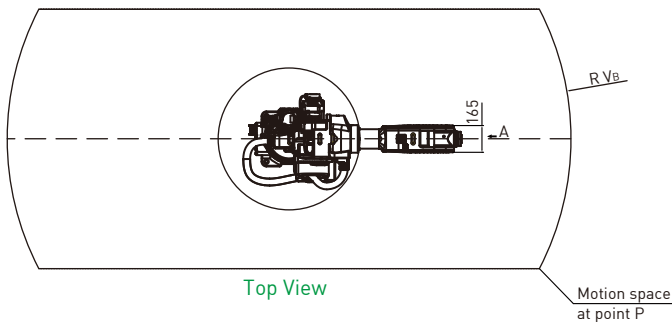

Delta Robot RD403



RD403-1100-FS **CE** **RoHS**

Features

- By utilizing a parallel linkage mechanism, the RD403 can execute high speed motion in a larger work area, with motion stability, short cycle times, high accuracy, high load capacity.
- Integrated with conveyor tracking and a vision positioning system, the RD403 achieves efficient, high-speed, in-line sorting, picking and placing.
- With IP65 certification, the RD403 can be used for automation applications in industries that have requirements for health and safety compliance.
- The RD403-1100-FS design complies with EN1672-2 requirements for food safety and can be used in food industry automation.

Application

- Packaging, arranging, assembly, picking, stacking and inspection.

Model	RD403-1100-FS	RD403-1100-PR-GB
Degrees of freedom		4
Rated payload[kg]		3
Max. working diameter [mm]		1100
Max. working height [mm]		300
Repeatability[mm]		±0.1
Cycle time[s]*Note 1		0.3
Weight[kg]		95
Protection rating		IP65
Controller	RCD403-GB	
Food processing machinery Safety/Environmental Standard	EN1672-2	-
	RoHS	CE/RoHS

* Note 1: Based on a back-and-forth movement over a vertical distance of 25mm and a horizontal distance of 300mm.

Dimensions

Model / Dimensions	V _A	V _B
RD403-1100-FS	31.9	23.9
RD403-1100-PR-GB	39.5	31.5

Unit:mm

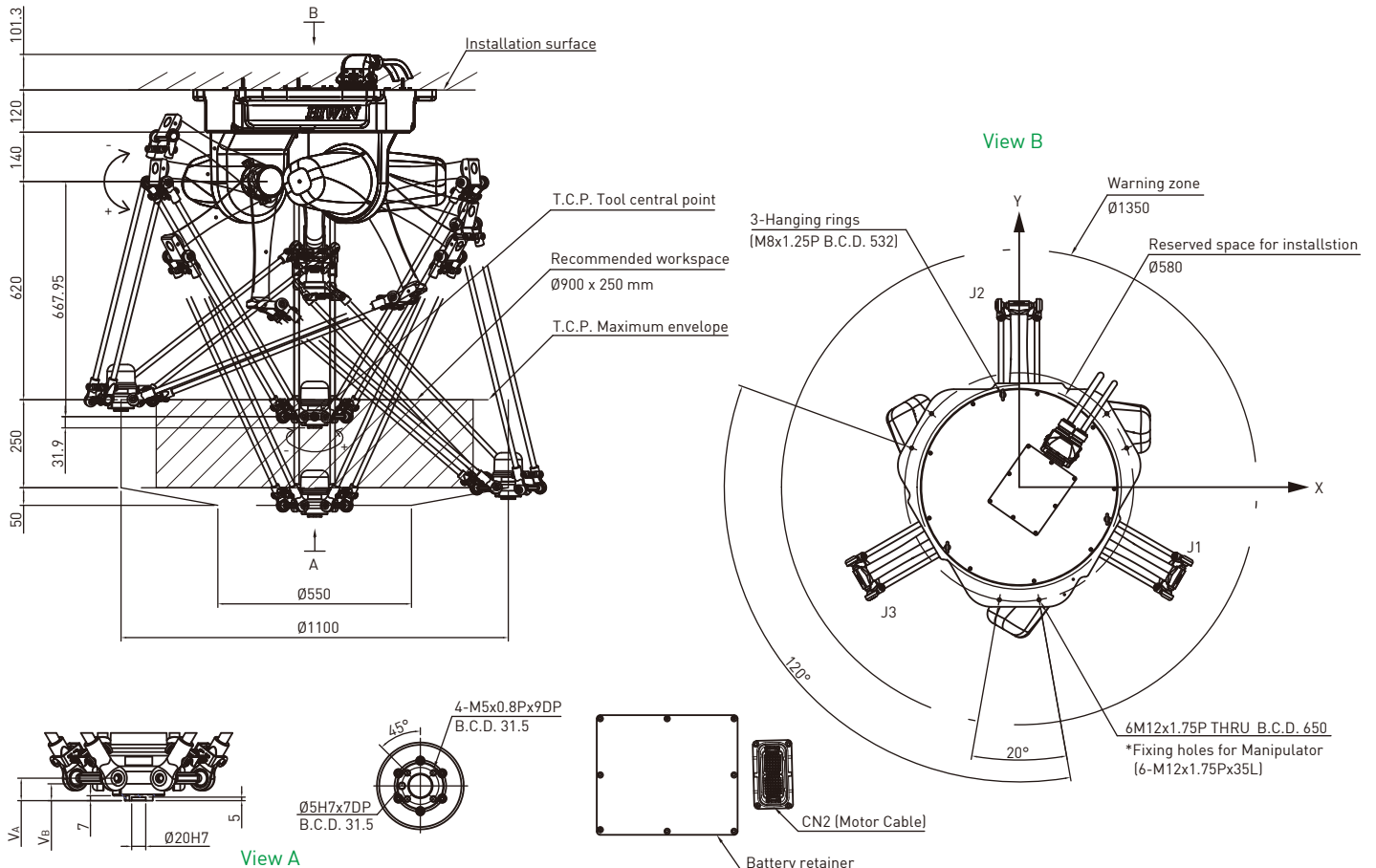

SCARA Robot

RS405

RS410



RS405 Standard



RS410 Protection



Features

- High precision and high flexibility SCARA robot is widely used in various automation field, it can be easily integrated with peripheral control units and combined with linear modules, vision system, end effector etc. In addition to stand alone operations, it can also be used in a system workstation, can easily adapt to changes in production line and enhance quality and efficiency.

Application

- Material handling, arranging, packaging, assembly, dispensing, plugin, inspection.

Model		RS405-LU		RS410-LU		
Degrees of freedom		4				
Rated/Max. payload [kg]		2/5		5/10		
Max. working radius [mm]		400	500	600	700	800
Working range	J1[deg]	±130				
	J2[deg]	±130		±150		
	J3[mm]	200/400				
	J4[deg]	±360				
Cycle time[s]*Note 1		0.42		0.52		
Repeatability	J1-J2[mm]	±0.01	±0.02	±0.02	±0.02	±0.025
	J3[mm]	±0.01				
	J4[deg]	±0.01				
Pneumatic joint [mm]		Ø6x2, Ø4x1		Ø6x3		
Weight[kg]		22	23	30	31	32
Protection rating		IP20/★IP40				
Controller		RC4				
Safety/Environmental Standard		CE/RoHS2.0				
Environment		Standard				

★ Optional * Note 1: Based on a back-and-forth movement over a vertical distance of 25mm and a horizontal distance of 300mm.

Dimensions

Model / Dimensions	V _A	V _B	V _C	V _D	V _E	V _F	V _G	V _H	V _I	V _J	V _K	V _L
RS405-400-200(20P)-LU	602	225	175	410(456.5)	200	150(125)	720	R225	R400	R452	130°	R175.1
RS405-400-400(40P)-LU				610(655)	400							R251.3
RS405-500-200(20P)-LU	702	325		410(456.5)	200	148(123)		R325	R500	R552		
RS405-500-400(40P)-LU				610(655)	400							R251.3
RS410-600-200(20P)-LU	816	325	275	410(461)	200	167(142)	780	R325	R600	R666	150°	R162.7
RS410-600-400(40P)-LU				610(661)	400							R232
RS410-700-200(20P)-LU	916	425		410(459)	200			R425	R700	R766		
RS410-700-400(40P)-LU				610(659)	400							R318.1
RS410-800-200(20P)-LU	1016	525	410(459)	200	R525	R800	R866					
RS410-800-400(40P)-LU			610(659)	400								

Unit:mm

Standard

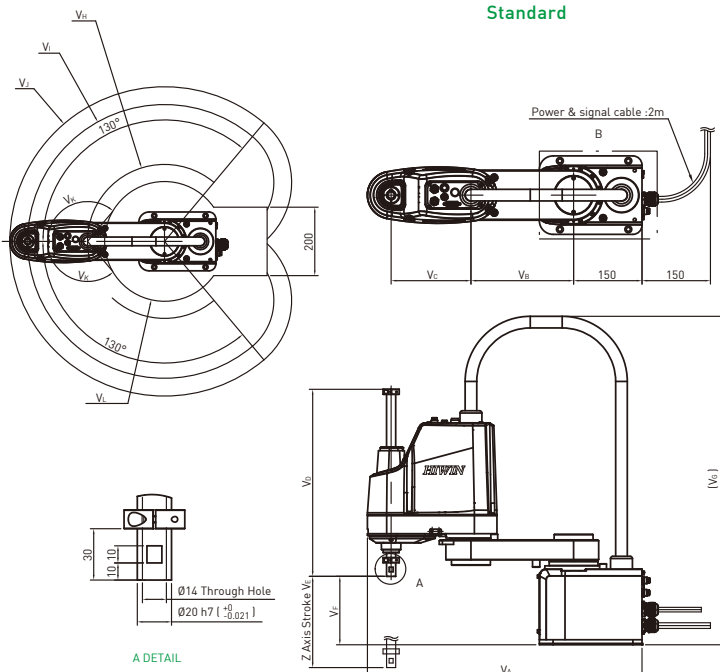

Protection

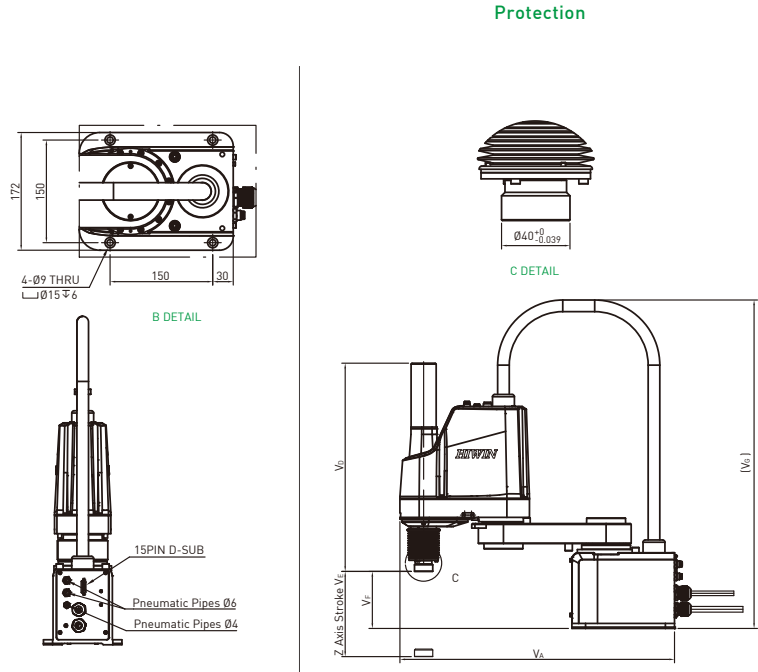

Controller Series



RCA605-GC



RCA620



RCA605-GB



RC4

Dimension

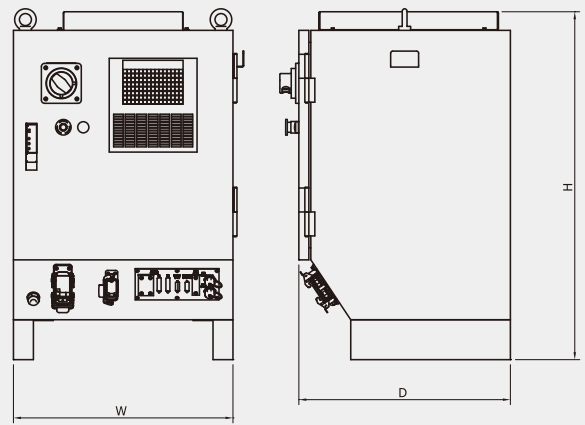

RCA620

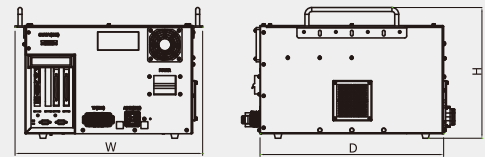

RCA605-GC / RCA610-GC / RCA605-GB

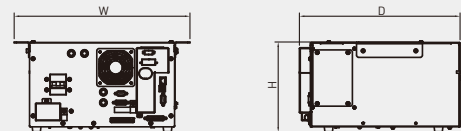

RC4

Specifications

Model		RCA605-GC	RCA610-GC	RCT605-GB	RCA620	RCD403-GB	RC4
Control number of axes		6	6	6	6	4	4
Weight[kg]		29	34	29	80	34	13
Power	Input voltage / frequency	1Ø200-240V 50/60Hz	1Ø200-240V 50/60Hz	1Ø200-240V 50/60Hz	3Ø200-240V *Note 1 50/60Hz	3Ø200-240V *Note 2 50/60Hz	1Ø200-240V 50/60Hz
	Max. current[A]	8A	18A	8A	22A	4.5A	12A
◆ Input/Output *Note 3	Function I/O	8in/8out	8in/8out	8in/8out	8in/8out	8in/8out	8in/8out
	Digital I/O	24in/24out	24in/24out	24in/24out	16in/16out	24in/24out	16in/8out
◆ Communication interface	RS232	✓	✓	✓	-	✓	✓
	RS485 [Modbus-RTU]	✓	✓	-	-	-	✓
	Ethernet	✓	✓	✓	✓	✓	✓
	★ Fieldbus	CC-Link, PROFINET	CC-Link, PROFINET	CC-Link, PROFINET	-	-	CC-Link, PROFINET
	USB	✓	✓	✓	✓	✓	✓
★ Encoder Capture		★	★	★	-	◆ 4ch	★
Ambient temperature [°C]		0~45	0~45	0~45	0~40	0~45	5~45
Ambient humidity [%]		20~75 (Non-condensing)	20~75 (Non-condensing)	20~75 (Non-condensing)	45~85 (Non-condensing)	20~75 (Non-condensing)	20~75 (Non-condensing)
Protection rating		IP23	IP23	IP20	IP54	IP20	IP20 IP23
Dimensions (W x H x D)*Note 4		470 x 328 x 460	470 x 328 x 554	470 x 328 x 460	550 x 872 x 530	470 x 328 x 460	400 x 205 x 366
Safety/Environmental Standard		CE/RoHS2.0	CE/RoHS2.0	-	-	CE/RoHS	★ CE/RoHS2.0

◆ Standard

★ Optional

* Note 1: If the regional power source is 3Ø 380V, an additional transformer(3Ø 380V to 220V, 5KVA) should be applied.

Note 2: If the regional power source is 3Ø 380V, an additional transformer(3Ø 380V to 220V, 2KVA) should be applied.

Note 3: I/O can be expanded, but RCD403-GB is not included.

Note 4: Dimensions needed for cable installation is not included in the drawing.

Global Sales And Customer Service Site

HIWIN GmbH

OFFENBURG, GERMANY
www.hiwin.de
www.hiwin.eu
info@hiwin.de

HIWIN Schweiz GmbH

JONA, SWITZERLAND
www.hiwin.ch
info@hiwin.ch

HIWIN KOREA

SUWON • CHANGWON, KOREA
www.hiwin.kr
info@hiwin.kr

HIWIN JAPAN

KOBE • TOKYO • NAGOYA • NAGANO •
TOHOKU • SHIZUOKA • HOKURIKU •
HIROSHIMA • FUKUOKA • KUMAMOTO,
JAPAN
www.hiwin.co.jp
info@hiwin.co.jp

HIWIN s.r.o.

BRNO, CZECH REPUBLIC
www.hiwin.cz
info@hiwin.cz

HIWIN CHINA

SUZHOU, CHINA
www.hiwin.cn
info@hiwin.cn

HIWIN USA

CHICAGO, U.S.A.
www.hiwin.com
info@hiwin.com

HIWIN FRANCE

STRASBOURG, FRANCE
www.hiwin.fr
info@hiwin.de

Mega-Fabs Motion Systems, Ltd.

HAIFA, ISRAEL
www.mega-fabs.com
info@mega-fabs.com

HIWIN Srl

BRUGHERIO, ITALY
www.hiwin.it
info@hiwin.it

HIWIN SINGAPORE

SINGAPORE
www.hiwin.sg
info@hiwin.sg

HIWIN®

HIWIN TECHNOLOGIES CORP.

No. 7, Jingke Road,
Taichung Precision Machinery Park,
Taichung 40852, Taiwan
Tel: +886-4-23594510
Fax: +886-4-23594420
www.hiwin.tw
business@hiwin.tw

- HIWIN is a registered trademark of HIWIN Technologies Corp. For your protection, avoid buying counterfeit products from unknown sources.
- Actual products may differ from specifications and photos provided in this catalog. These differences may be the result of various factors including product improvements.
- HIWIN website for patented product directory: http://www.hiwin.tw/Products/Products_patents.aspx
- HIWIN will not sell or export products or processes restricted under the "Foreign Trade Act" or related regulations. Export of restricted products should be approved by proper authorities in accordance with relevant laws and shall not be used to manufacture or develop nuclear, biochemical, missiles or other weapons.

The specifications in this catalog are subject to change without notification.

Copyright © HIWIN Technologies Corp.

©2020 FORM C99DE10-2012 (PRINTED IN TAIWAN)