



SCARA Robot RS405-LU / RS410-LU

User Manual

Original Instructions





Multi-Axis Robot

- Pick-and-Place / Assembly / Array and Packaging / Semiconductor / Electro-Optical Industry / Automotive Industry / Food Industry
- Articulated Robot
 - Delta Robot
 - SCARA Robot
 - Wafer Robot
 - Electric Gripper
 - Integrated Electric Gripper
 - Rotary Joint



Single-Axis Robot

- Precision / Semiconductor / Medical / FPD
- KK, SK
 - KS, KA
 - KU, KE, KC



Torque Motor Rotary Table

- Medical / Automotive Industry / Machine Tools / Machinery Industry
- RAB Series
 - RAS Series
 - RCV Series
 - RCH Series



Ballscrew

- Precision Ground / Rolled
- Super S Series
 - Super T Series
 - Mini Roller
 - Ecological & Economical Lubrication Module E2
 - Rotating Nut (R1)
 - Energy-Saving & Thermal-Controlling (Cool Type)
 - Heavy Load Series (RD)
 - Ball Spline



Linear Guideway

- Automation / Semiconductor / Medical
- Ball Type--HG, EG, WE, MG, CG
 - Quiet Type--QH, QE, QW, QR
 - Other--RG, E2, PG, SE, RC



Bearing

- Machine Tools / Robot
- Crossed Roller Bearing
 - Ballscrew Bearing
 - Linear Bearing
 - Support Unit



DATORKER® Robot Reducer

- Robot / Automation Equipment / Semiconductor Equipment / Machine Tools
- WUT-PO Type
 - WUI-CO Type
 - WTI-PH Type
 - WTI-AH Type



AC Servo Motor & Drive

- Semiconductor / Packaging Machine / SMT / Food Industry / LCD
- Drives--D1, D2T/D2T-LM, E1
 - Motors--50W-2000W

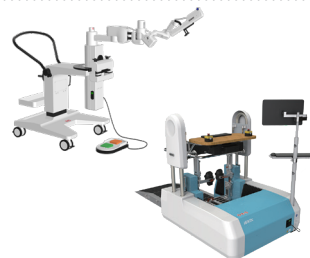

Medical Equipment

- Hospital / Rehabilitation Centers / Nursing Homes
- Robotic Gait Training System
 - Robotic Endoscope Holder

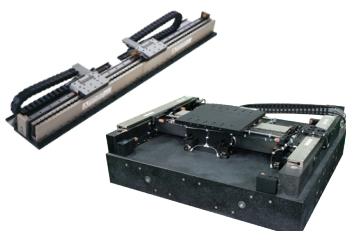

Linear Motor

- Automated Transport / AOI Application / Precision / Semiconductor
- Iron-core Linear Motor
 - Coreless Linear Motor
 - Linear Turbo Motor LMT
 - Planar Servo Motor
 - Air Bearing Platform
 - X-Y Stage
 - Gantry Systems



Torque Motor & Direct Drive Motor

- Machine Tools
- Torque Motor--TM-2/IM-2, TMRW Series
- Inspection / Testing Equipment / Robot
- Direct Drive Motor--DMS, DMY, DMN Series

Warranty Terms and Conditions

The period of warranty shall commence at the received date of HIWIN product (hereafter called “product”) and shall cover a period of 12 months. The warranty does not cover any of the damage and failure resulting from:

1. The damage caused by using with the production line or the peripheral equipment not constructed by HIWIN.
2. Operating method, environment and storage specifications not specifically recommended in the product manual.
3. The damage caused by changing installation place, changing working environment, or improper transfer after being installed by the professional installer.
4. Product or peripheral equipment damaged due to collision or accident caused by improper operation or installation by the unauthorized staff.
5. Installing non-genuine HIWIN products.

The following conditions are not covered by the warranty:

1. Product serial number or date of manufacture (month and year) cannot be verified.
2. Using non-genuine HIWIN products.
3. Adding or removing any components into/out the product without authorized.
4. Any modification of the wiring and the cable of the product.
5. Any modification of the appearance of the product; removal of the components inside the product. e.g., remove the outer cover, product drilling or cutting.
6. Damage caused by any natural disaster. i.e., fire, earthquake, tsunami, lightning, windstorms and floods, tornado, typhoon, hurricane etc.

HIWIN does not provide any warranty or compensation to all the damage caused by above-mentioned circumstances unless the user can prove that the product is defective.

For more information towards warranty terms and conditions, please contact the technical staff or the dealer who you purchased with.

WARNING

- Improper modification or disassemble the robot might reduce the robot function, stability or lifespan.
- The end-effector or the cable for devices should be installed and designed by a professional staff to avoid damaging the robot and robot malfunction.
- Please contact the technical staff for special modification coming from production line set up.
- For the safety reason, any modification for HIWIN product is strictly prohibited.

Safety Precautions

Safety Information

● Safety Responsibility and Effect

1. This chapter explains how to use the robot safely. Be sure to read this chapter carefully before using the robot.
2. The user of the HIWIN industrial robot has responsibility to design and install the safety device meeting the industrial safety regulations in order to ensure personal safety.
3. In compliance with the safety information on industrial robot described in this manual can't guarantee that *HIWIN* robot will not occur any safety problems.
4. This machine is defined as a partly completed machinery, the associated hazards must be handled by system integrator in accordance with ISO 10218-1/ ISO 10218-2.
5. A safety-related part of control system (SRP/CS) should conform to the requirement of performance level (PL)= d and category 3 according to ISO 13849-1.
6. The installation for emergency functions shall be defined by the system integrator in accordance with ISO 10218-1/ ISO 10218-2.

● Safety Operation Principle

1. Before connecting the power supply for HIWIN industrial robot startup assembly procedure, check whether the specification of factory output voltage matches the specification of input voltage of the product. If it does not match, ensure to use the corresponding transformer (HIWIN optional transformer is recommended).
2. Emergency Stop button (on Teach Pendant or from external emergency stop switch) must be pressed before turning off the power, and then switch off the power switch.
3. While connecting to the external I/O or the signal, please operate in the condition that the power switch is turned off to prevent from a shortcut caused by mistaken touch in the process, and resulting in damage.

Safety Precautions

i.General

All personnel involved in the use or setup of the industrial robot arm must read the safety related literature for the robot arm and instruction manual in detail and operate it in accordance with the specifications.

Safety Symbol

 **DANGER**

- Users must strictly abide by the content description, otherwise it will cause serious casualties.

 **WARNING**

- Users must strictly abide by the content instructions, otherwise it may cause minor injuries or equipment damage.

 **CAUTION**

- ❖ User must strictly abide by the content description, otherwise it may cause poor product performance.

Use Limit

Robotic arm is prohibited for use in the following environments and uses

- Personnel carrying purposes
- Explosive environment
- Environment without safety precautions
- Outdoor environment
- Environment affected by oil, water, dust, etc.

ii.Relevant Personnel

Electrical or mechanical work on industrial robot arms is only permitted by professionals.

WARNING

- All personnel working on industrial robotic arms must read and understand the manual containing the safety section of the system of the robotic arm.

System Integrator

Refers to the person who integrates the industrial robot arm into a set of equipment according to safety regulations and puts it into operation.

The system integrator is responsible for the following tasks:

- Install industrial robot arm.
- Industrial machinery arm related equipment connection work.
- Risk assessment of the overall system.
- Use safe guard devices.
- Confirm that the components used by the safe guard devices are in compliance with regulations.
- Placement, replacement, setup, operation, maintenance and repair work is only permitted for specially trained personnel in accordance with the operating instructions for the components of the industrial robot arm.

User

Users must be professionally trained, have the knowledge and experience in this area, and be familiar with the prescribed standards, and thus be able to make a correct judgment of the work to be performed and identify potential hazards.

Users can be defined into three categories based on operational permissions:

1. Operator

- ◆ System startup and shutdown
- ◆ Power on and off
- ◆ Alarm system status recovery

2. Engineer

- ◆ Operating personnel usage authority
- ◆ Programming and changing
- ◆ Arm teaching operation

3. Expert

- ◆ Engineer usage authority
- ◆ Mechanical arm maintenance work

Operator Safety Precautions

The manner and scale of the work and the possible hazards must be explained to the relevant personnel before work, and relevant training courses must be carried out on a regular basis. In the event of an accident or technical correction, a training course must be re-run.

System Set Up Safety Precautions

The system set up only allows specially trained personnel to perform and work in accordance with the installation, setup, operation and other relevant documents provided by the original manufacturer.

Maintenance Personnel's Precautions

Maintenance should only be carried out by specially trained personnel in accordance with the instructions and operating instructions.

iii. Robotic Arm Working Range Definition

- Working area

The working area of the robot is defined as the area of motion under motion constraints, and the working area must be limited to the minimum required.

- Protective area

Operation must be carried out outside the protected area.

A protected area is an area of the working area that is protected by a safe guard device. Please ensure the protective area includes working area of the robot. A safety-related part of control system (SRP/CS) should conform to the requirement of performance level (PL)= d and category 3 according to ISO 13849-1.

! CAUTION

- ❖ Please ensure the emergency stop switch is in reset status before the robot functions.
- ❖ The external device connected to the emergency stop switch circuit should be dry contact (uncharged) switch. It is forbidden to use a live circuit to connect to the controller emergency stop stop switch circuit.

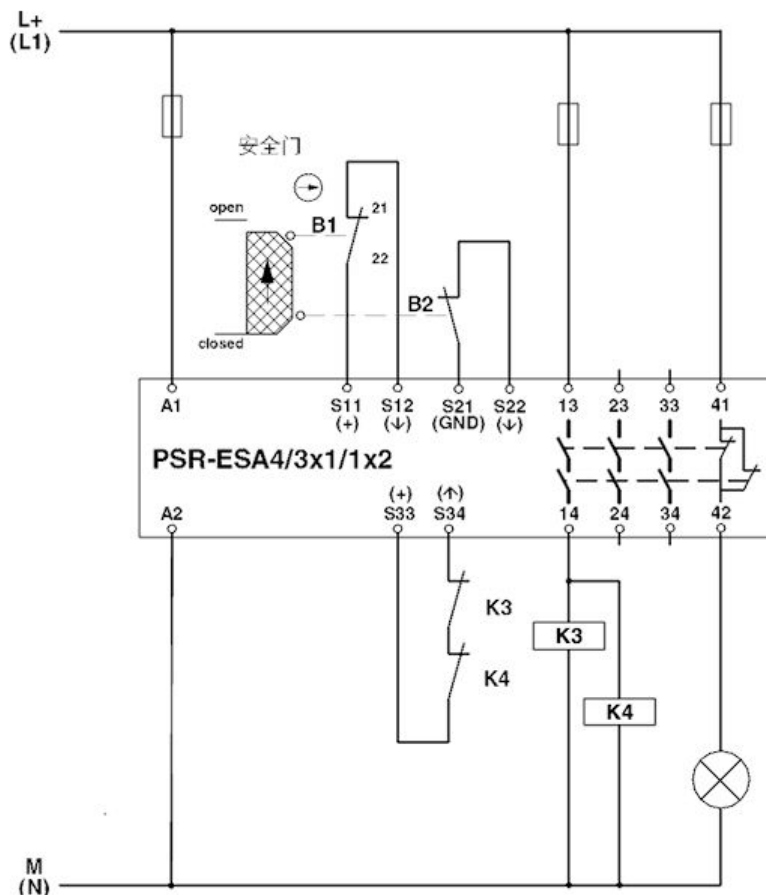

! CAUTION

- ❖ It must use EMO-Emergency stop (EN 60947-5-1 positive opening) with safety module to meet ISO 13849-1 performance level (PL)= d

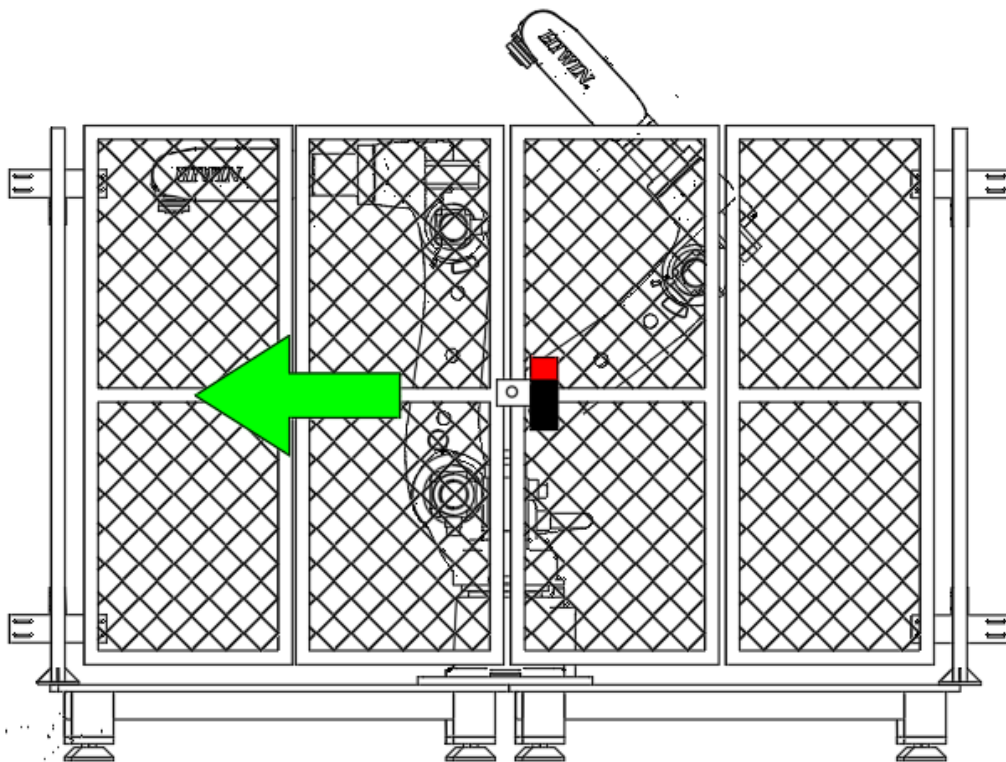

Interlock switch

iv. Description of Safety Functions

Industrial robotic arms must have the following safety features:

- Selection of operating mode of the robot arm
- Safe guard devices
- Emergency stop device

The safety function of the robot arm system is to prevent loss of personnel or property. If the function is not complete or in failure state, the industrial robot arm must be prohibited from operating.

Manual Operation Mode

The manual operation mode is used for program design, program operation check or teaching, etc.

When performing manual operation, pay attention to the followings:

- All actions must be operated within the protection area.
- Do not damage or potentially damage the relevant equipment due to operates the robotic arm.
- **Operation must be carried out outside the protected area.**

Automatic Mode

The automatic mode startup should include the following conditions:

- The safe guard devices have been set up and confirmed that their functions are working properly.
- All suspended security should restore its full functionality.
- Confirm that there are no people in the protected area.
- Relevant workflow rules are complied.

To enter the protection area in this mode, the emergency stop function must be activated before entering.

Safe Guard Devices Description

The safe guard device must use the components approved by the safety regulations and set and plan according to the relevant regulations.

The robotic arm system must be automatically activated to receive the safety signal. In the event of a connection failure during automatic mode operation, an emergency stop must be triggered. When reconnecting after disconnection, the device cannot be automatically started directly and must be started manually. Manual slow running (T1) and manual fast running (T2) modes allow the guard not activate. A method must be provided to confirm that no personnel are in the protected area when the automatic mode is activated.

Users must strictly abide by the content description, otherwise it will cause serious casualties.

Temporary fences can be used during system installation and can be set according to ISO 10218-2 regulations

Stop Functions

Emergency Stop Description

Emergency stop related precautions

- Confirm that the function is functioning normally every six months.
- System integrators should provide emergency stop devices to ensure that the machine is operational or that a hazardous situation exists.
- At least one external emergency stop device is installed. Make sure that additional emergency stop devices are available for use without or losing the teach pendant.
- Provide interface to connect external emergency stop devices.
- The emergency stop function can be triggered when the safety control system connected to the robot arm is cut off.
- The risk assessment should assess whether the emergency stop is not triggered when the robotic arm control system is turned off and provides a response.
- If a tool or other device connected to the robot is dangerous, it must be connected to the emergency stop circuit on the equipment side.

v. Warnings and Precautions

General considerations

DANGER

1. All operating procedures should be assessed by professional and in compliance with related industrial safety regulations.
2. When operating robot, operator needs to wear safety equipment, such as workwear for working environment, safety shoes and helmets.
3. When encountering danger or other emergency or abnormal situation, please press the emergency stop button immediately. After danger is eliminated, move the robot away with low speed in manual mode.
4. When considering safety of the robot, the robot and the system must be considered at the same time. Be sure to install safety fence or other safety equipment and the operator must stand outside the safety fence while operating the robot.
5. A safety zone should be established around the robot with an appropriate safety device to stop the unauthorized personnel from access.
6. While installing or removing mechanical components, be aware of a falling piece which may cause injury to operator.
7. Ensure the weight of workpiece does not exceed the rated load or allowable load moment at wrist. Exceeding these values could lead to the driver alarm or malfunction of the robot.
8. Do not climb on manipulator.
9. Do not store the machine in the environment with corrosion and flammable gas or close to the flammable object.
10. Do not operate the machine in the environment with moisture, water or grease.
11. Do not operate the machine at the place where vibration or the strong impact occurs.
12. Do not immerse the electric wires into grease or water.
13. Do not connect or operate the machine with wet hands.
14. Do not operate the machine in potentially explosive environment.
15. Please ensure the controller is grounded.
16. Keep hands away from the inner part of the controller while it is connecting to the power or during operating.
17. Do not touch the heat sink, regenerative resistance, the power supply or the computer inside the controller while it is operating due to its high temperature.
18. Be sure power is disconnected prior to repair and maintenance, and ensure to operate under the condition of no electrical shock risk.
19. Do not disassembly the controller without permission. If there's any issues, please contact our engineers.

 **WARNING**

1. The personnel installing robot should be trained and licensed.
2. To ensure personal safety, robot installation must comply with this manual and related industrial safety regulations.
3. The control cabinet should not be placed near high voltage or machines that generate electromagnetic fields to prevent interference that could cause the robot to deviation or malfunction.
4. Using non-HIWIN spare parts to repair may cause robot damage or malfunction.
5. Beware of the heat generated by the controller and servo motor.
6. Do not overbend the cable to avoid poor circuit contact or unexpected damage.
7. Do not stand on the controller or put heavy objects on it.
8. Do not block the vent or put foreign objects into the controller.
9. Please ensure the controller is fixed on the base.
10. Do not pull the connector violently or twist the electric wires excessively.
11. Do not frequently switch ON/OFF the power switch and the control button.
12. Please ensure that the robot, the emergency stop switch and the controller are functioning properly before performing any work.
13. Do not shutdown the power switch during the operation.
14. Do not open, modify, disassemble and maintain the machine without permission.
15. The power must be disconnected when the machine does not operate in a long time.
16. Do not turn off the power of the controller when modifying the program or parameter. Otherwise, the data stored in the controller will be damaged.
17. When changing the program or parameters inside the robot controller, do not turn off the power of the controller. Otherwise, the internal data of the controller will be damaged.
18. After the brake of a servo motor is released, the robot will be moved due to gravity and it may injured the operator.
19. The industrial robots can be applied for the different industrial environments, but the applicable environment should be determined by professionals.
20. When the operating procedures are interrupted, the special attention should be paid during the troubleshooting.

Precautions during operations

DANGER

1. Teaching, jogging or programming should be done outside of the safety fence. If it is inevitable to enter the safety fence, press the emergency stop button before entrance. Operation should be restricted at low speed and beware of surrounding safety.
2. All operations shall be executed by trained staff.
3. All operations are required to perform in the safe area.

Maintenance Precautions

DANGER

1. Please contact us if the procedure not specified by HIWIN is needed.
2. Please contact us if the replacement of the component not specified by HIWIN is needed.
3. Be sure to carry out regular maintenance, otherwise it will affect the service life of the robot or other unexpected danger.
4. Prior to repair and maintenance, please switch off power supply.
5. Maintenance and repair should be performed by a qualified operator with a complete understanding of the entire system to avoid risk of robot damage and personal injury.
6. When replacing the components, avoid foreign object going into the robot.

Precautions for using End Effector

End effectors can be basically divided into the following two categories:

A. Gripper: Mainly for pick and place operations, such as pneumatic, electric gripper, vacuum suction cup, etc.

B. Tools: Mainly for processing operations, such as welding, cutting, surface treatment, etc.

DANGER

1. More attention must be paid to the design of the end effector to prevent power loss or any other errors that could lead to workpiece falling or damage.
2. The tool-type end effector is usually equipped with high voltage, high temperature and active rotary shaft. Special attention should be paid to the operating safety.
3. The end effector should be mounted firmly on the robot to avoid workpiece fall during operation which may cause personal injury or hazard.

 **WARNING**

1. The end effector may be equipped with its own control unit. During installation, pay attention to installed location. Ensure that the control unit does not interfere with robot operation.
2. The gripper-type end effector should prevent the workpiece from dropping or damaging when the robot experiences a power error or other errors. If potential dangers or abnormal situations exist when using end effector, the associated hazards must be handled by the system integrator in accordance with the related standards.

Precautions for using Hydraulic and Pneumatic

 **DANGER**

1. When using the pneumatic or hydraulic system, the gripped workpiece may fall due to insufficient pressure or gravity.
2. The pneumatic or hydraulic system must be equipped with the relief valve, so that it can be applied in an emergency.

 **WARNING**

1. More attention should be paid to the pressure remained in the pneumatic systems after the power is disconnected.
2. The internal pressure must be released before the pneumatic systems are maintained.
3. More attention should be paid to the pressure in the pneumatic system as it is several times more than the atmosphere pressure.

Emergency Stop Switch Precautions

DANGER

1. The robot or other control component should have at least one device for immediate halt, such as an emergency stop switch.
2. The emergency stop button must be installed in an easily accessible location for quick stop.
3. While executing an emergency stop, power to the servo motor will be cut, and all movements will be stopped. And the control system will be shut down. Emergency stop should be reset if the restoration of operating procedure is wanted.
4. Avoid using emergency stop to replace a normal stop procedure. This could reduce the lifespan of the robot.

WARNING

1. When an emergency stop is performed, the power of the drive is cut off, all operations are stopped, and the control system of the robot arm is turned off.
2. To resume execution, reset the emergency stop switch.
3. Emergency stop is immediate stop: Immediately stop the movement of the robot arm and cut off the power of the drive.
4. The emergency stop switch is for emergency stop only.
5. **HIWIN's industrial robot arm (SCARA-LU series) has an emergency stop switch, it is automatically connected to the controller via a dedicated cable.** If there is a need for other emergency stop switches, the other means of connection can be used to achieve the purpose of emergency stop.
6. Based on the relevant industrial safety regulations, the emergency stop switch needs to be directly connected to the control box of the robot arm through a physical connection line.
7. Additional installed safety equipment must comply with PL=d level.

Content

0. Safety Precautions	17
1. Transportation and Installation	19
1.1. Transportation	19
1.2. Base Mounting Surface.....	21
1.2.1. Base.....	21
1.3. Installation Method	22
1.3.1. Unpacking and Transporting	22
1.3.2. Robot Body Installation.....	22
1.3.3. Power Connection.....	24
1.4. Grounding.....	25
1.5. Installation Environment	26
1.5.1. Operation Environment	26
1.5.2. Operating Environment of Controller	27
1.5.3. Storage Environment	28
1.6. Standard and Optional Equipment	29
1.6.1. RS405-LU	29
1.6.2. RS410-LU	30
2. Basic Specification	31
2.1. Description of Model Name.....	31
2.2. Labels.....	32
2.3. Robot Specifications	34
2.3.1. RS405-LU	34
2.3.2. RS410-LU	36
2.4. Appearance size and range of motion	40
2.4.1. RS405-400-200-LU	42
2.4.2. RS405-400-400-LU	44
2.4.3. RS405-500-200-LU	46
2.4.4. RS405-500-400-LU	48
2.4.5. RS410-600-200-LU	50
2.4.6. RS410-600-400-LU	52
2.4.7. RS410-700-200-LU	54
2.4.8. RS410-700-400-LU	56
2.4.9. RS410-800-200-LU	58
2.4.10. RS410-800-400-LU	60
2.4.11. RS405-400-20P-LU	62
2.4.12. RS405-400-40P-LU	64
2.4.13. RS405-500-20P-LU	66

2.4.14.	RS405-500-40P-LU	68
2.4.15.	RS410-600-20P-LU	70
2.4.16.	RS410-600-40P-LU	72
2.4.17.	RS410-700-20P-LU	74
2.4.18.	RS410-700-40P-LU	76
2.4.19.	RS410-800-20P-LU	78
2.4.20.	RS410-800-40P-LU	80
2.5.	Mechanical shaft hardware limit.....	82
3.	Device Installation	83
3.1.	End effector installation.....	83
3.1.1.	End Flange.....	84
3.2.	Interface.....	85
3.2.1.	Pneumatic interface.....	85
3.2.2.	Signal Interface.....	87
3.2.3.	Equipment installation.....	91
3.3.	Inertia.....	93
3.3.1.	Moment of inertia calculation	93
3.3.2.	End effector extension load	96
4.	Adjustment	97
4.1.	Zero position setting.....	97
5.	Maintenance.....	100
5.1.	Daily Inspection	103
5.2.	Maintenance Item	107
5.2.1.	Battery Replacement	107
5.2.2.	Timing Belt Replacement	108
5.2.3.	Ball Spline Lubricaion	110
5.2.4.	Reducer Lubrication	110
6.	Robot/Controller Requirements form	121
7.	Safety Certification	122

0. Safety Precautions

Emergency Stop

If you feel abnormal during the movement of the robot, press the emergency stop button immediately. When the emergency stop button is pressed, the robot will stop at the shortest distance by the action of the brake and the motor brake.

Do not press the emergency stop switch when the robot is in normal operation. If the emergency stop switch is pressed during the operation, it may cause damage to the peripheral device and internal hardware.

The emergency button is used in an emergency, and the robot program and action are not suspended. If you want to stop the robot in normal use and working path, please follow the instructions in the software manual.

Free Running Distance In Emergency

The robot arm cannot stop immediately after the emergency stop switch is pressed. The free running time/angle/distance of the robot arm are shown below. However remember that the values vary depending on following conditions.

Conditions for Measurement		
	RS405-500-200	RS410-800-400
Accel Setting(%)	100	100
Speed Setting(%)	100	100
Load (kg)	5	10

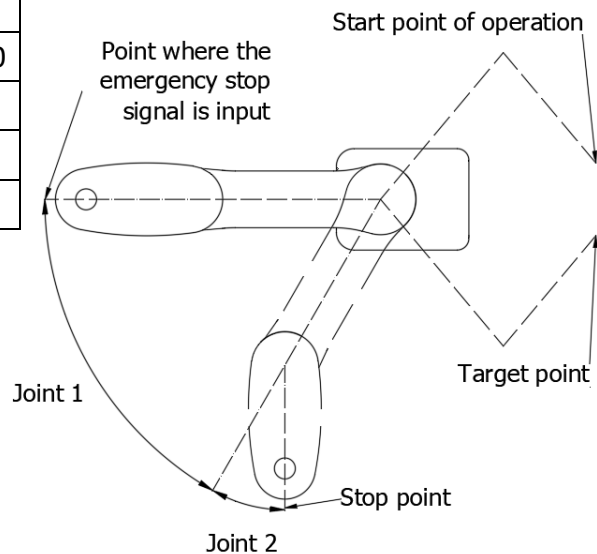

Robot		RS405-500-200	RS410-800-400
Free running time (sec.)	Joint 1 + Joint 2	0.57	0.44
	Joint 3	0.08	0.53
Free running angle (deg.)	Joint 1	119.2	61.2
	Joint 2	25.7	16.6
	Joint 1 + Joint 2	144.9	77.8
Free running distance (mm)	Joint 3	1.3	84.5

Robot Arm Operation Method In An Emergency Stop State

When pressing the emergency stop button, move the robot arm as described below. When performing the above actions, be sure to confirm that the emergency stop button has been pressed and the status indicator is blinking.

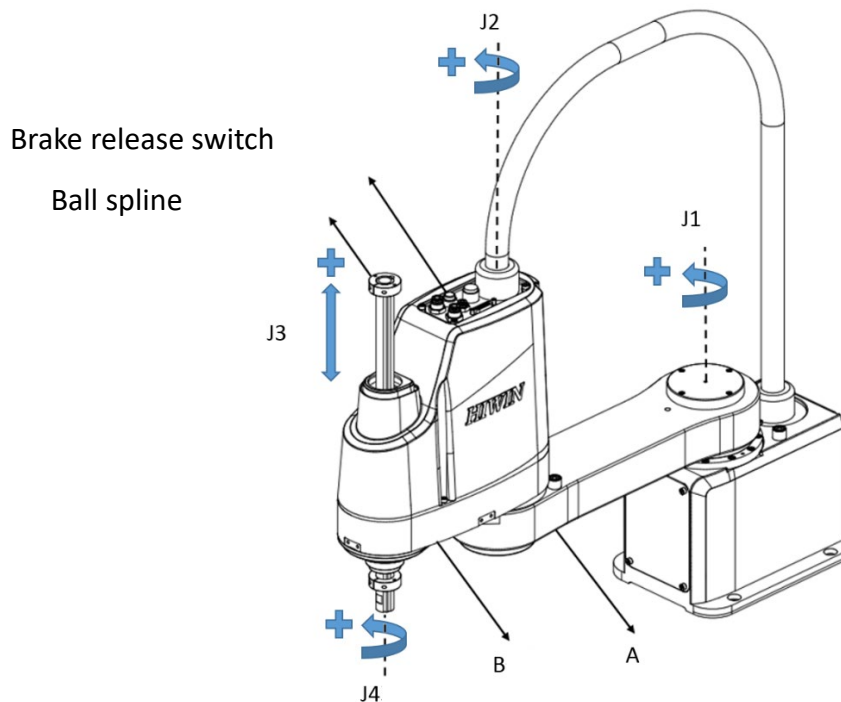

J1 axis: Push the A-arm by hand.

J2 axis: Push the B-arm by hand.

J3 axis: Move the ball spline up/down with your hand.

J4 axis:

(RS405)-Turn/push the ball spline by hand (the ball spline will move up/down at the same time.)

(RS410)-Press and hold the brake release switch, and turn/push the ball spline by hand (the ball spline will move up/down at the same time.)

DANGER

- When pushing the arm manually after pressing the emergency button, do not force the part to rotate too much or quickly. This condition may cause damage to the arm body.
- After pressing the emergency button, press the brake release switch to release the J3 brake. Note that the object attached at the end may fall down due to its own weight and cause casualties.

1. Transportation and Installation

1.1. Transportation

If the weight of the robot arm is greater than 30kg, it must be transported by mechanical means instead of manpower. If the weight is not above the mentioned weight, it can be carried by manpower. It is forbidden for the female and child laborers to carry by hand for less than one year after pregnancy or after delivery. The weight of the robot arm is as follows, and the handling posture is as shown below.

Specification	Robot Weight				
Maximum Reach (mm)	400	500	600	700	800
RS405-LU (kg)	22	23	-	-	-
RS410-LU (kg)	-	-	30	31	32

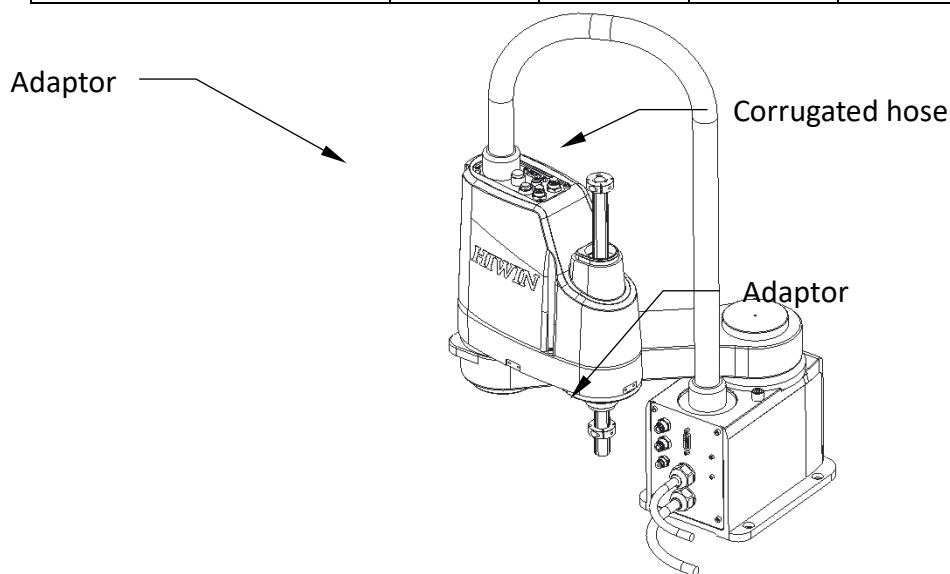

Robot arm transporting posture

WARNING

- Do not pull, squash or bend the corrugated hose and adaptors, which can cause damage to the corrugated hose or internal wiring.

CAUTION

- ❖ The handling of the robot arm should use machinery instead of manpower.
- ❖ It is recommended that two people work together to carry items and reduce the chance of injury.
- ❖ It is recommended to stretch and warm up before starting to move.
- ❖ When carrying the cargo, observe whether there are any obstructions on the path of the return path to avoid falling.
- ❖ When transporting the robot arm, bend it with a bent knee to replace it; do not twist the waist when lifting the robot arm.
- ❖ Avoid maintaining the same posture for a long time. Any static posture is maintained for a period of

time. The muscles in this part are likely to cause fatigue. If the posture is incorrect, it may cause muscle strain.

- ❖ During the process of transporting the robot arm, avoid turning the upper body to rotate the lower body and twisting.

1.2. Base Mounting Surface

When installing the robot arm, use the M8 bolt. Mounting bolt specifications are to be in accordance with ISO 898-1 performance rating: 10.9 or 12.9.

The mounting surface of the base is recommended to have a thickness of 20 mm or more, and is preferably made of steel to reduce vibration during operation. The surface roughness is recommended to be 25 μm or less.

For assembly of other components, please follow the instructions in the operating manual and install them with appropriate tools to avoid injury or machine damage caused by improper operation.

1.2.1. Base

The base of the fixed robot arm is not provided. Customers need to make their own fixed base. The shape and size of the base vary depending on the purpose of the robot. The following robot arm base requirements are for reference.

Force	Specification	RS405-LU	RS410-LU
	Horizontal maximum reaction torque	350 Nm	1000 Nm
	Horizontal maximum reaction force	1500 N	4500 N
	Vertical maximum reaction force	1500 N	2000 N

- ☉ Pass through the external cable on the base. When drilling the hole, please refer to the connector size

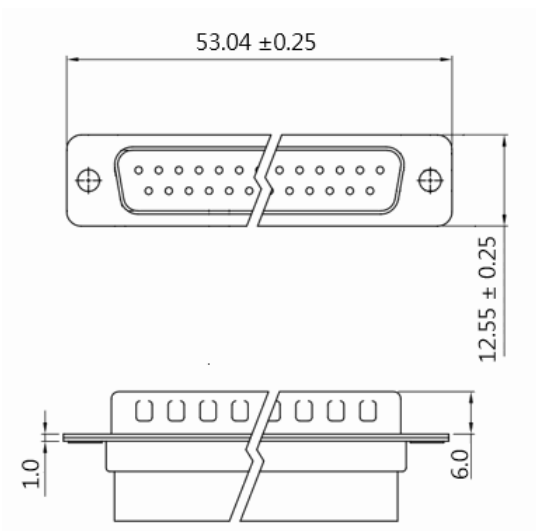

Signal cable connector

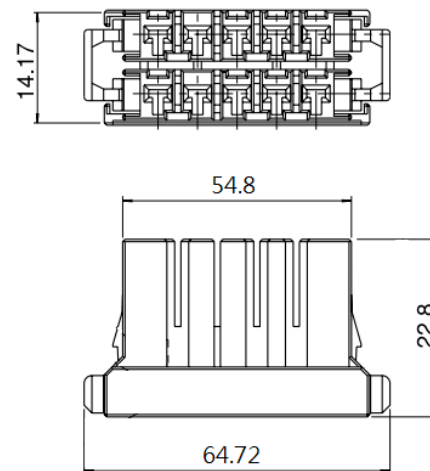

Power cable connector

1.3. Installation Method

1.3.1. Unpacking and Transporting

Please set it by authorized personnel, please be sure to comply with the relevant laws and regulations of each country.

WARNING

- Do not pull, squash or bend the corrugated hose and adaptors, which can cause damage to the corrugated hose or internal wiring.
- Please carry out the transport operations such as hanging by qualified operators. If the operation is carried out by an unqualified operator, it is likely to cause significant injury and is very dangerous.

WARNING

- Please use the trolley to transport the robot arm as much as possible.
- When carrying by hand, two or more operators are required to transport the robot arm, and support the base, A-arm or B-arm and other structural parts with both hands. Do not pull the black wave tube or any joint.
- If the fixing bolts are removed, the robot arm may fall down. Please note that the hand or fingers may be caught by the robot arm.
- When hanging the robot arm, hold it by hand to ensure balance.
- When transporting for long distances, please fix the robot arm directly on the carrying device to prevent it from falling over.
- When transporting the robot, attach it to the carrying device, or hold the shaded part of the figure below (under the base and the A-arm) and carry it by two or more people.

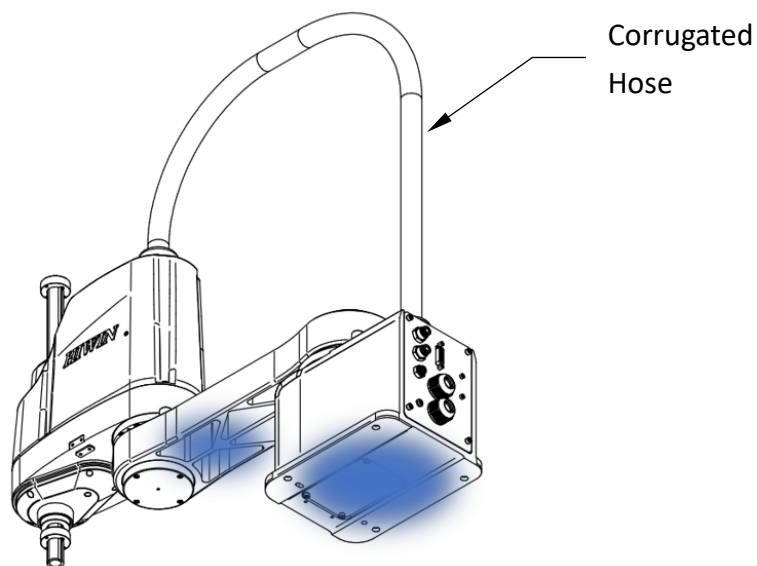

1.3.2. Robot Body Installation

When installing the robot arm, use the M8 bolt. Mounting bolt specifications are to be in accordance with ISO898-1 performance rating: 10.9 or 12.9. The mounting surface of the base is recommended to have a thickness of 20 mm or more, and is preferably made of steel to reduce vibration during operation. The surface roughness is recommended to be 25 μm or less. For assembly of other components, please follow the instructions in the operating manual and install them with appropriate tools to avoid injury or machine damage caused by improper operation.

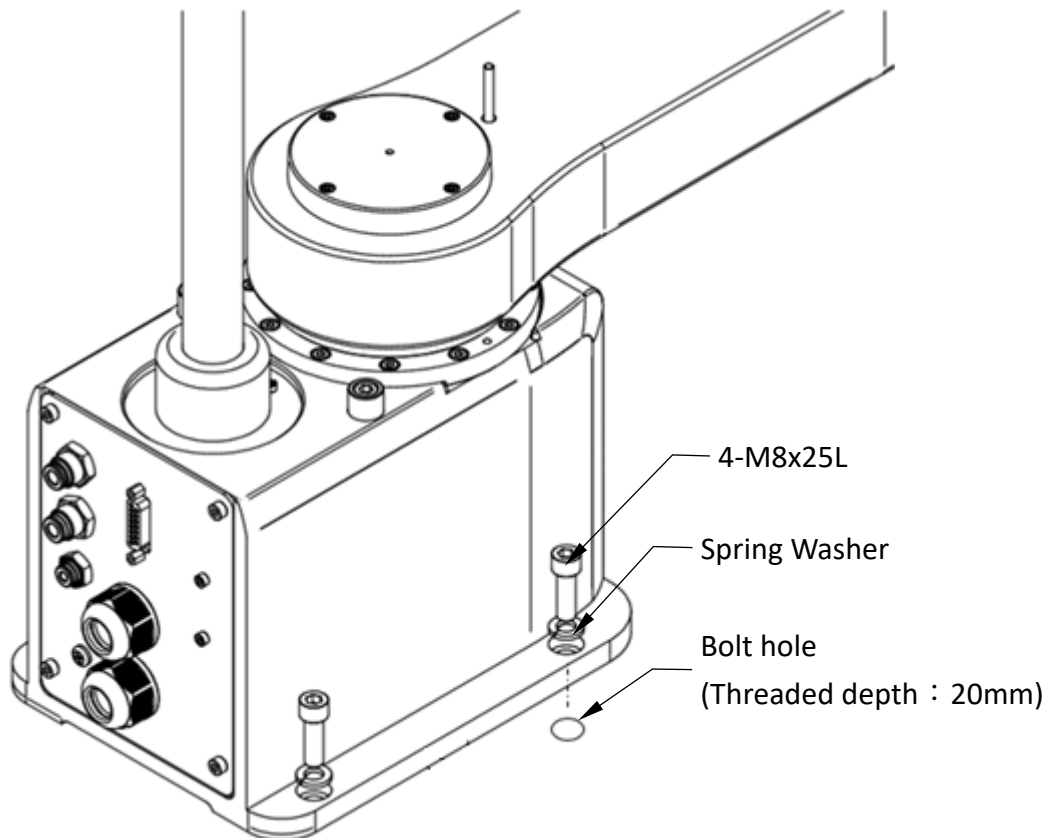

WARNING

- Ensure to install the robot by two or more people.
- The weight of the robot is shown below. Please pay attention to the transporting to avoid personal injury caused by the falling robot.
- When installing the arm, consider the arm actuation range (including the end effector distance) and set the working range warning or safety fence.
- When the arm is activated, it is strictly forbidden to enter to avoid casualties caused by collision of the arm.

1.3.3. Power Connection

WARNING

- When connecting the robot arm to the controller, please make sure that the serial number of each device matches. Improper connection between the robot arm and the controller will not only cause the robot arm system to burn down, but also may cause serious safety problems. The connection method of the robot arm and the controller varies depending on the controller. For details on the connection, refer to the controller manual.

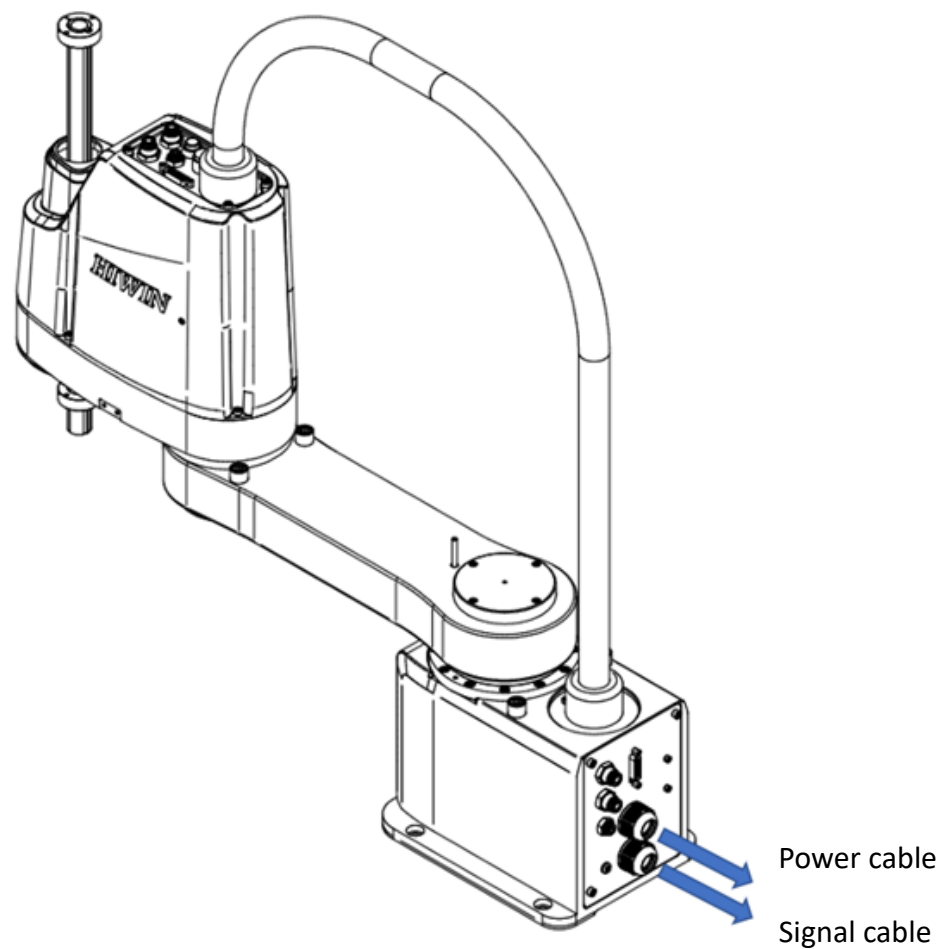

1.4. Grounding

WARNING

- This robot arm must be installed by authorized personnel and in accordance with local regulations. After removing the package and removing the robot arm covered with the protective bag, transport the robot arm to the installation position with appropriate handling aids.
- After the installation and locking is completed, ground the ring terminal (R-type) grounding wire to avoid the risk of electric leakage or electric shock during the operation of the robot arm.

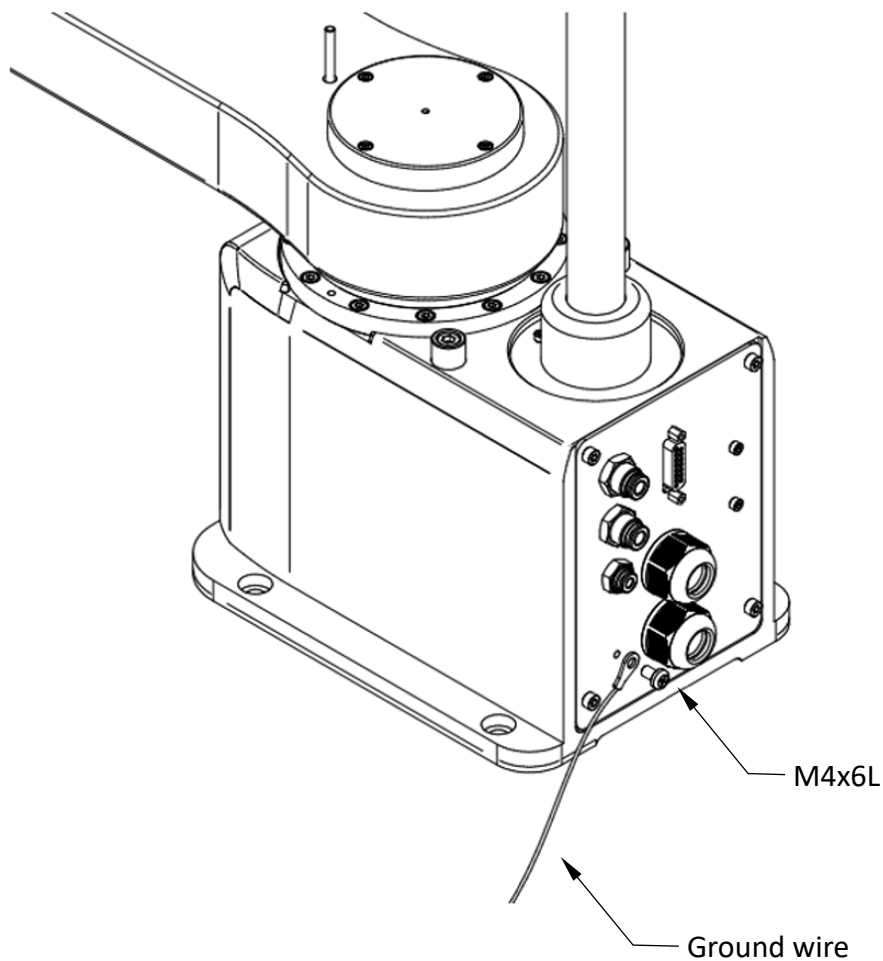

1.5. Installation Environment

1.5.1. Operation Environment

WARNING

- The design of this product is based on the use of indoor environment. If it cannot meet the requirements of the operating environment, it may cause the service life of the product to be shortened or even cause safety problems.
- Before using the robot arm, make sure that the operating environment meets the relevant requirements to maintain the stability and service life of the robot arm.
- RS405-LU robot does not meet the clean room environment, and additional equipment is required to meet the clean room environment.

Environment conditions	Operating environment
Ambient temperature	5°C ~ 45°C [Note 1]
Environment humidity	20%~75% R.H. (No condensation)
Installation method	Upright
Input power	Single phase 50/60Hz 200~240VAC
Allowable height	Altitude 1,000m below [Note 2]
Allow vibration	0.5G(4.9m/s ²) below
other	<ul style="list-style-type: none"> ➤ Do not contaminate flammable or corrosive solvents or gases. ➤ Install indoors to avoid direct sunlight. ➤ Avoid dust, oil mist, salt, metal powder or other contaminants. ➤ Keep away from water and high humidity. ➤ Avoid shock or vibration. ➤ Keep away from sources of electromagnetic interference. ➤ Placement at a higher altitude will result in reduced performance. [Note 2]

[Note 1.] When the arm is stopped for a long time on the rest day, there may be a large resistance when it is ready to run. It is recommended to warm up at a low speed.

[Note 2.] Performance will be reduced by about 10% at altitudes above 1000m.

CAUTION

- ❖ The robot arm is not suitable for use in harsh environments such as coating. If it is necessary to use it in a place that does not meet the above conditions, please contact our company or dealer.
- ❖ The ambient temperature is only applicable to the robot arm.
- ❖ The surface of the robot arm has general oil resistance. If it is possible to contaminate the special oil,

you need to confirm it in advance. Please contact our company or dealer.

- ❖ If the temperature and humidity change greatly, the inside of the robot may condense and cause damage.
- ❖ For use in food-related applications, check the robot arm for food contamination. Contact our company or dealer.
- ❖ Do not use in corrosive environments such as acids and alkalis.
- ❖ Use in environments that are prone to rust such as salt, which may cause rusting of components.

1.5.2. Operating Environment of Controller

WARNING

- The design of this product is based on the use of indoor environment. If it does not meet the requirements of the operating environment, it may cause the product life to be shortened or even cause safety problems.
- Before using the controller, confirm that the operating environment meets the relevant requirements to maintain the stability and service life of the controller.
- RC4 controller does not meet the clean room environment, and additional equipment is required to meet the clean room environment.

Environment conditions	Operating environment
Controller	RC4
Ambient temperature	5°C ~ 45°C [Note1]
Environment humidity	20%~75% R.H. (No condensation)
Installation method	Horizontal 、 Vertical
Input power	Single phase 50/60Hz 200~240VAC
Allowable height	altitude 1,000m below [Note2]
Allow vibration	0.5G(4.9m/s ²) below
other	<ul style="list-style-type: none"> ➤ Do not contaminate flammable or corrosive solvents or gases. ➤ Install indoors to avoid direct sunlight. ➤ Avoid dust, oil mist, salt, metal powder or other contaminants. ➤ Keep away from water and high humidity. ➤ Avoid shock or vibration. ➤ Keep away from sources of electromagnetic interference. ➤ Placement at a higher altitude will result in

	reduced performance.
--	----------------------

 **CAUTION**

- ❖ The controller is not suitable for use in harsh environments such as coating. If it is necessary to use it in a place that does not meet the above conditions, please contact our company or dealer.
- ❖ The ambient temperature is only applicable to the controller.
- ❖ The surface of the controller has general oil resistance. If it is possible to contaminate the special oil, you need to confirm it in advance. Please contact our company or dealer.
- ❖ If the temperature and humidity change greatly, the inside of the controller may be exposed to damage.
- ❖ For food-related occasions, you need to confirm whether the controller has the possibility of causing food contamination. Please contact our company or dealer.
- ❖ Do not use in corrosive environments such as acids and alkalis.
- ❖ Use in environments that are prone to rust such as salt, which may cause rusting of components.

1.5.3. Storage Environment

Please pay attention to the following conditions when storing the arm/controller and store it in the environment shown in the table below to ensure the quality and service life of the arm/controller.

Environment conditions	Storage environment
Storage temperature	5°C ~ 45°C
Storage humidity	20%~75% R.H. (No condensation) [Note1]

[Note 1.] If the robot/controller produces condensation during storage, turn the power on after removing condensation.

1.6. Standard and Optional Equipment

1.6.1. RS405-LU

RS405 Standard and Optional table

Item	Part No.	Qty.	Std.	Optional	Remark
Robot accessory kit	RS405Z031-1	1	●	○	Please refer to the table (RS405)
End flange	RS405Z031-5	1		○	Please refer to the chapter 3.1
Encoder battery	RS405Z031-6	4		○	Please refer to the chapter 5.2.1
Timing belt (J3)	RS405Z031-7	1		○	Please refer to the chapter 5.2.2
Timing belt (J4M)	RS405Z031-8	1		○	Please refer to the chapter 5.2.2
Timing belt (J4S)	RS405Z031-9	1		○	Please refer to the chapter 5.2.2
Ball spline grease 1kg (G04)	RS405Z031-10	1		○	Please refer to the chapter 5.2.3
Reducer grease 16kg (G11)	RS405Z031-11	1		○	Please refer to the chapter 5.2.4

Table(RS405) : Robot accessory kit

Item	Part No.	Quantity	Remark
Calibration tool	RS405Z031-2	1	Please refer to the chapter 4.1
D-Sub Connector (15P)	RS405Z031-3	2	Please refer to the chapter 3.3
D-Sub Connector housing (15P)	RS405Z031-4	2	Please refer to the chapter 3.3

1.6.2. RS410-LU

RS410 Standard and Optional table

Item	Part No.	Qty.	Std.	Optional	Remark
Robot accessory kit	RS410071-1	1	●	○	Please refer to the table (RS410)
End flange	RS410071-5	1		○	Please refer to the chapter 3.1
Encoder battery	RS410071-6	4		○	Please refer to the chapter 5.2.1
Timing belt (J3)	RS410071-7	1		○	Please refer to the chapter 5.2.2
Timing belt (J4M)	RS410071-8	1		○	Please refer to the chapter 5.2.2
Timing belt (J4S)	RS410071-9	1		○	Please refer to the chapter 5.2.2
Ball spline grease 1kg (G04)	RS410071-10	1		○	Please refer to the chapter 5.2.3
Reducer grease 16kg (G11)	RS410071-11	1		○	Please refer to the chapter 5.2.4

Table(RS410) : Robot accessory kit

Item	Part No.	Quantity	Remark
Calibration tool	RS410071-2	1	Please refer to the chapter 4.1
D-Sub Connector (25P)	RS410071-3	2	Please refer to the chapter 3.3
D-Sub Connector housing (25P)	RS410071-4	2	Please refer to the chapter 3.3

2. Basic Specification

2.1. Description of Model Name





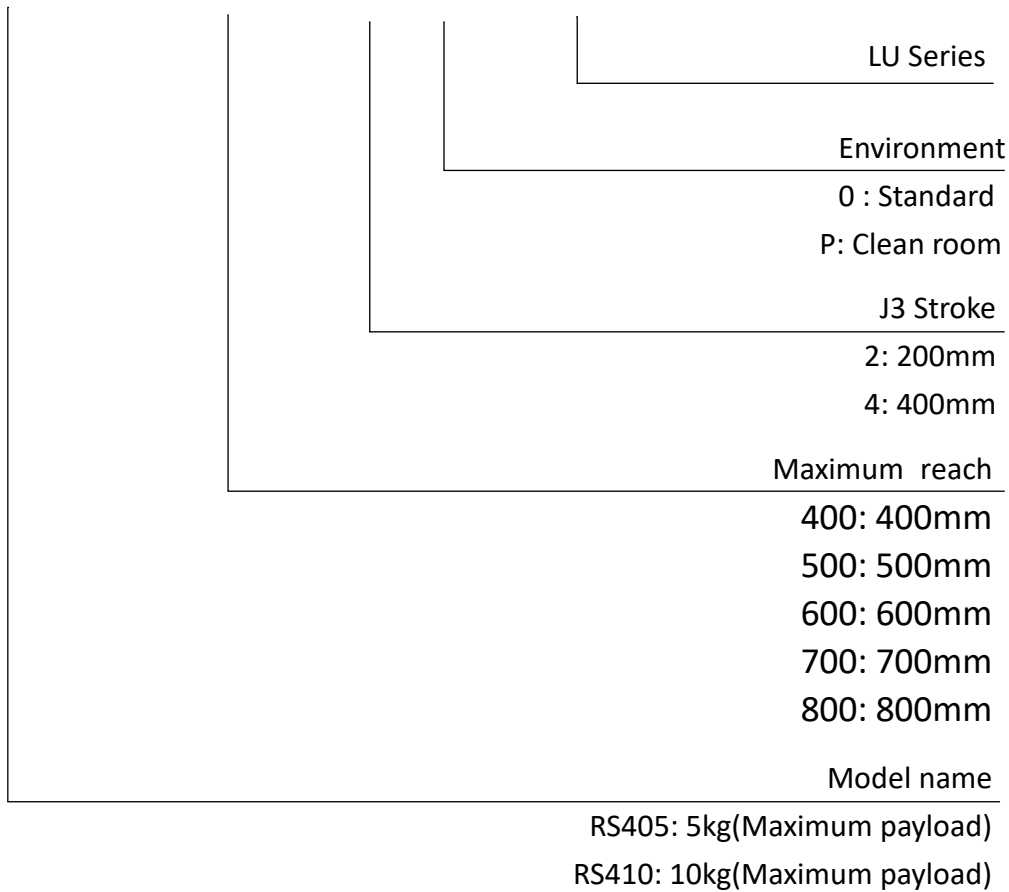

SCARA LU series naming principles and models are shown below.

RS405 – 500 – 200 – LU

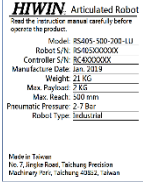
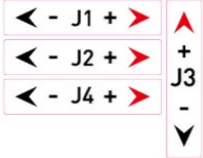

2.2. Labels

Labels description

Sticker Position	Labels	Name	Description
A		<u>Read manual</u>	Read manual before operating the robot.
B		<u>Collision</u>	Keep safety distance from robot system, and prevent colliding to operator during operation.
C		<u>Electric shock</u>	Pay more attention that the robot may have a risk of electric shock.
D		<u>Grip hazard</u>	The robot arm must be kept at a safe distance during operation to avoid pinching.
E		<u>Specification</u>	Robot specification and serial number.
F		<u>Axis label</u>	Axial rotation indication.
G		<u>Grounding</u>	Make sure grounding is completed, or it will cause electric shock.
H		<u>Involved in danger</u>	The robot arm must be kept at a safe distance during operation to avoid getting caught.

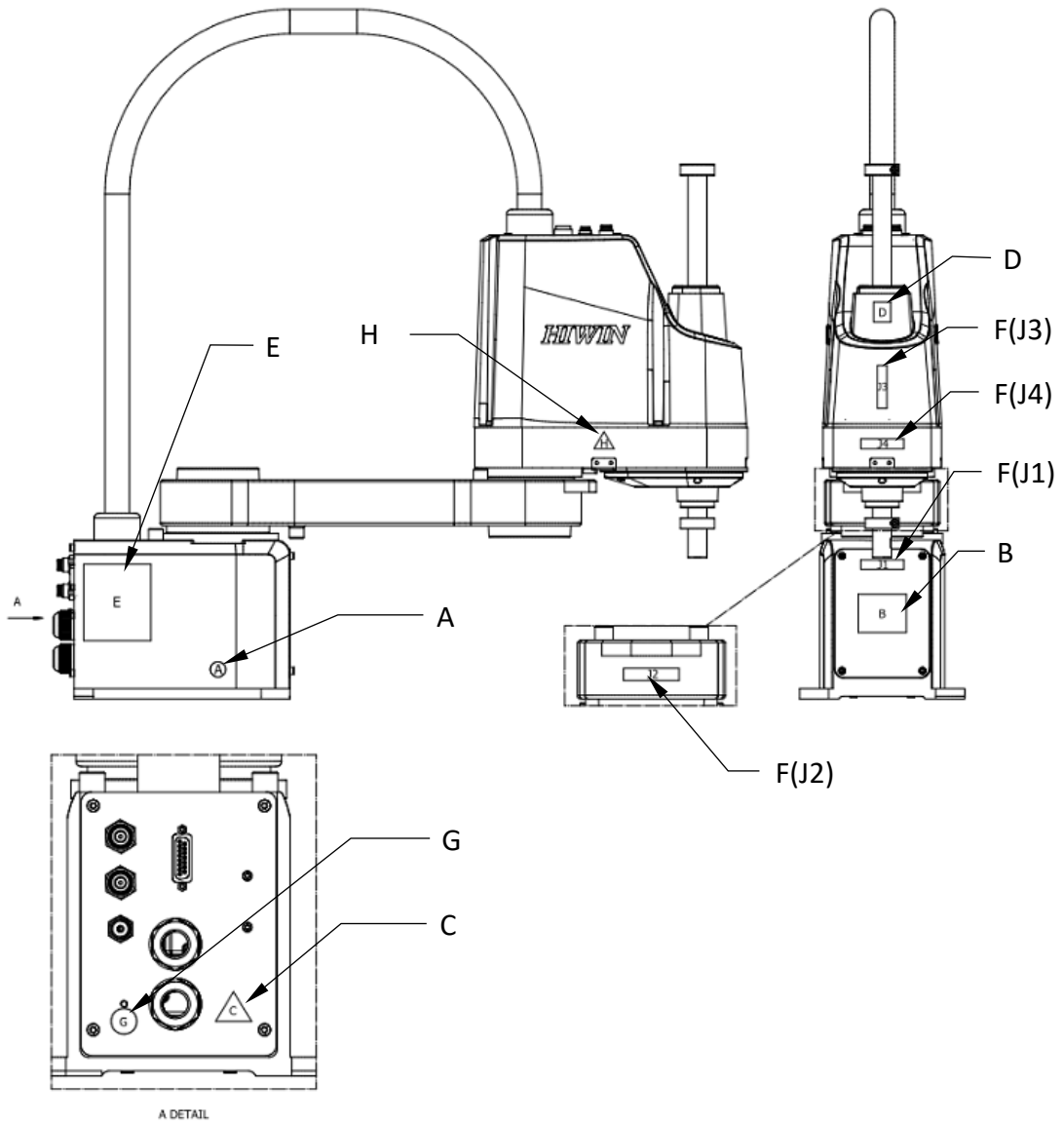

Sticker position description

! CAUTION

- ❖ Do not remove the safety label. If there is any loss, please contact our company or dealer.

2.3. Robot Specifications

2.3.1. RS405-LU

Model Name		RS405-400-2 00(20P)-LU	RS405-400-4 00(40P)-LU	RS405-500-2 00(20P)-LU	RS405-500-4 00(40P)-LU
Degrees of freedom		4			
Installation		Horizontal platform [Note 1]			
Payload	Rated	2 kg			
	Maximum	5 kg			
Cycle time [Note 2]		0.42 s		0.40 s	
Repeatability	J1+J2	±0.01 mm		±0.02 mm	
	J3	±0.01 mm			
	J4	±0.01 °			
Arm length	J1+J2	400 mm		500 mm	
	J1	225 mm		325 mm	
	J2	175 mm		175 mm	
Maximum reach	J1	±130 °			
	J2	±130 °			
	J3 [Note 3]	200 mm	400 mm	200 mm	400 mm
	J4	±360 °			
J4 allowable moment of inertia	Rated	0.01 Kg-m ²			
	Maximum	0.12 Kg-m ²			
Ball spline	Shaft diameter	φ20 mm			
	Through hole	φ14 mm			
Mounting holes	Demension	150 mm * 150 mm			
	Bolt specification	4-M8			
Weight		22 kg		23 kg	
J3 down force		100 N			
Terminal external signal connector		15 pin (D-Sub)			
External air supply		2- φ6 mm (8 Kgf/cm ²)			
		1- φ4 mm (8 Kgf/cm ²)			
Environmental conditions	Ambient temperature	5~45°C			
	Relative	20%~75% below(no condensation)			

	humidity	
Protection level		IP20 (IP40)
Noise level		72 dB
Applicable controller		RC4
Power signal cable [Note 4]		2 m

[Note 1.] The installation of the horizontal platform will result in reduced efficiency of the robot arm.

[Note 2.] The cycle time is the operating time under certain conditions. When the load is 2kg, the arc-shaped reciprocating motion of 25mm vertical and 100mm horizontal is not achieved by any path and load, and it cannot be continuously operated.

[Note 3.] If you have any special needs, please contact HIWIN.

[Note 4.] The power signal cable must have a bend radius of at least 150 mm and is not allowed for use with the drag chain.

2.3.2. RS410-LU

Model Name		RS410-600-2 00(20P)-LU	RS410-600-4 00(40P)-LU	RS410-700-2 00(20P)-LU	RS410-700-4 00(40P)-LU
Degrees of freedom		4			
Installation		Horizontal platform [Note 1]			
Payload	Rated	5 kg			
	Maximum	10 kg			
Cycle time [Note 2]		0.52 s		0.52 s	
Repeatability	J1+J2	±0.02 mm			
	J3	±0.01 mm			
	J4	±0.01 °			
Arm length	J1+J2	600 mm		700 mm	
	J1	325 mm		425 mm	
	J2	275 mm		275 mm	
Maximum reach	J1	±130 °			
	J2	±150 °			
	J3 [Note 3]	200 mm	400 mm	200 mm	400 mm
	J4	±360 °			
J4 allowable moment of inertia	Rated	0.02 Kg-m ²			
	Maximum	0.25 Kg-m ²			
Ball spline	Shaft diameter	φ20 mm			
	Through hole	φ14 mm			
Mounting holes	Demension	150 mm * 150 mm			
	Bolt specification	4-M8			
Weight		30 kg		31 kg	
J3 down force		250 N			
Terminal external signal connector		25 Pin (D-Sub)			
External air supply		3- φ6 mm (8 Kgf/cm ²)			
Environmental conditions	Ambient temperature	5~45°C			
	Relative humidity	20%~75% below (no condensation)			
Protection level		IP20 (IP40)			

Noise level	72 dB
Applicable controller	RC4
Power signal cable [Note 4]	2 m

[Note 1.] The installation of the horizontal platform will result in reduced efficiency of the robot arm.

[Note 2.] The cycle time is the operating time under certain conditions. When the load is 2kg, the arc-shaped reciprocating motion of 25mm vertical and 300mm horizontal is not achieved by any path and load, and it cannot be continuously operated.

[Note 3.] If you have any special needs, please contact HIWIN.

[Note 4.] The power signal cable must have a bend radius of at least 150 mm and is not allowed for use with the drag chain.

Model Name		RS410-800-200(20P)-LU	RS410-800-400(40P)-LU
Degrees of freedom		4	
Installation		Horizontal platform [Note 1]	
Payload	Rated	5 kg	
	Maximum	10 kg	
Cycle time [Note 2]		0.57 s	
Repeatability	J1+J2	±0.025 mm	
	J3	±0.01 mm	
	J4	±0.01 °	
Arm length	J1+J2	800 mm	
	J1	525 mm	
	J2	275 mm	
Maximum reach	J1	±130 °	
	J2	±150 °	
	J3 [Note 3]	200 mm	400 mm
	J4	±360 °	
J4 allowable moment of inertia	Rated	0.02 Kg-m ²	
	Maximum	0.25 Kg-m ²	
Ball spline	Shaft diameter	φ20 mm	
	Through hole	φ14 mm	
Mounting holes	Demension	150 mm * 150 mm	
	Bolt specification	4-M8	
Weight		32 kg	
J3 down force		250 N	
Terminal external signal connector		25 Pin (D-Sub)	
External air supply		3- φ6 mm (8 Kgf/cm ²)	
Environmental conditions	Ambient temperature	5~45°C	
	Relative humidity	20%~75% below (no condensation)	
Protection level		IP20 (IP40)	
Noise level		72 dB	
Applicable controller		RC4	

Power signal cable [Note 4]	2 m
-----------------------------	-----

[Note 5.] The installation of the horizontal platform will result in reduced efficiency of the robot arm.

[Note 6.] The cycle time is the operating time under certain conditions. When the load is 2kg, the arc-shaped reciprocating motion of 25mm vertical and 300mm horizontal is not achieved by any path and load, and it cannot be continuously operated.

[Note 7.] If you have any special needs, please contact HIWIN.

[Note 8.] The power signal cable must have a bend radius of at least 150 mm and is not allowed for use with the drag chain.

2.4. Appearance size and range of motion

☉ RS405-LU Interface

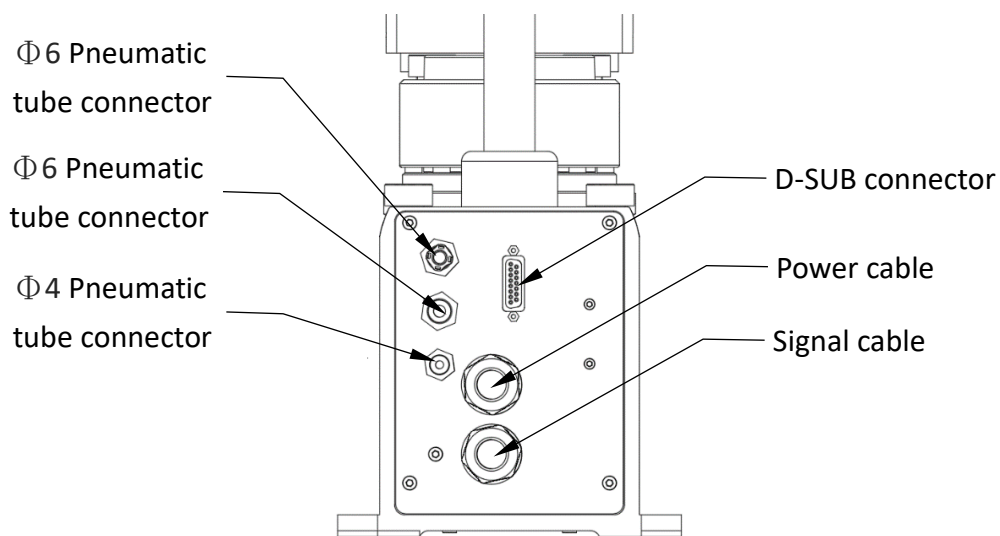
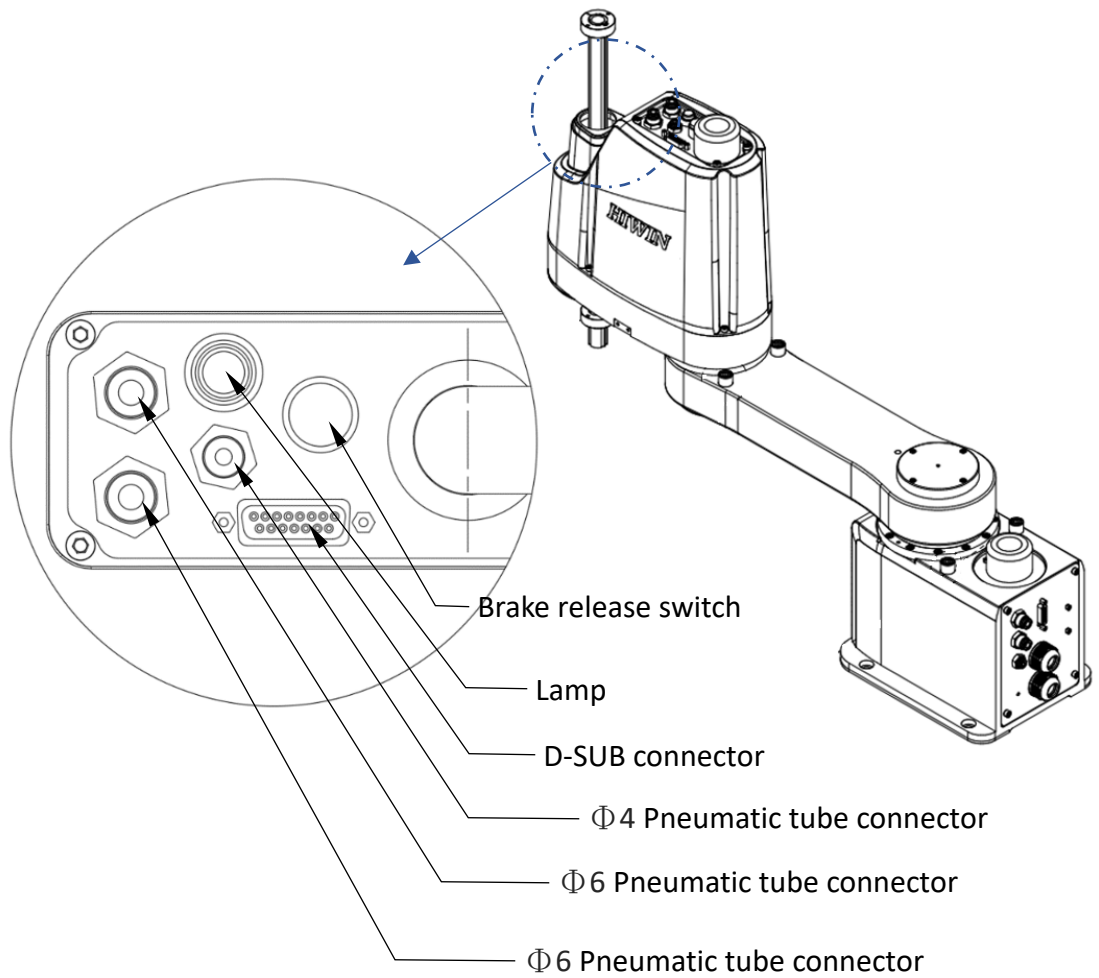

◎ RS410-LU Interface

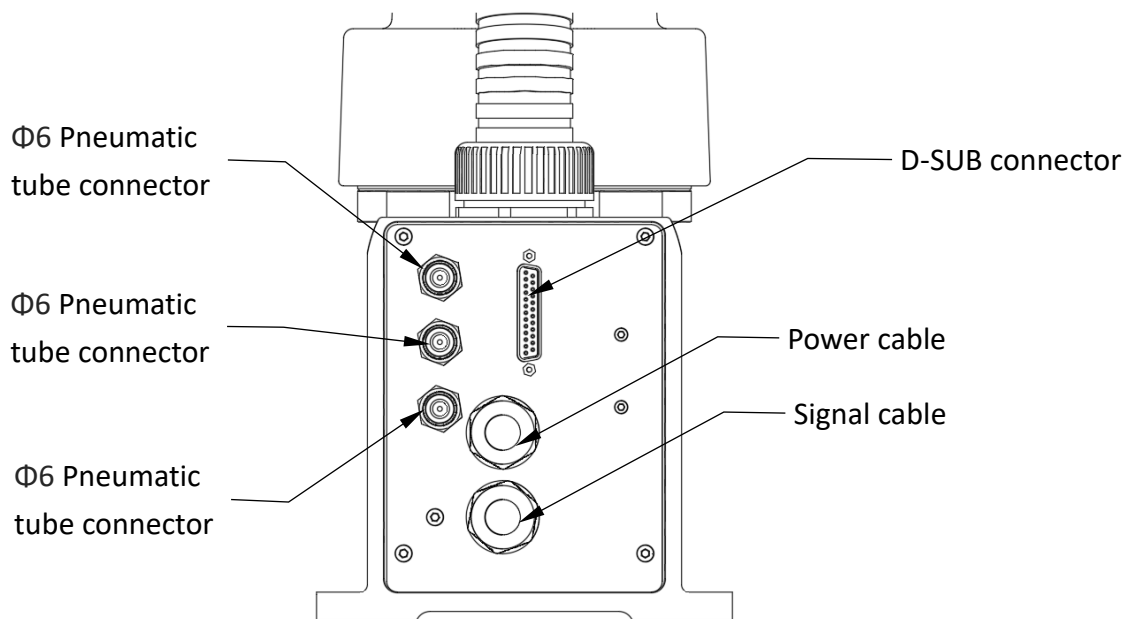
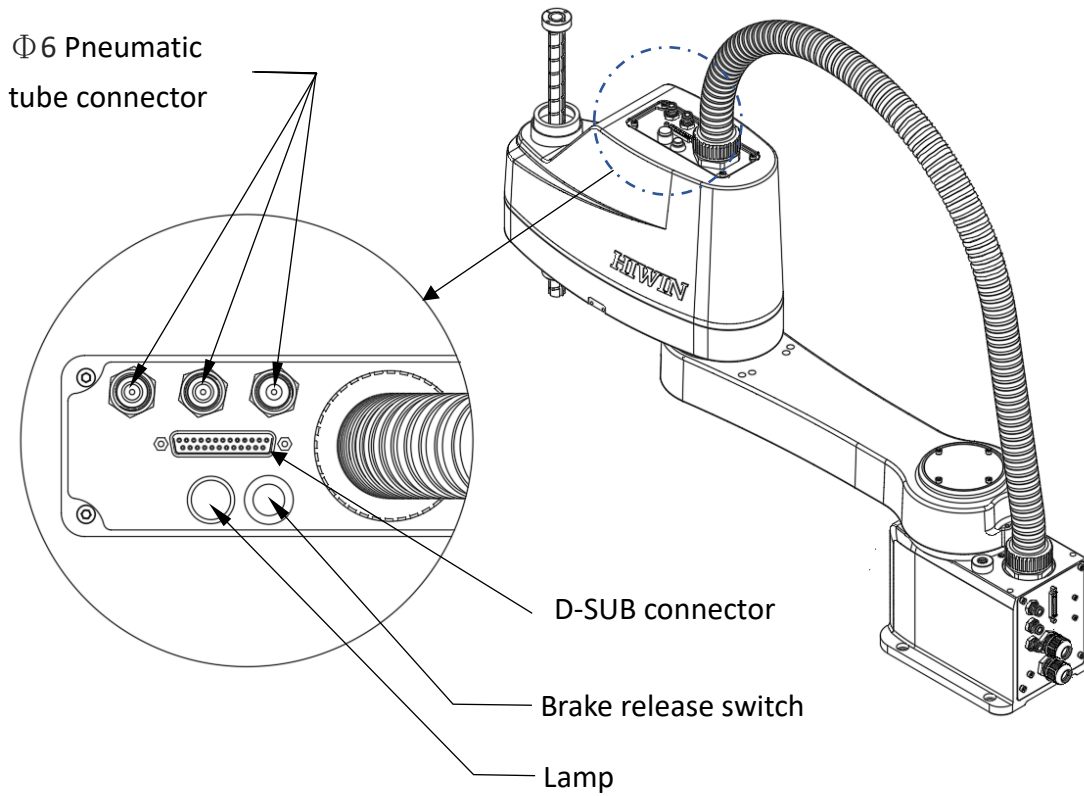

2.4.1. RS405-400-200-LU

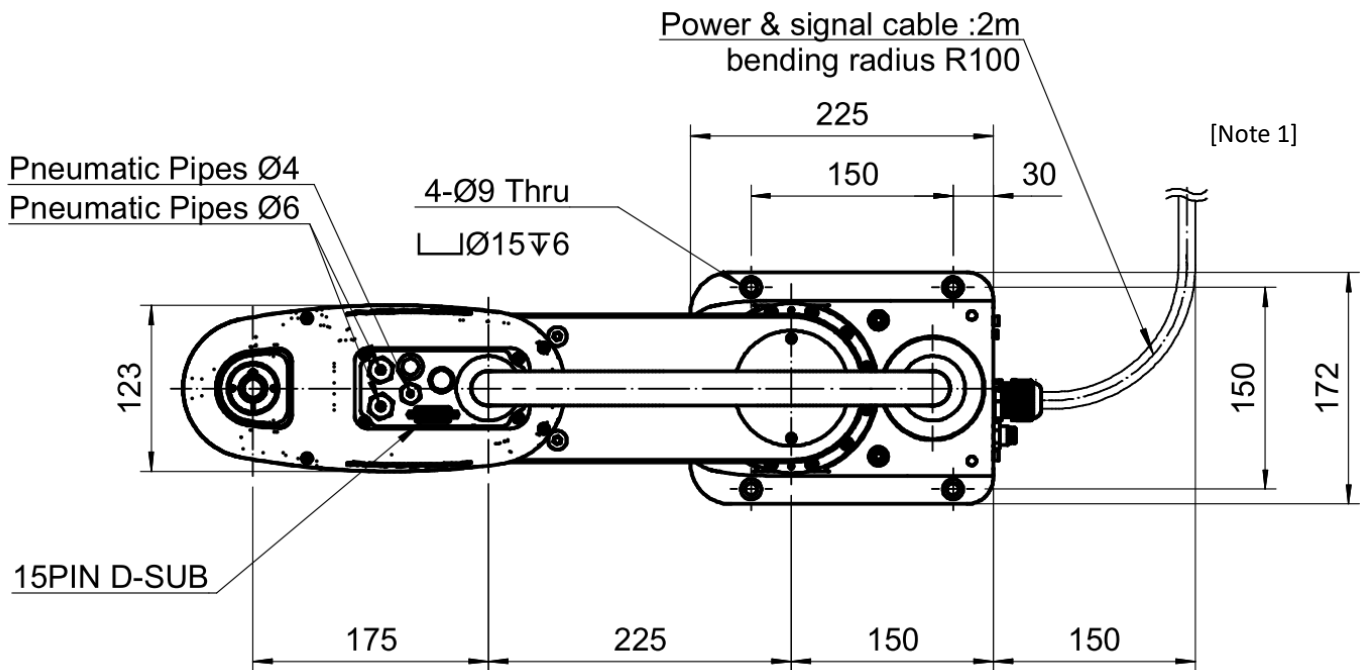

[Note 1] Cable bending radius of at least 150mm, please reserve space to deploy the cable

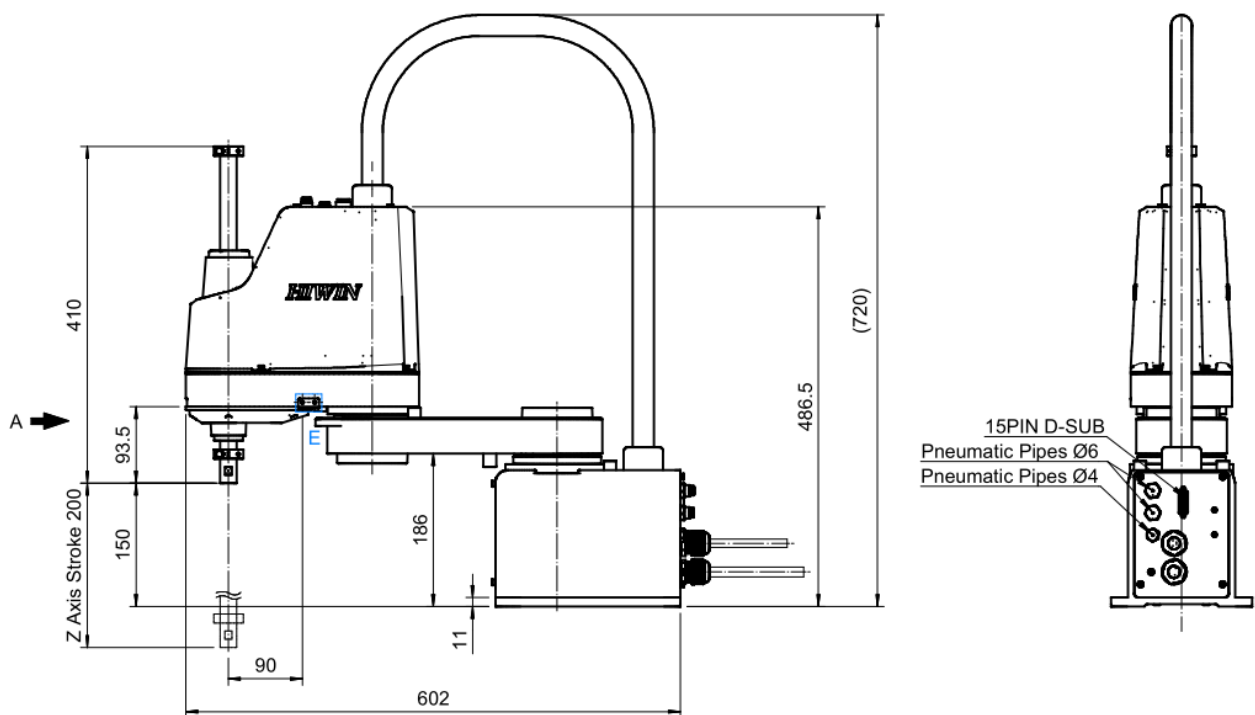

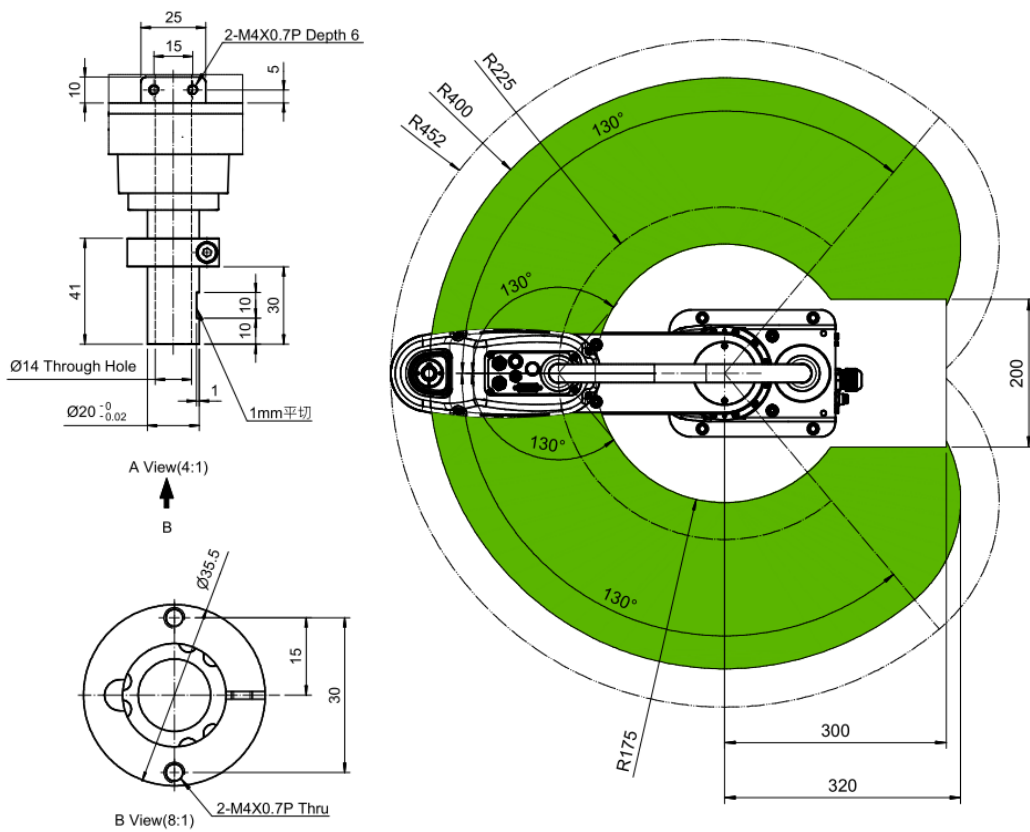
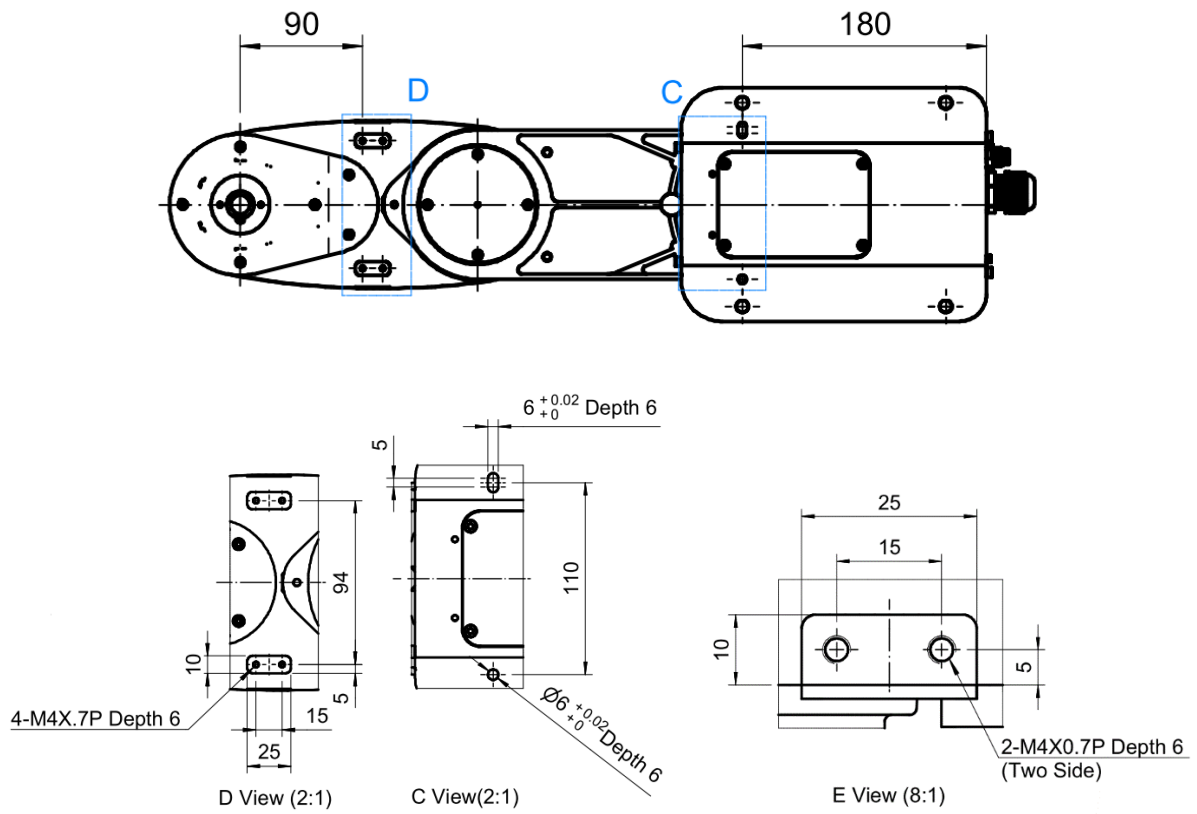

2.4.2. RS405-400-400-LU

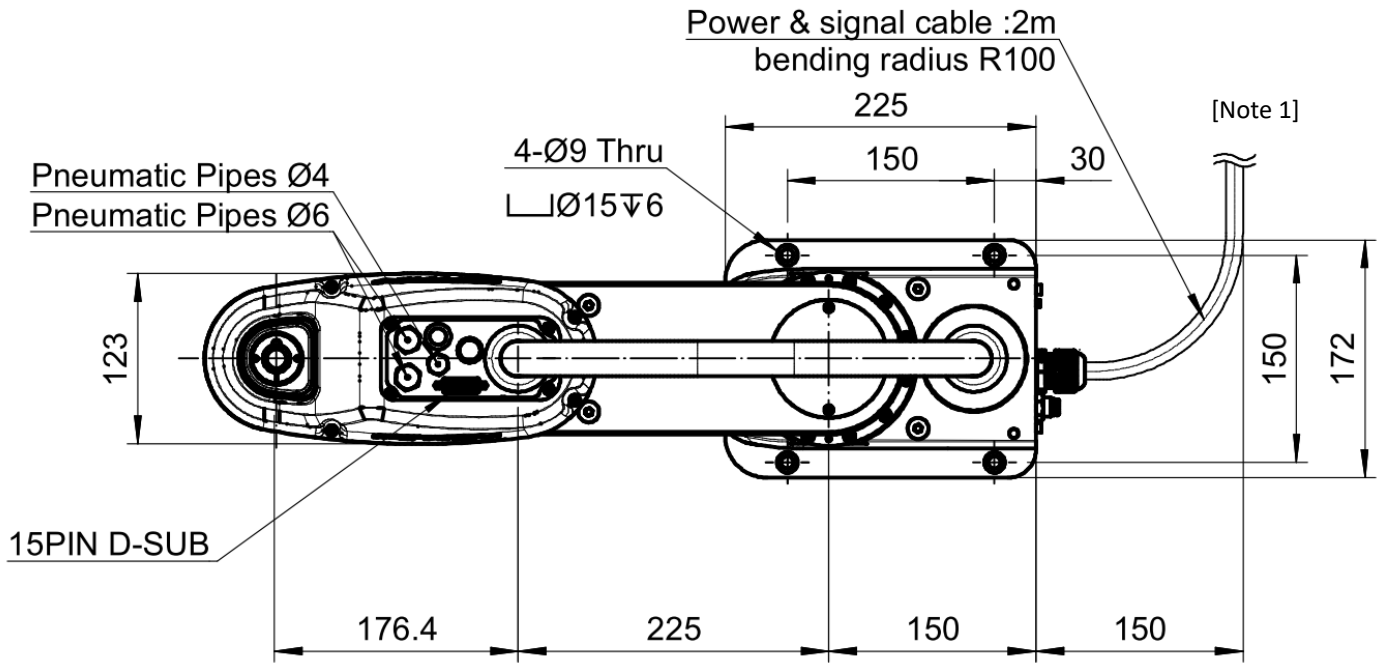

[Note 1] Cable bending radius of at least 150mm, please reserve space to deploy the cable

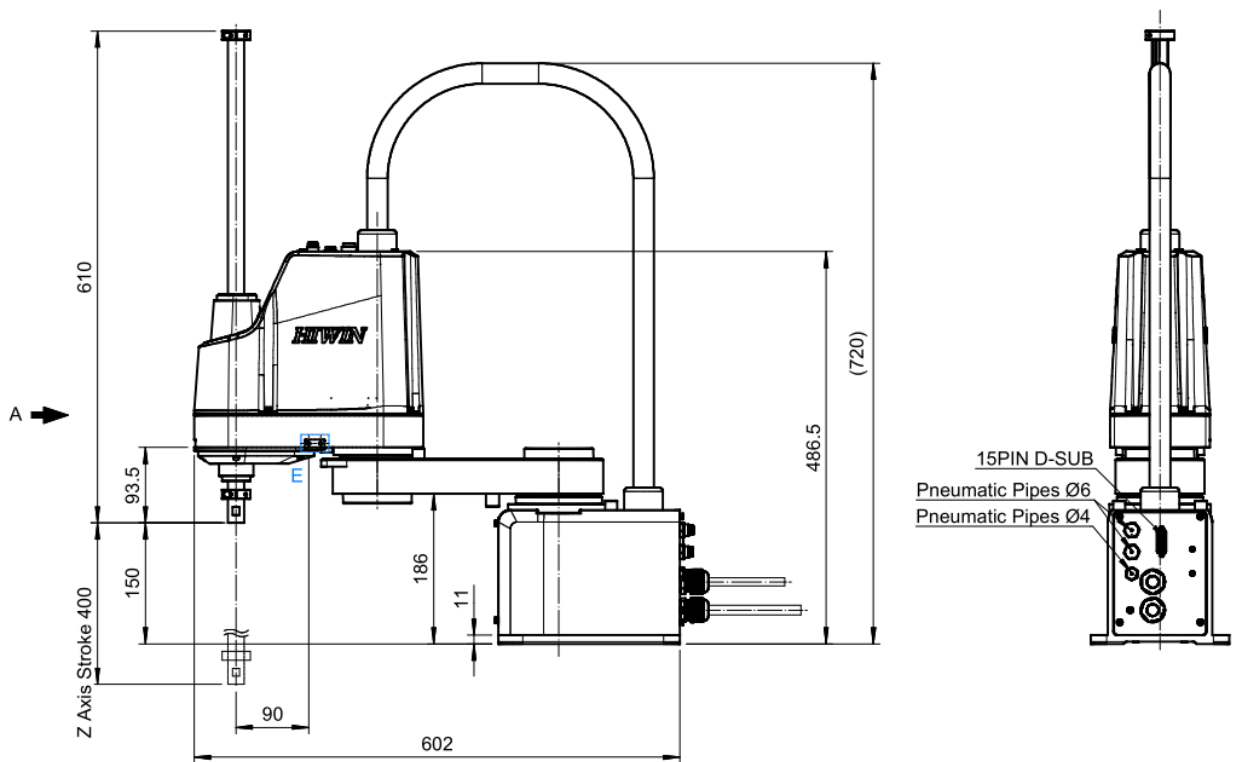

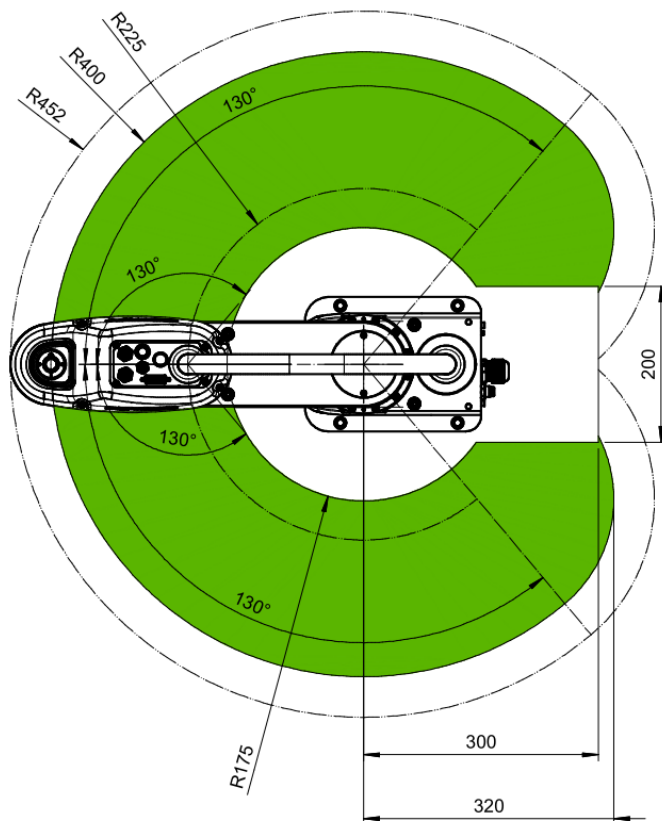
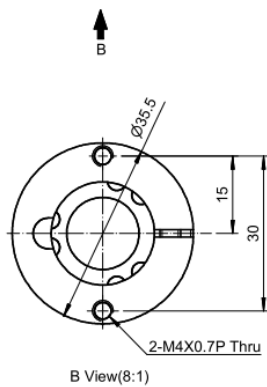
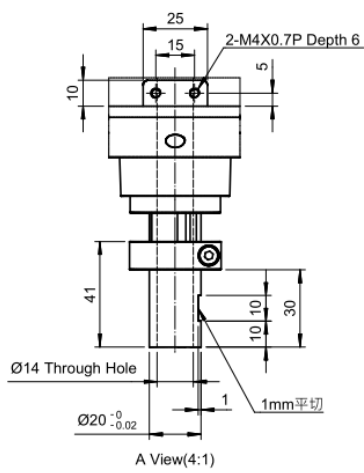
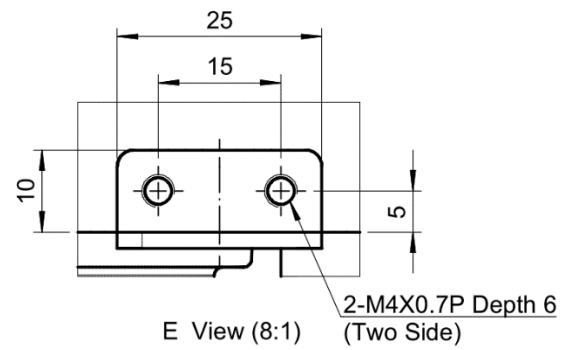
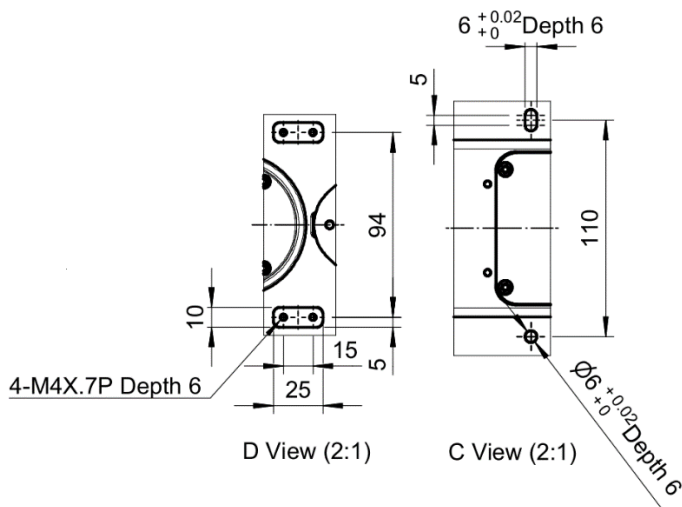
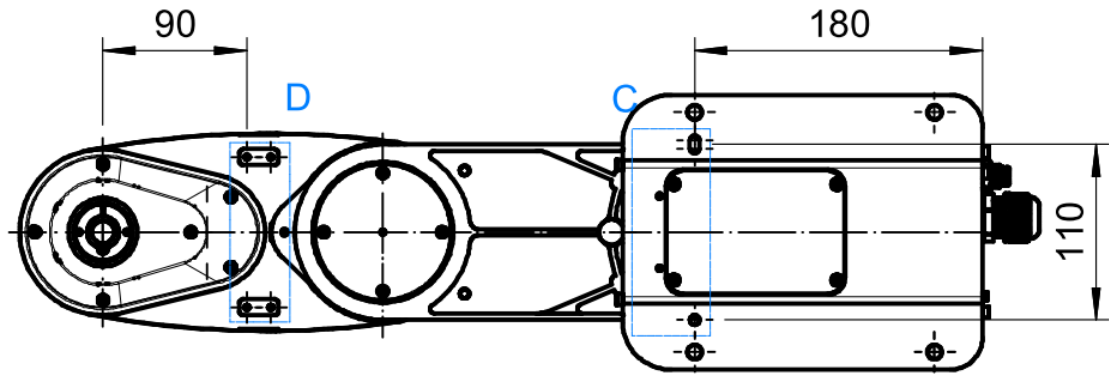

2.4.3. RS405-500-200-LU

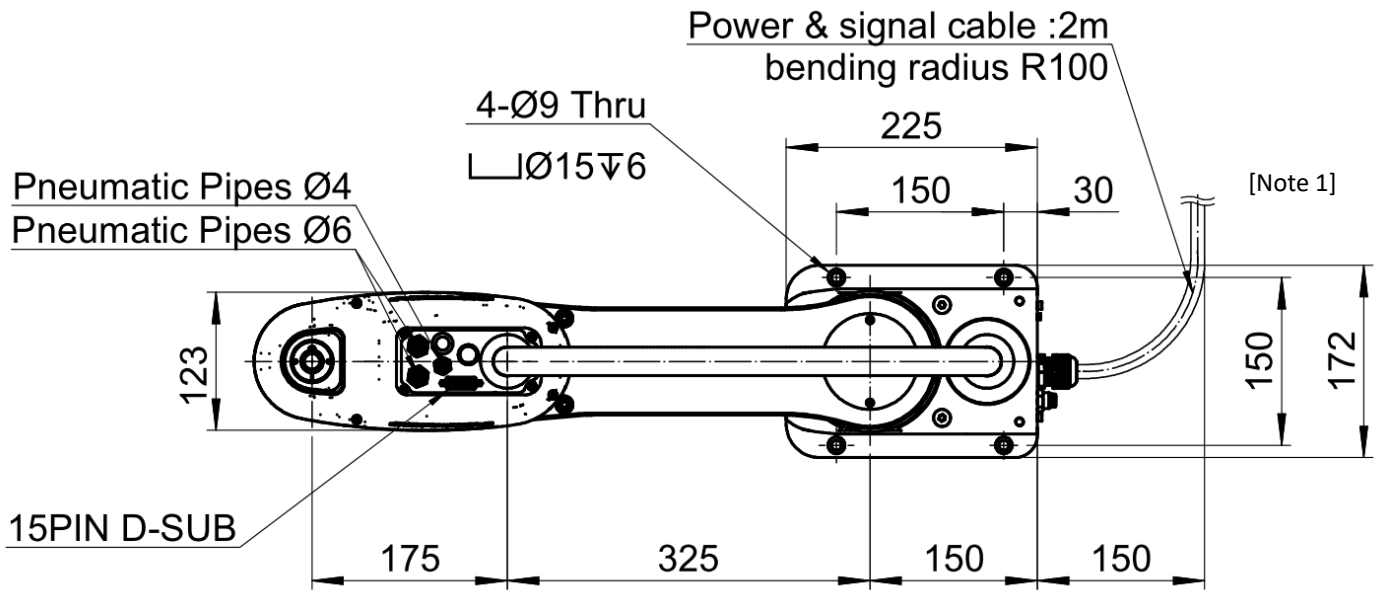

[Note 1] Cable bending radius of at least 150mm, please reserve space to deploy the cable

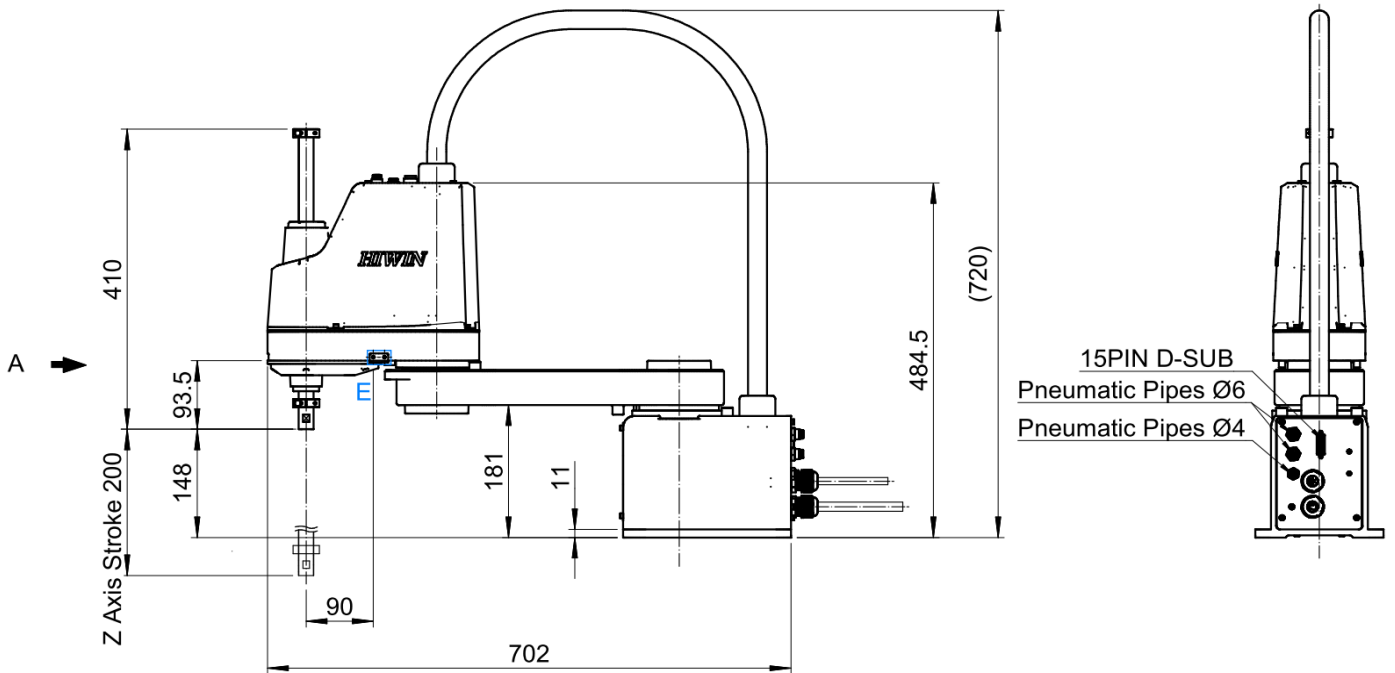

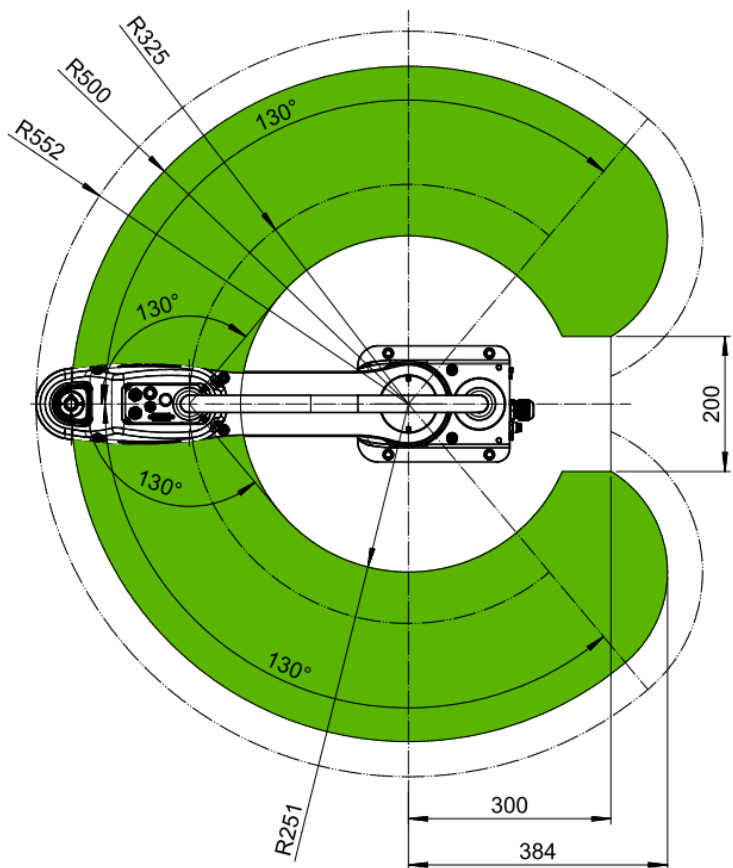
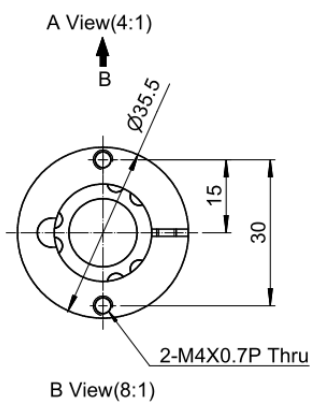
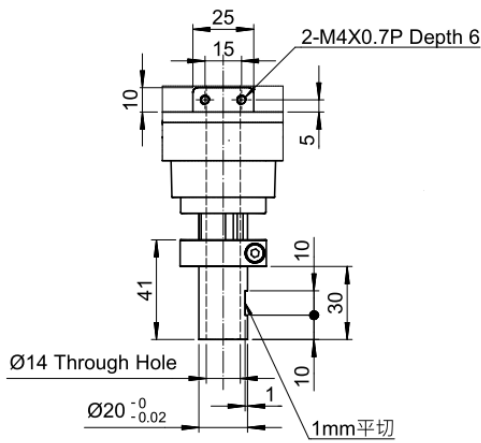
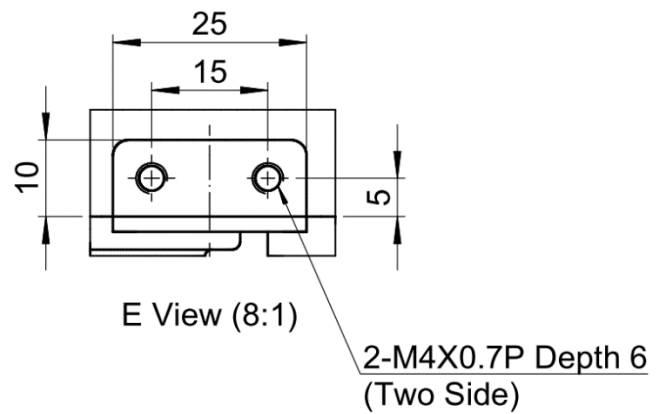
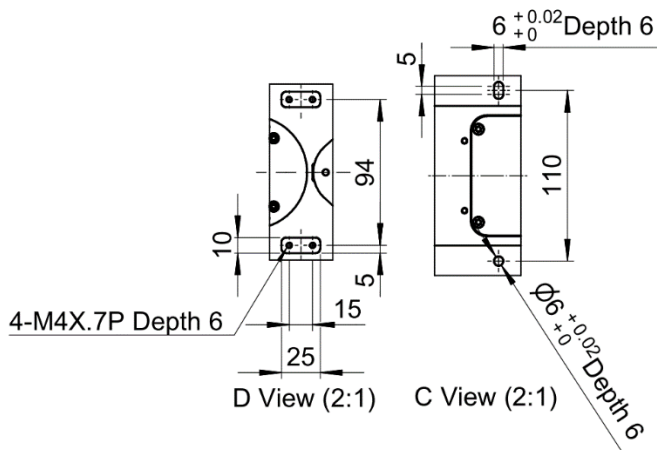
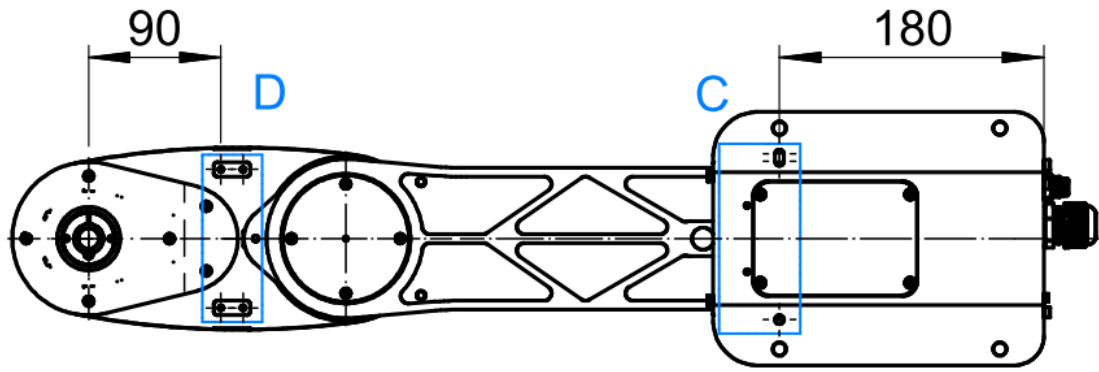

2.4.4. RS405-500-400-LU

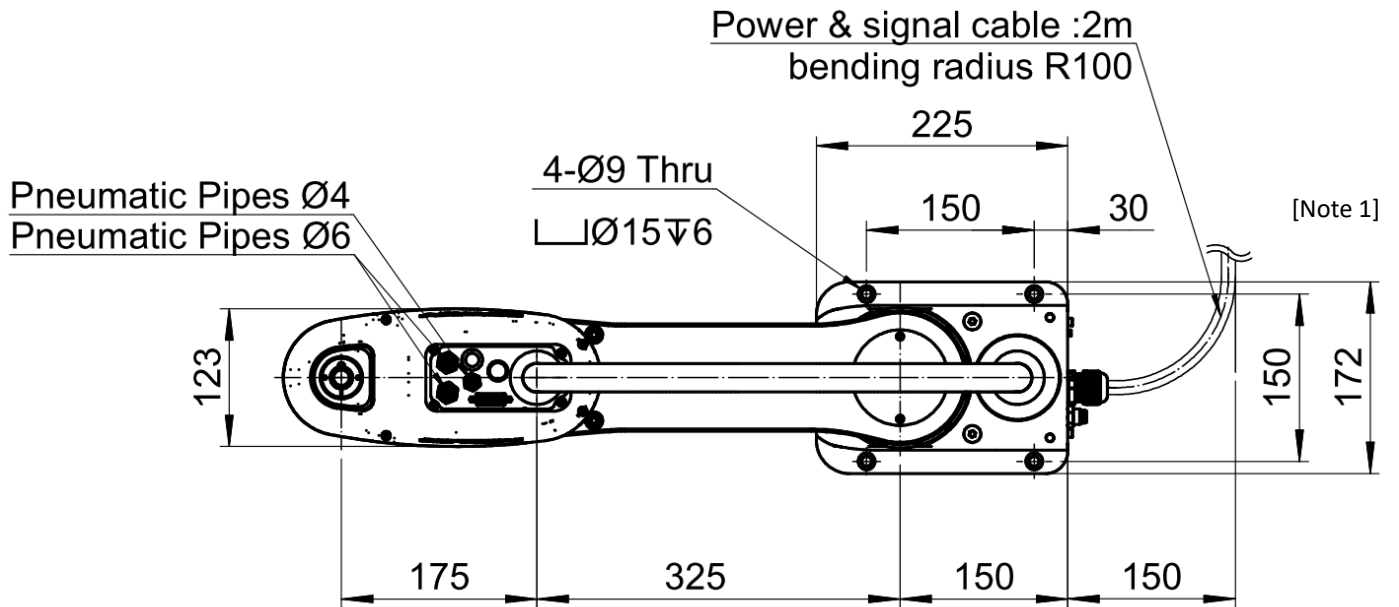

[Note 1] Cable bending radius of at least 150mm, please reserve space to deploy the cable

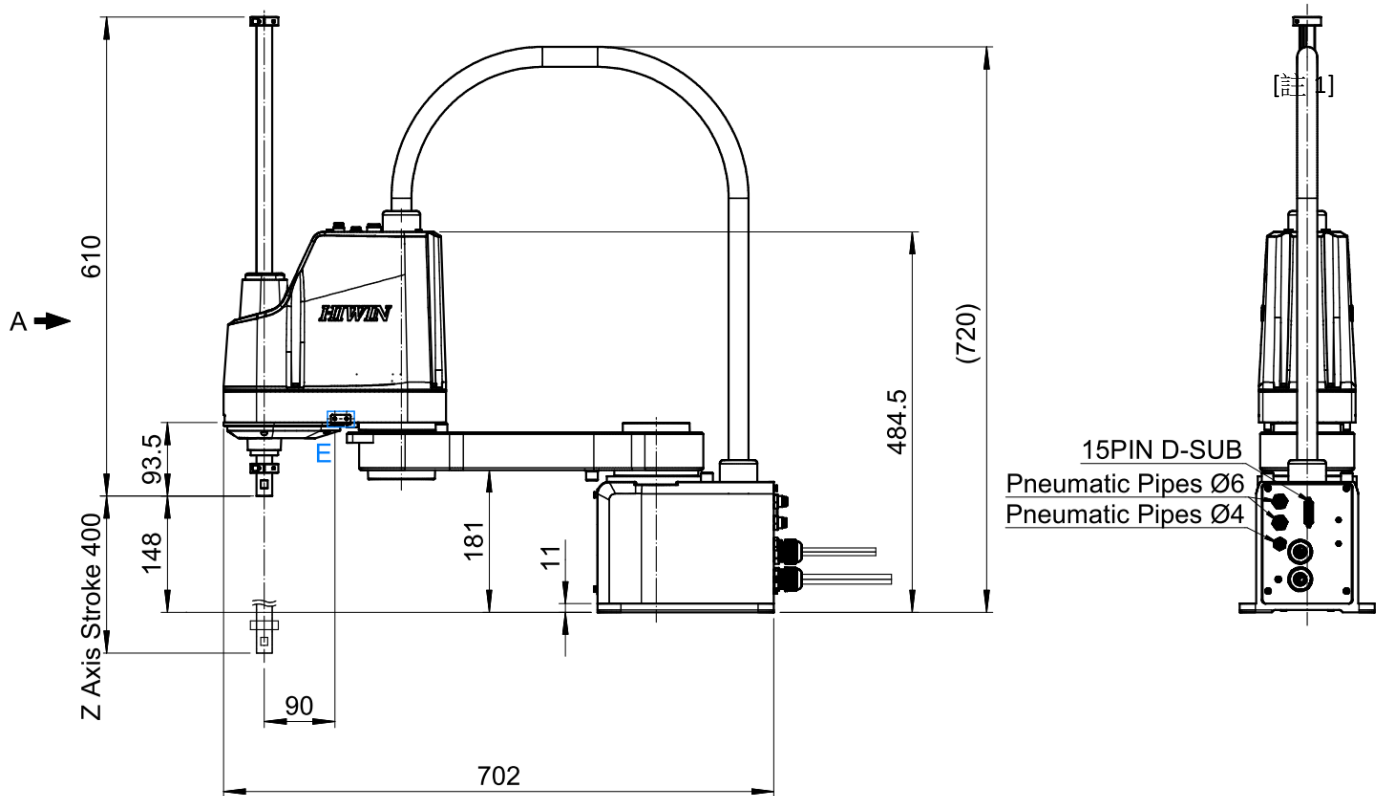

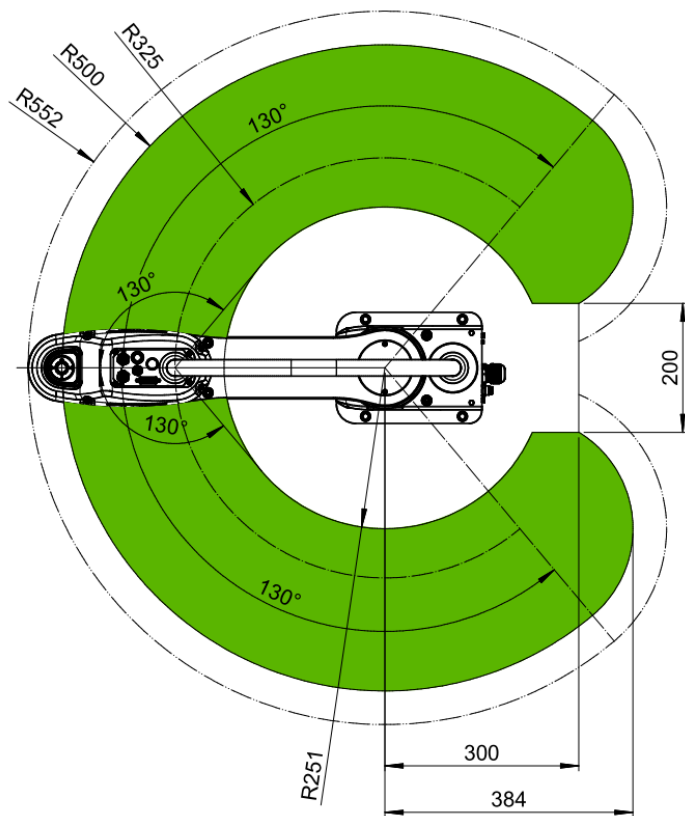
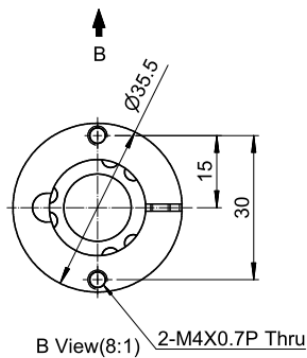
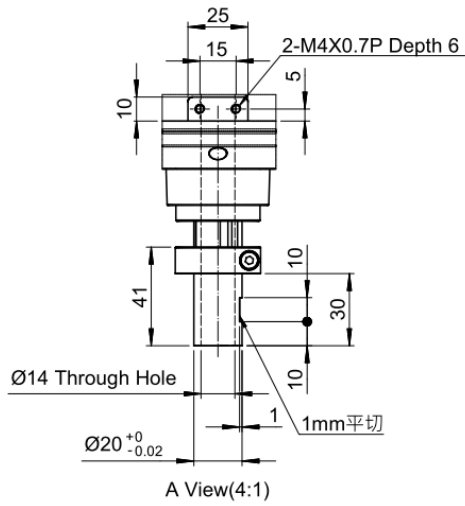
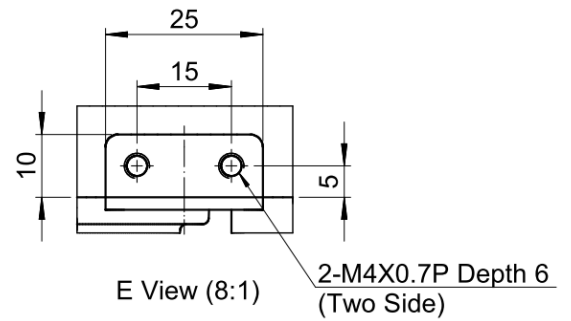
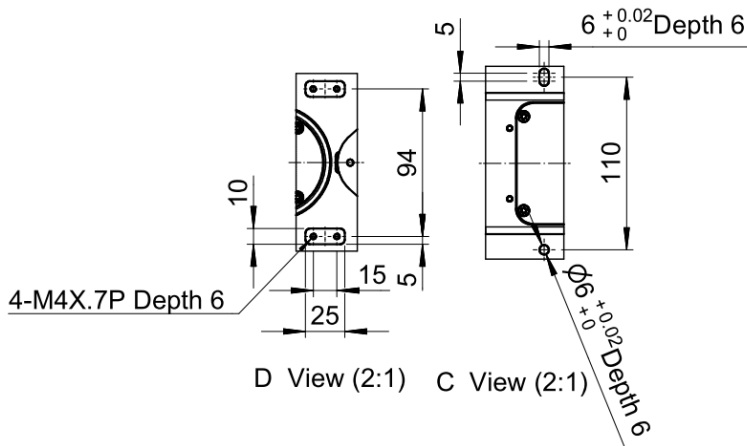
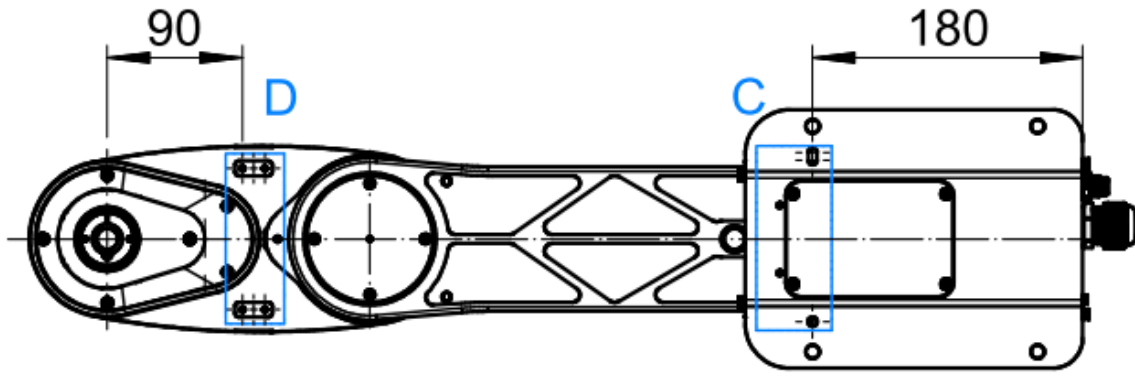

2.4.5. RS410-600-200-LU

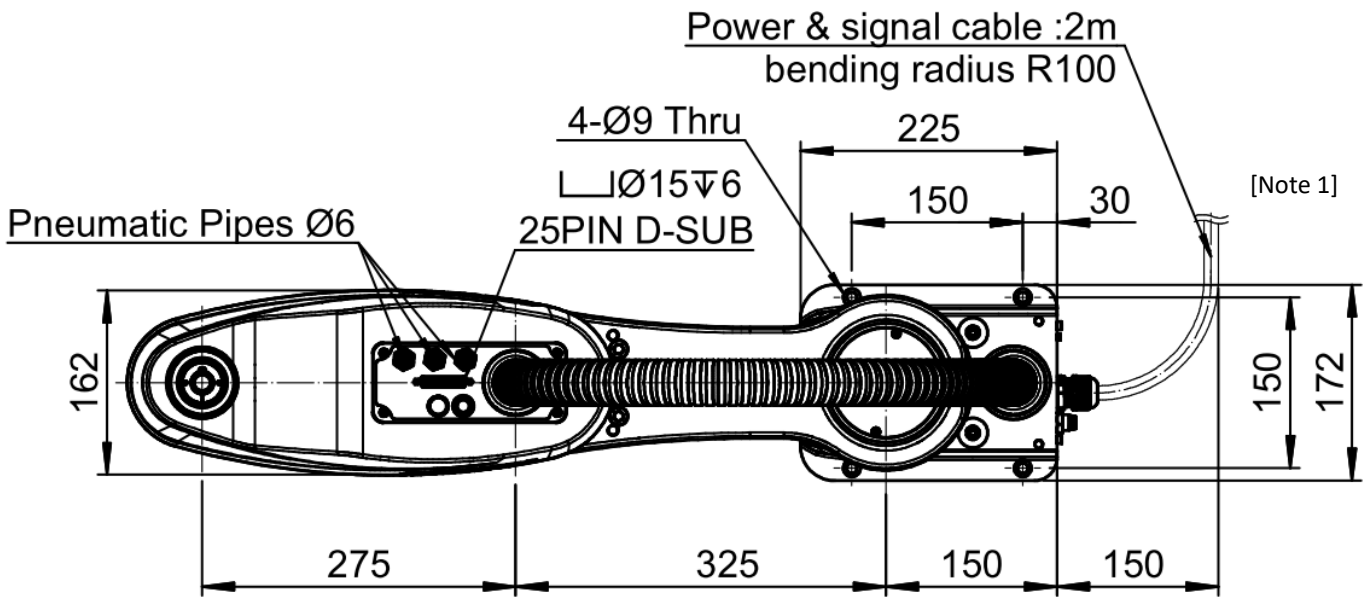

[Note 1] Cable bending radius of at least 150mm, please reserve space to deploy the cable

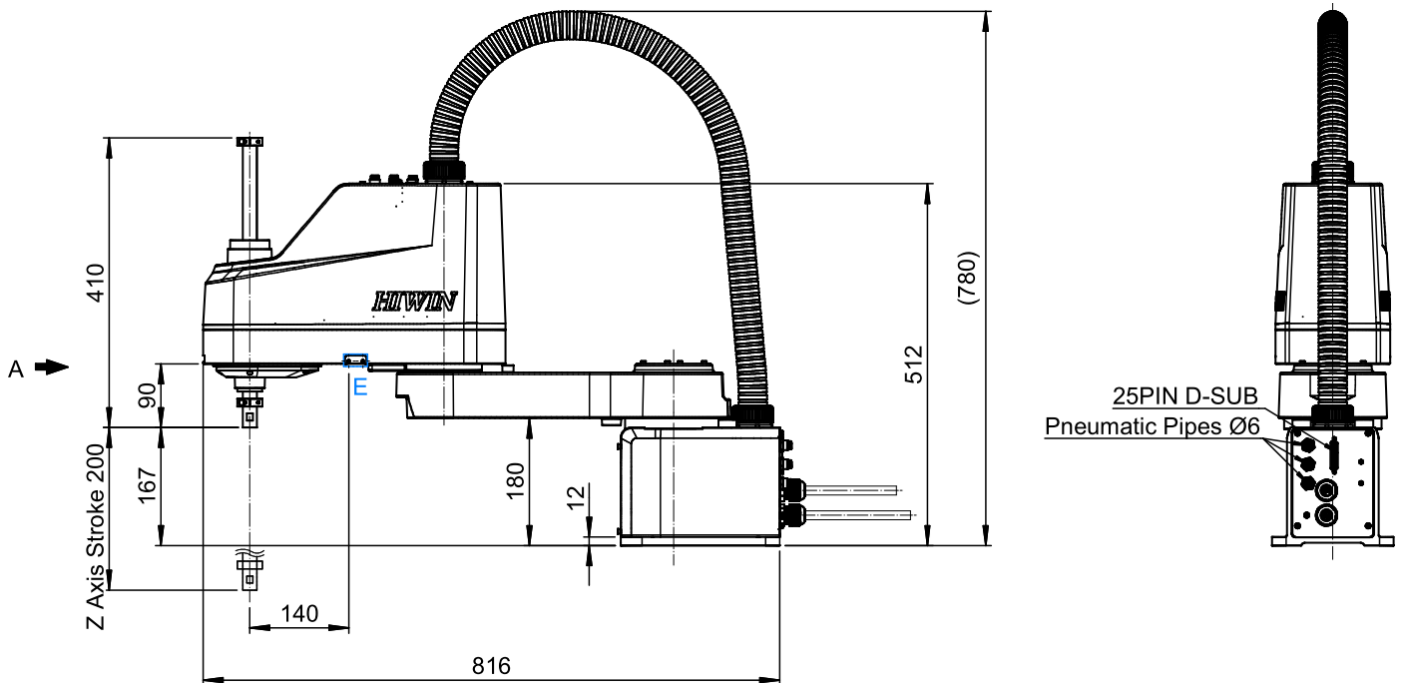

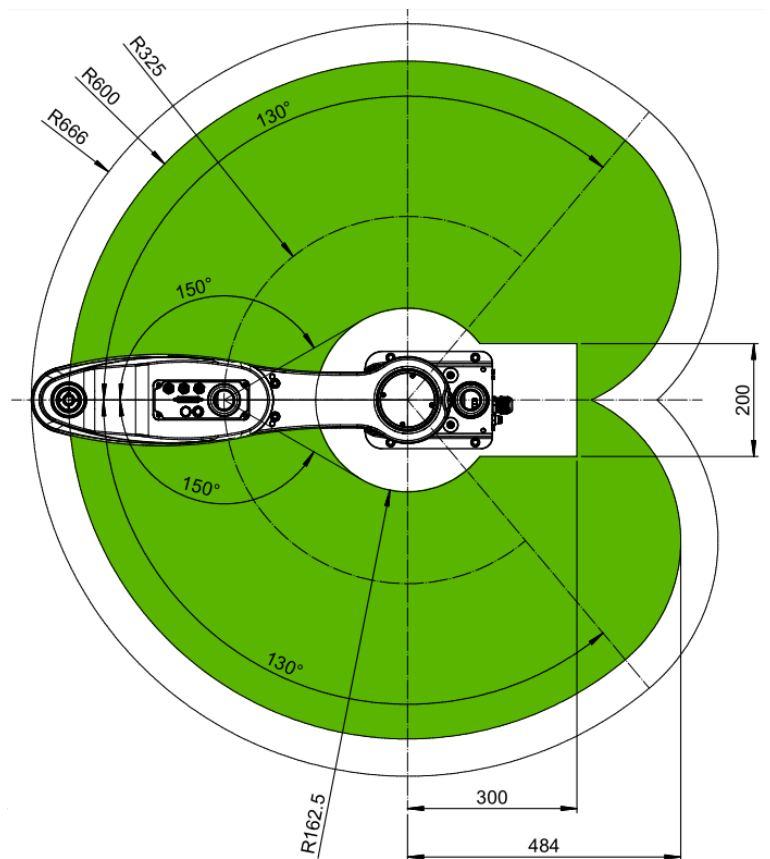
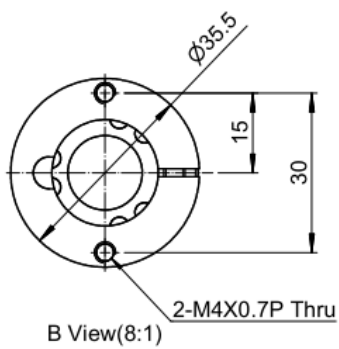
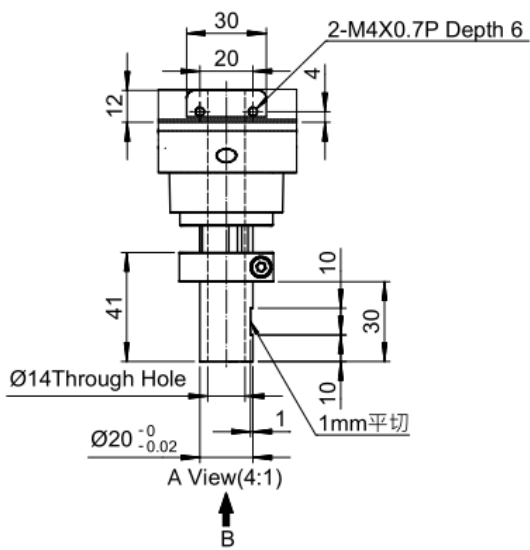
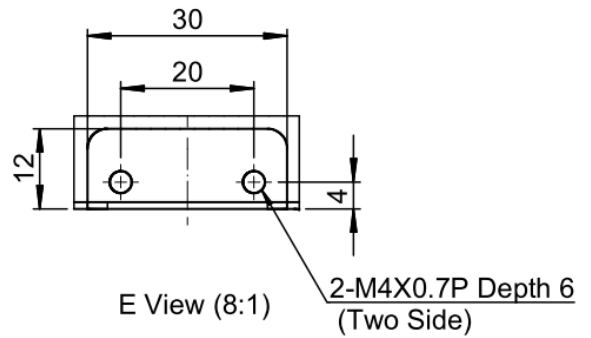
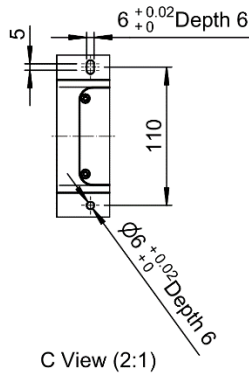
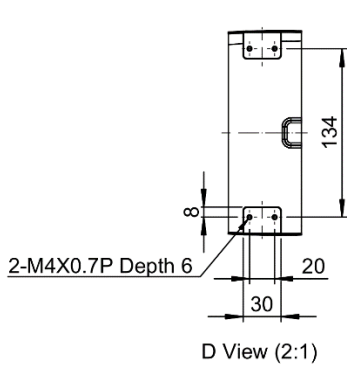
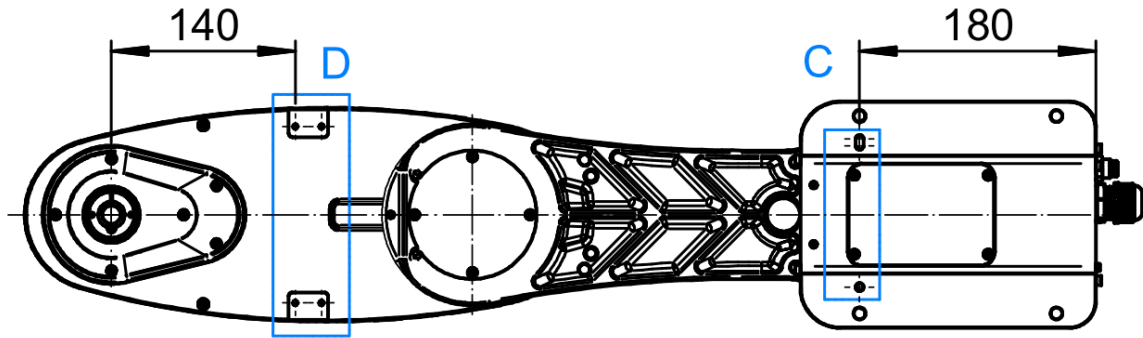

2.4.6. RS410-600-400-LU

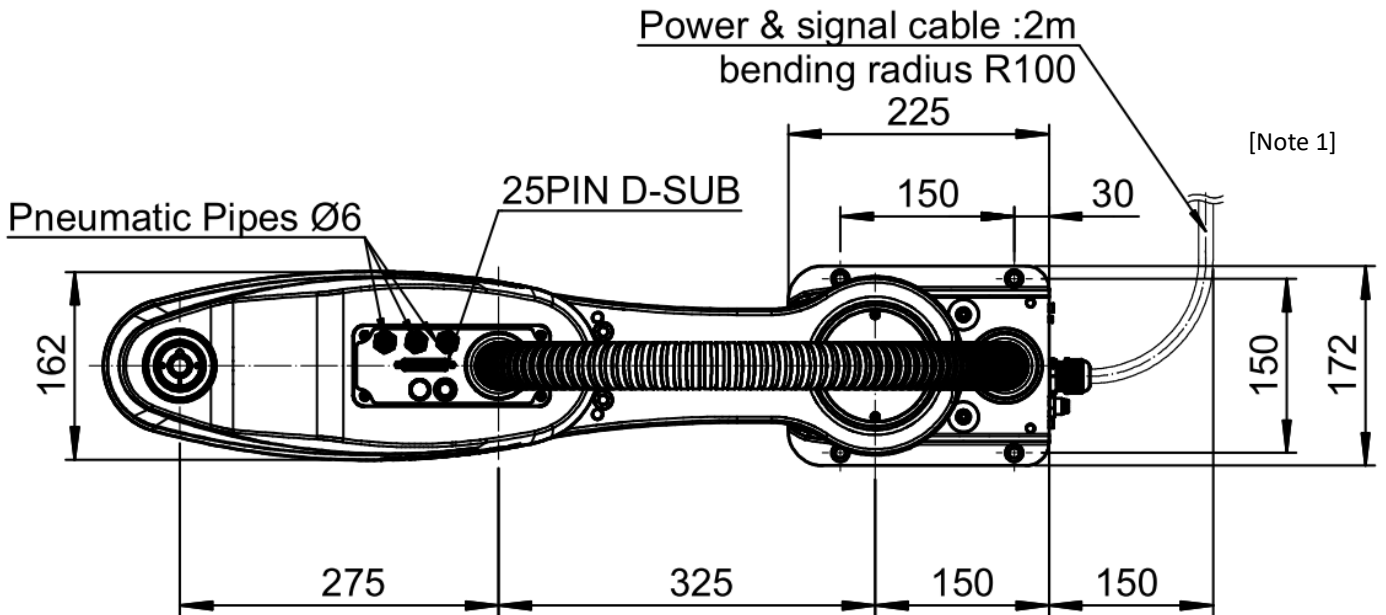

[Note 1] Cable bending radius of at least 150mm, please reserve space to deploy the cable

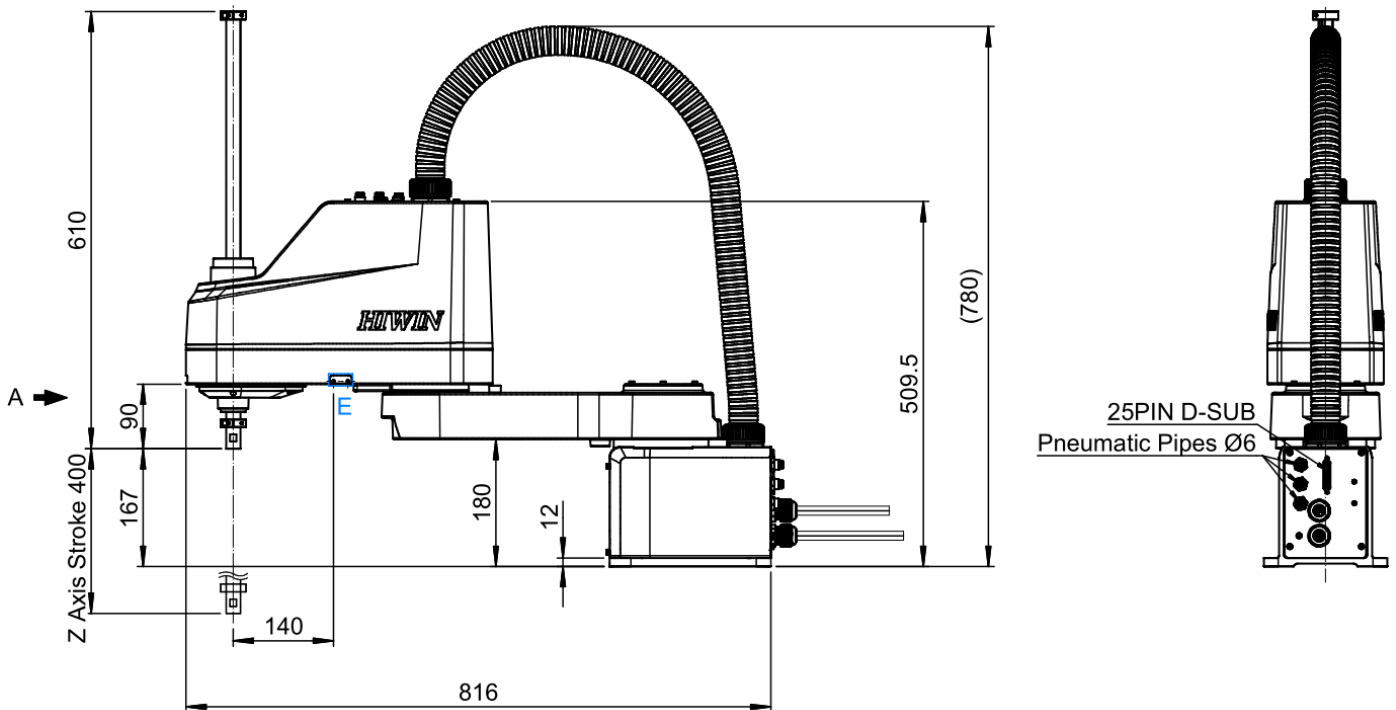

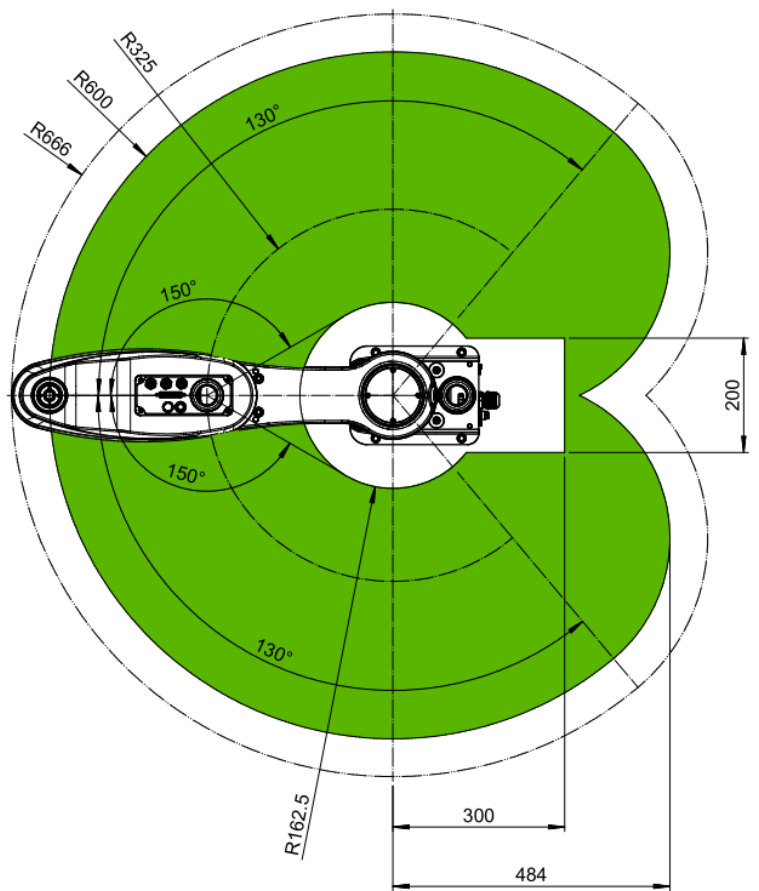
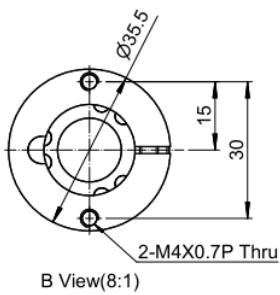
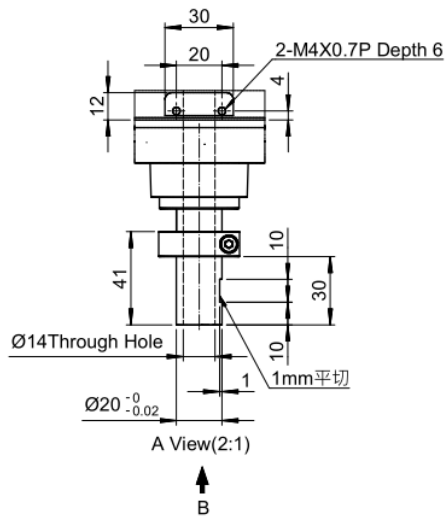
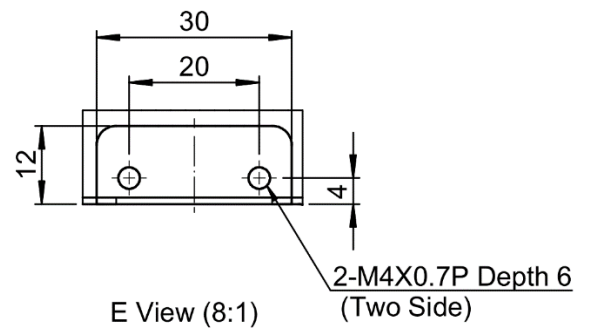
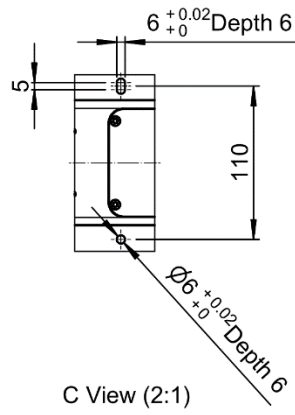
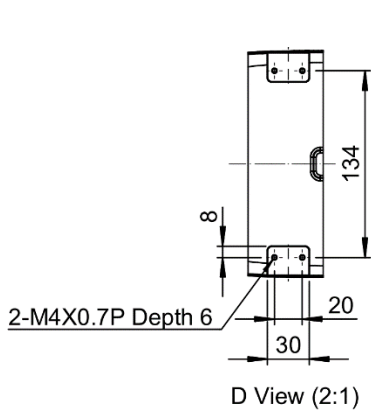
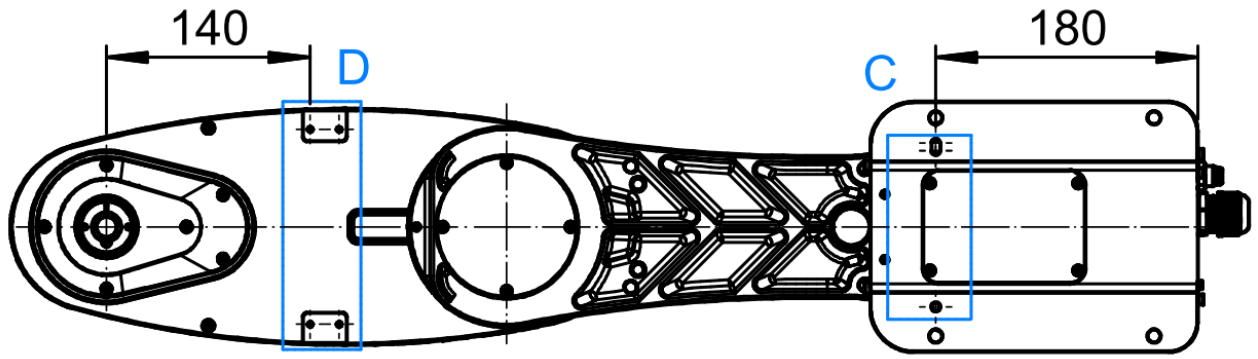

2.4.7. RS410-700-200-LU

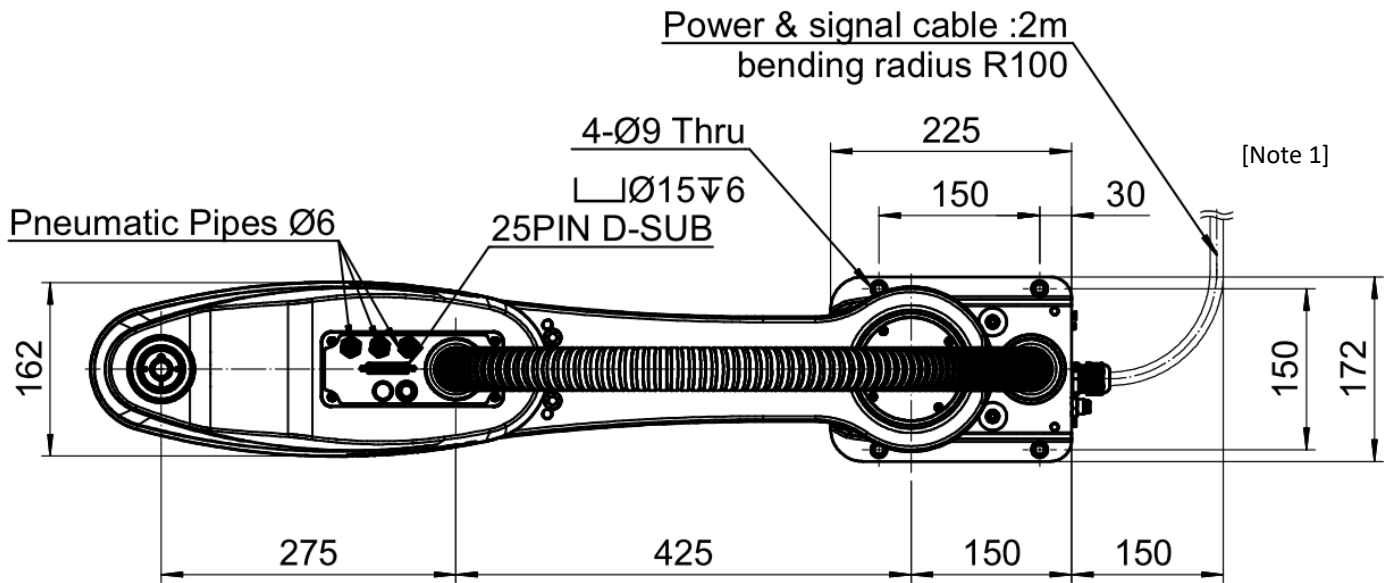

[Note 1] Cable bending radius of at least 150mm, please reserve space to deploy the cable

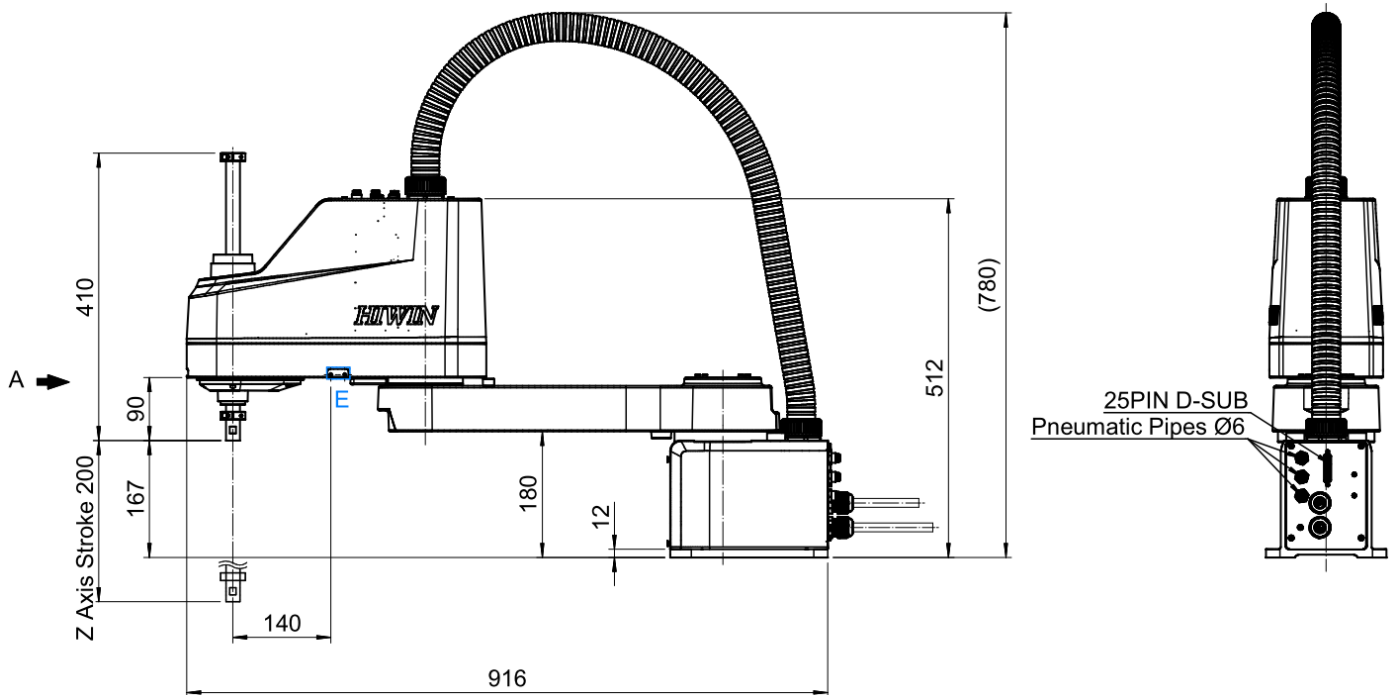

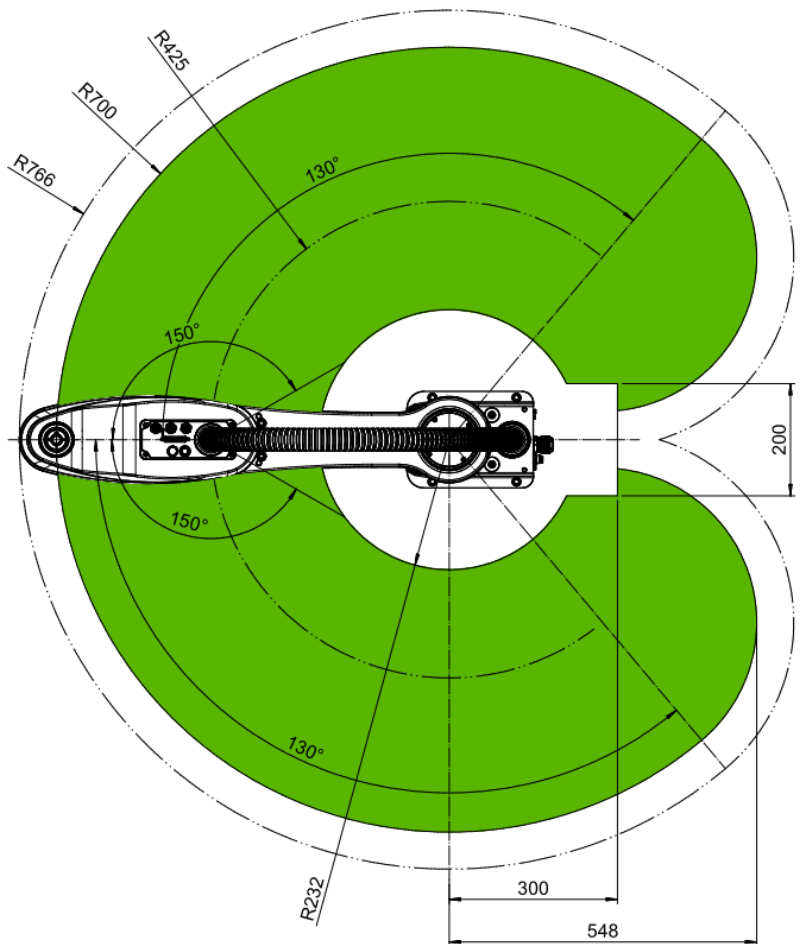
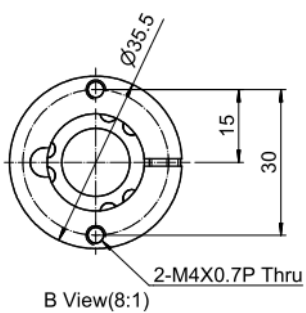
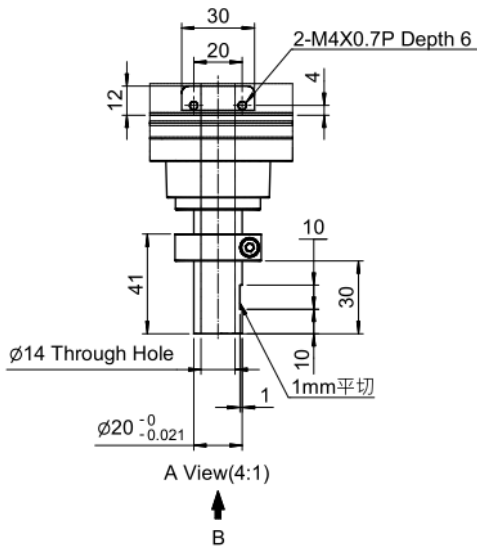
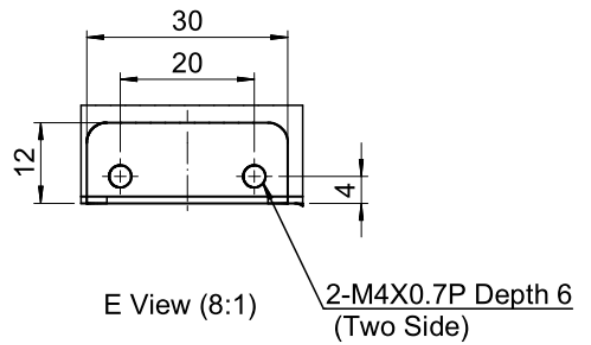
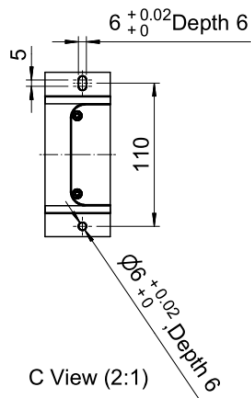
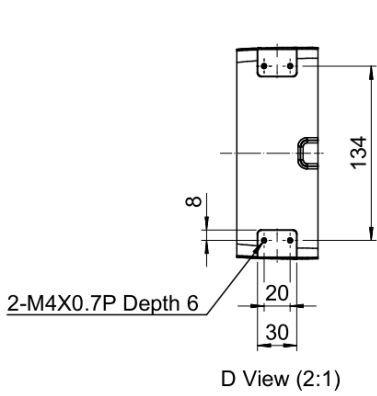
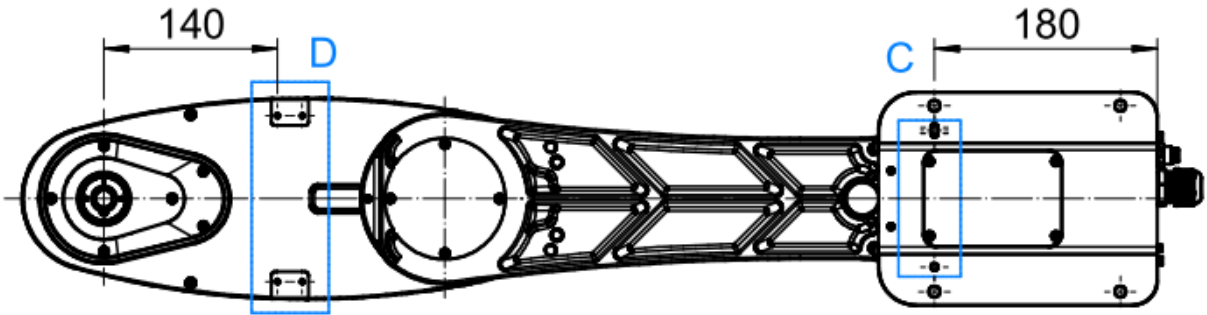

2.4.8. RS410-700-400-LU

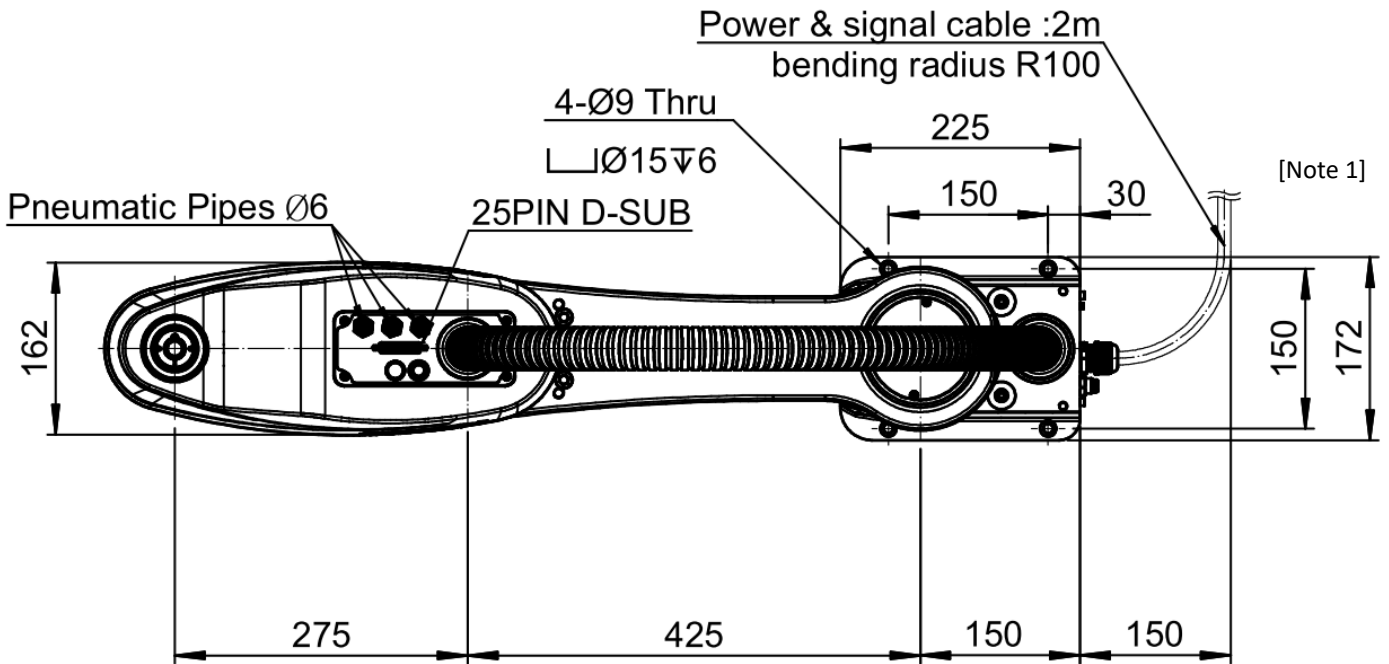

[Note 1] Cable bending radius of at least 150mm, please reserve space to deploy the cable

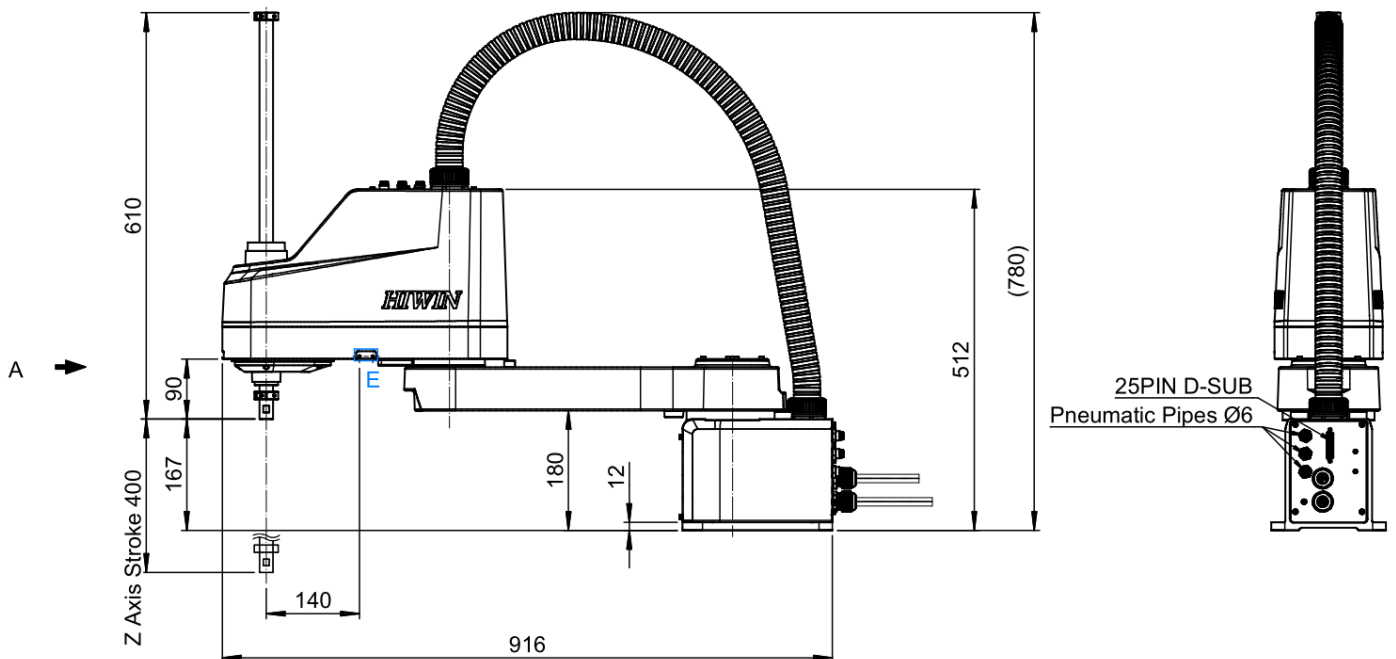

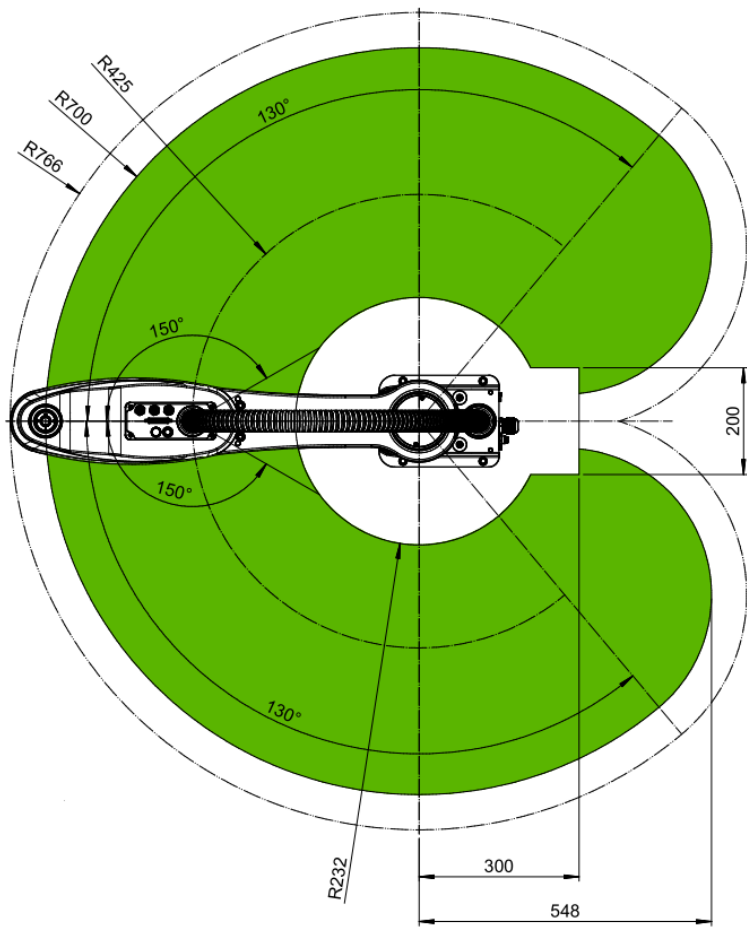
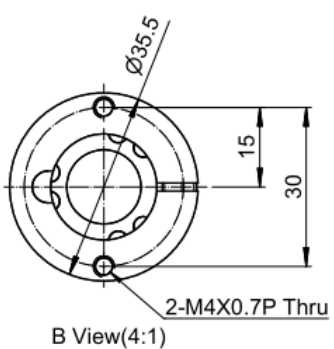
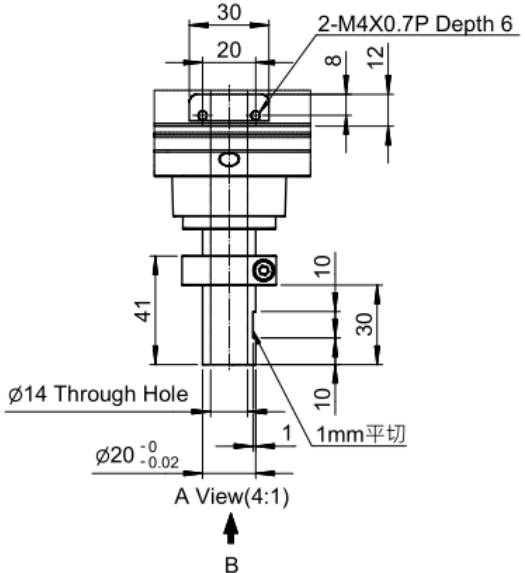
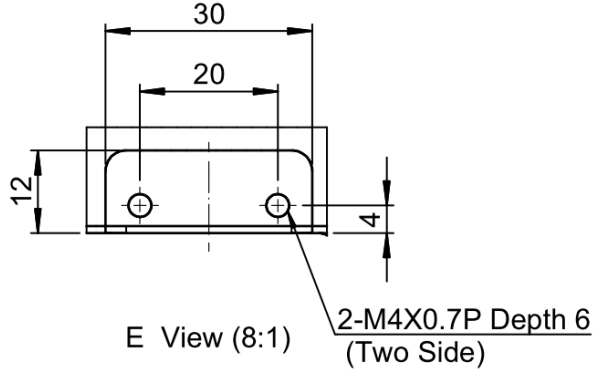
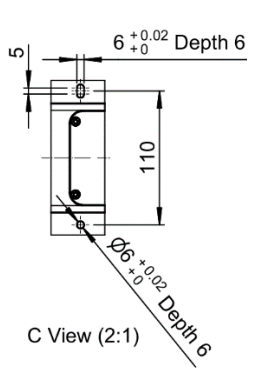
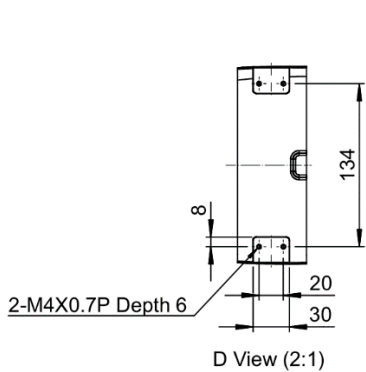
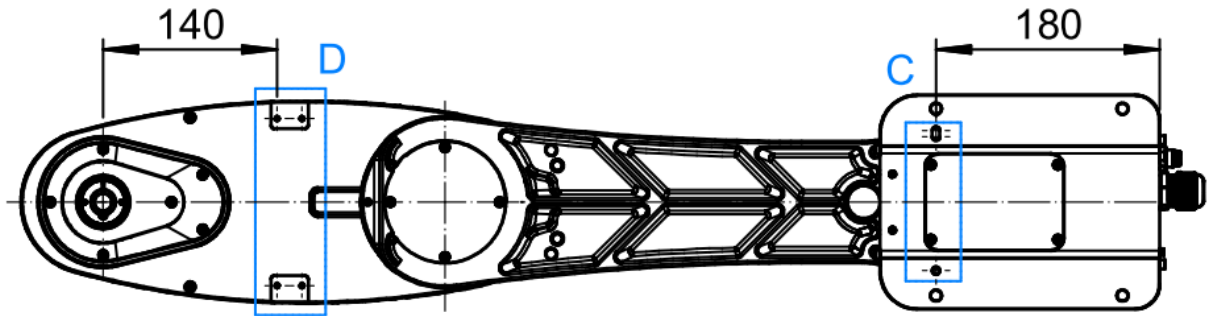

2.4.9. RS410-800-200-LU

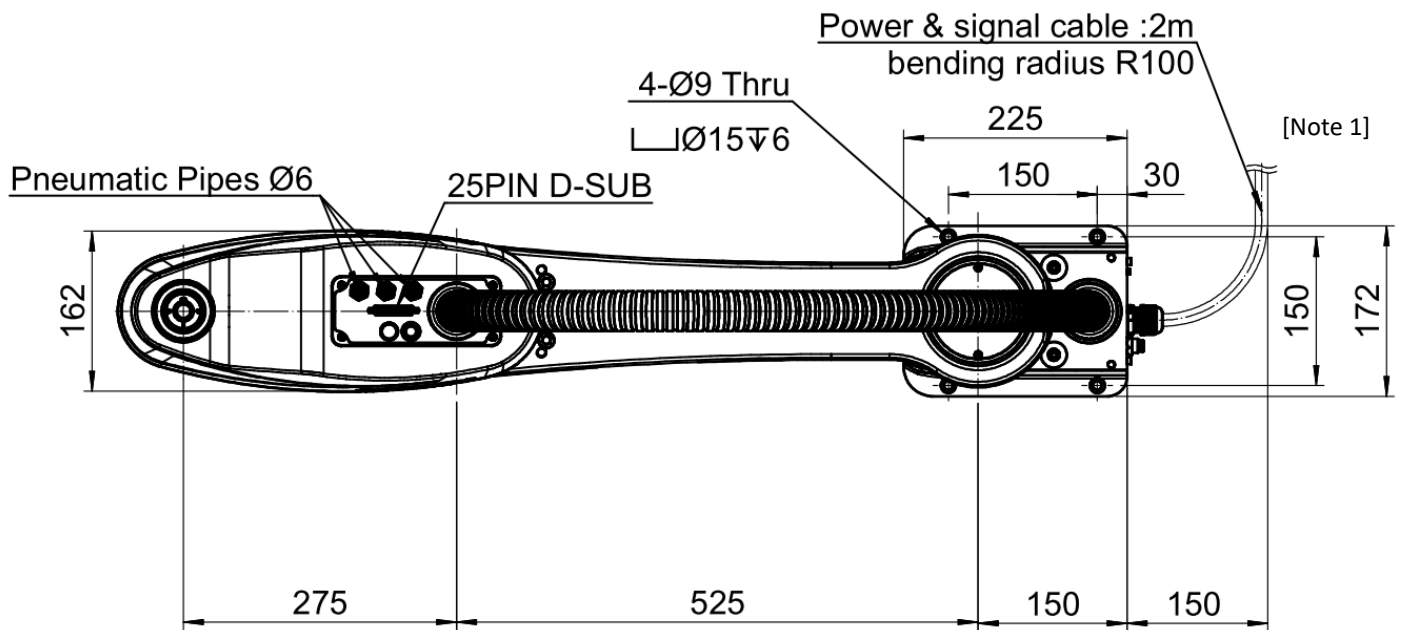

[Note 1] Cable bending radius of at least 150mm, please reserve space to deploy the cable

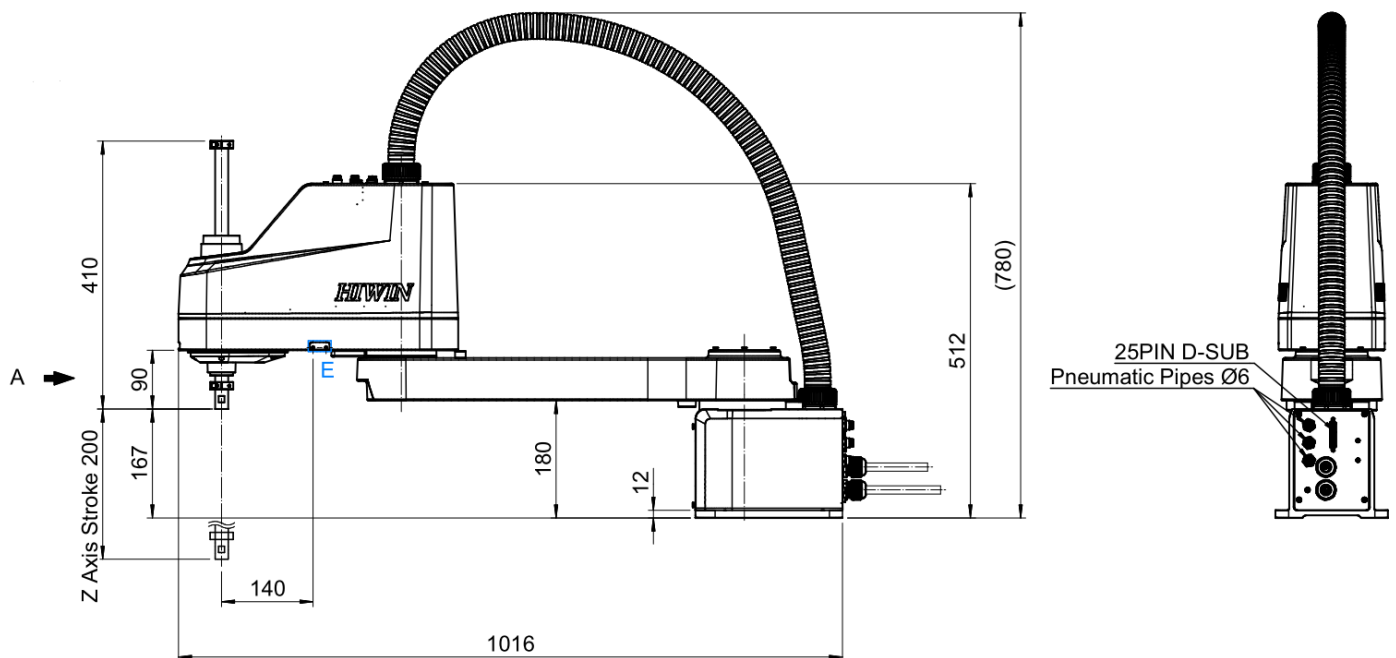

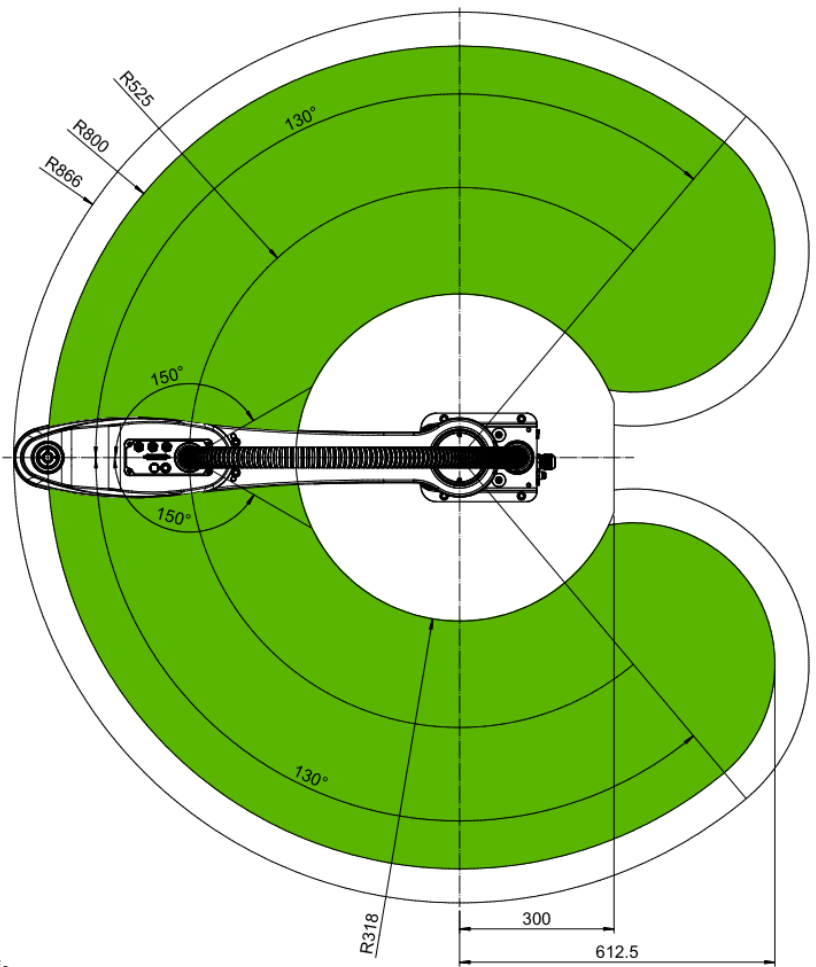
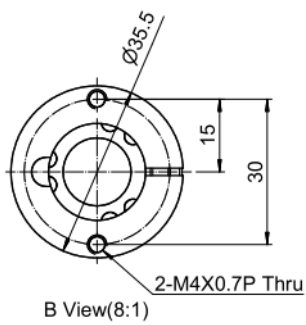
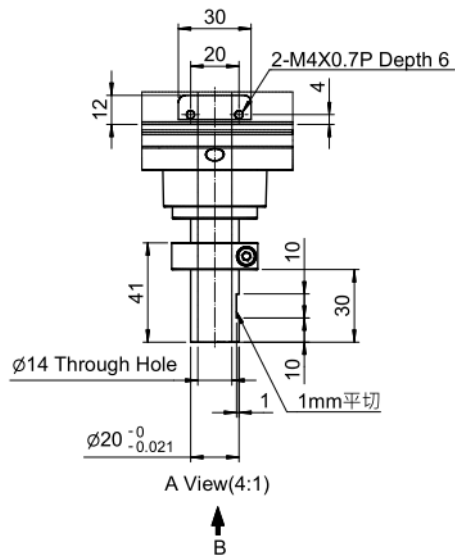
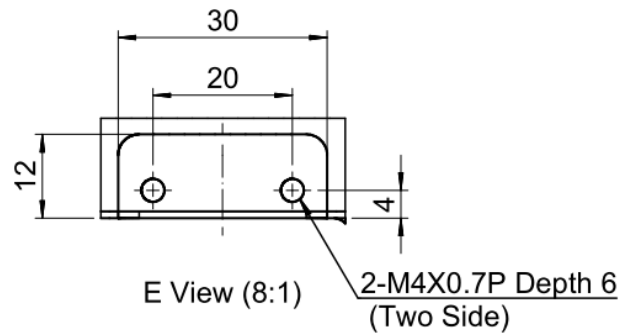
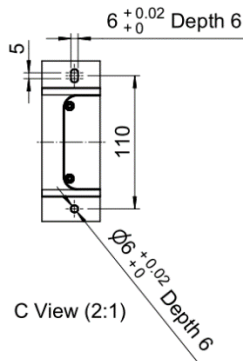
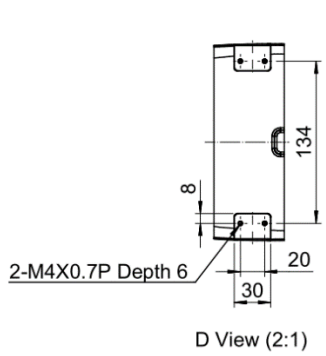
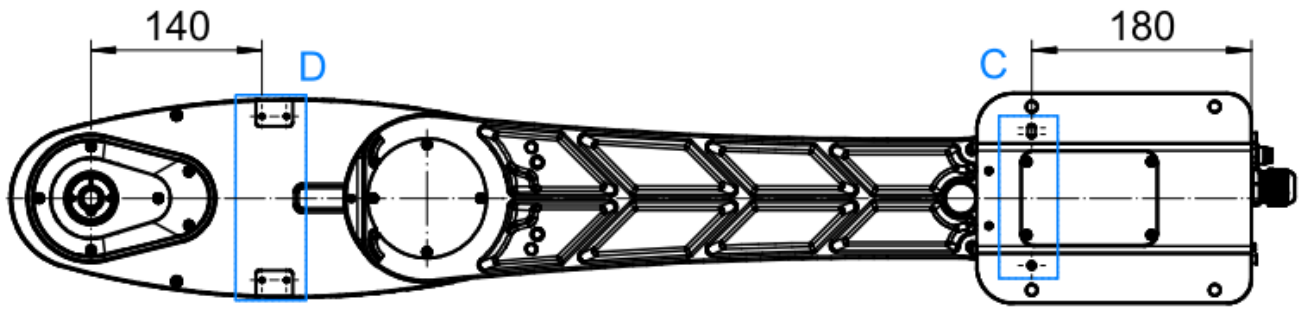

2.4.10. RS410-800-400-LU

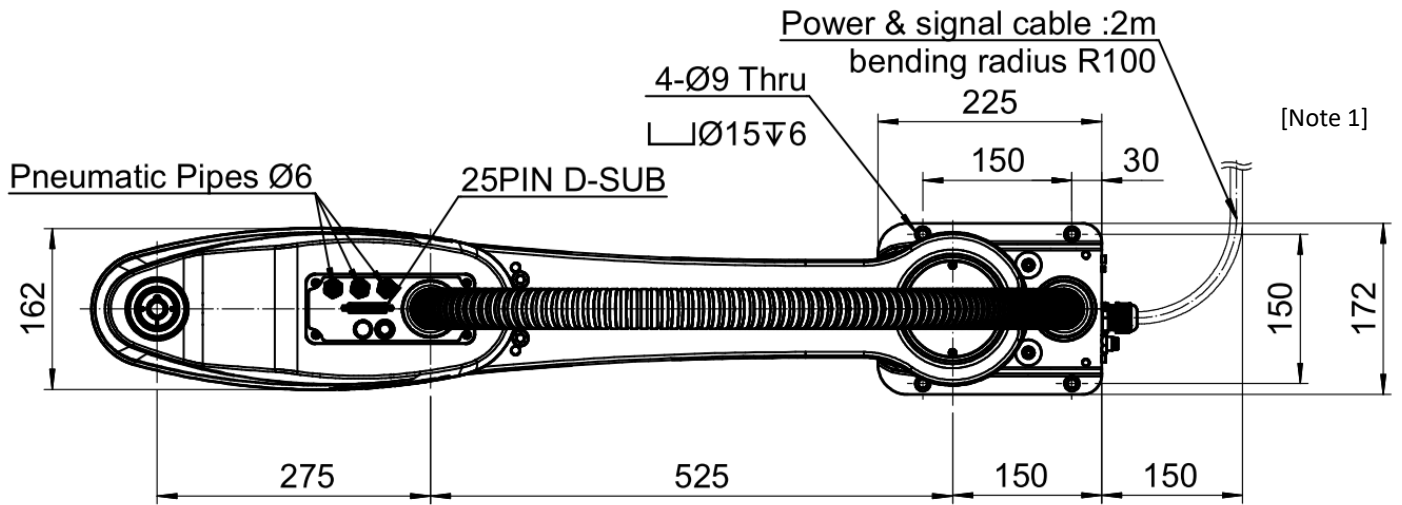

[Note 1] Cable bending radius of at least 150mm, please reserve space to deploy the cable

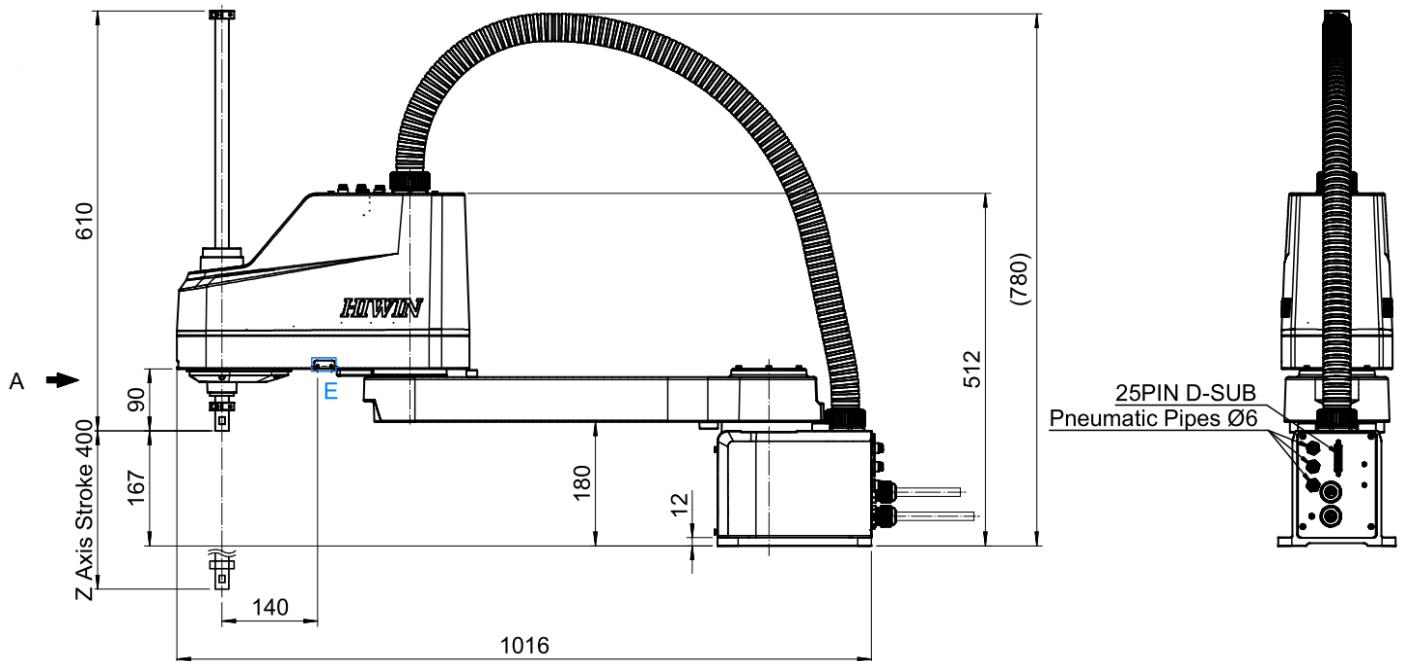

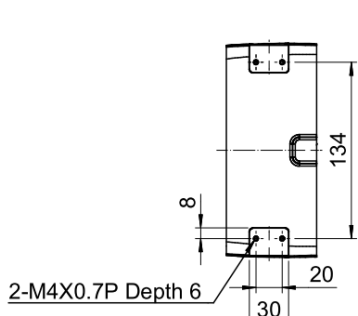
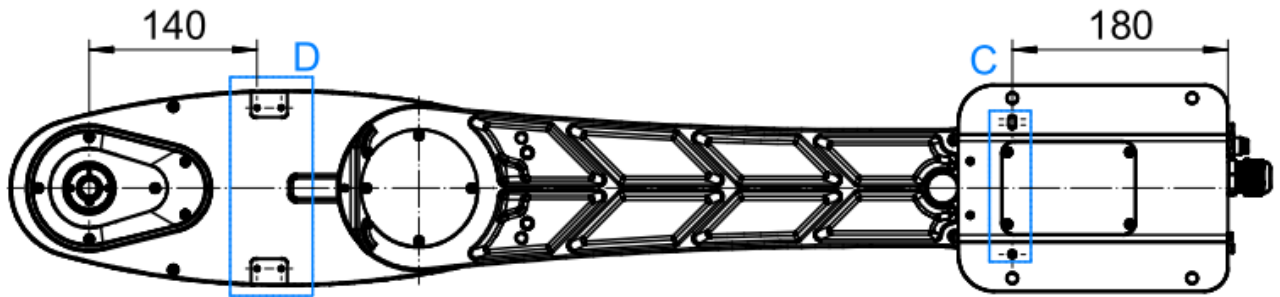

D View (2:1)

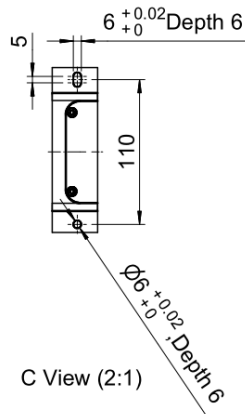

C View (2:1)

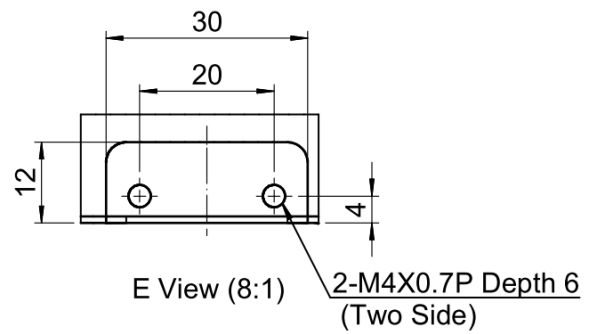

E View (8:1)

2-M4X0.7P Depth 6
(Two Side)

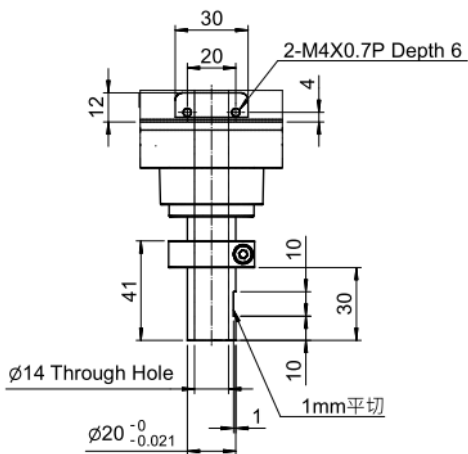

A View(4:1)

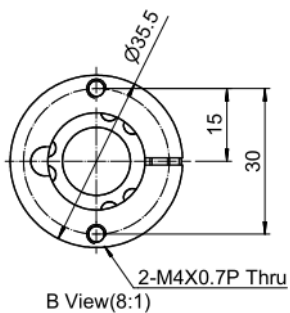

B View(8:1)

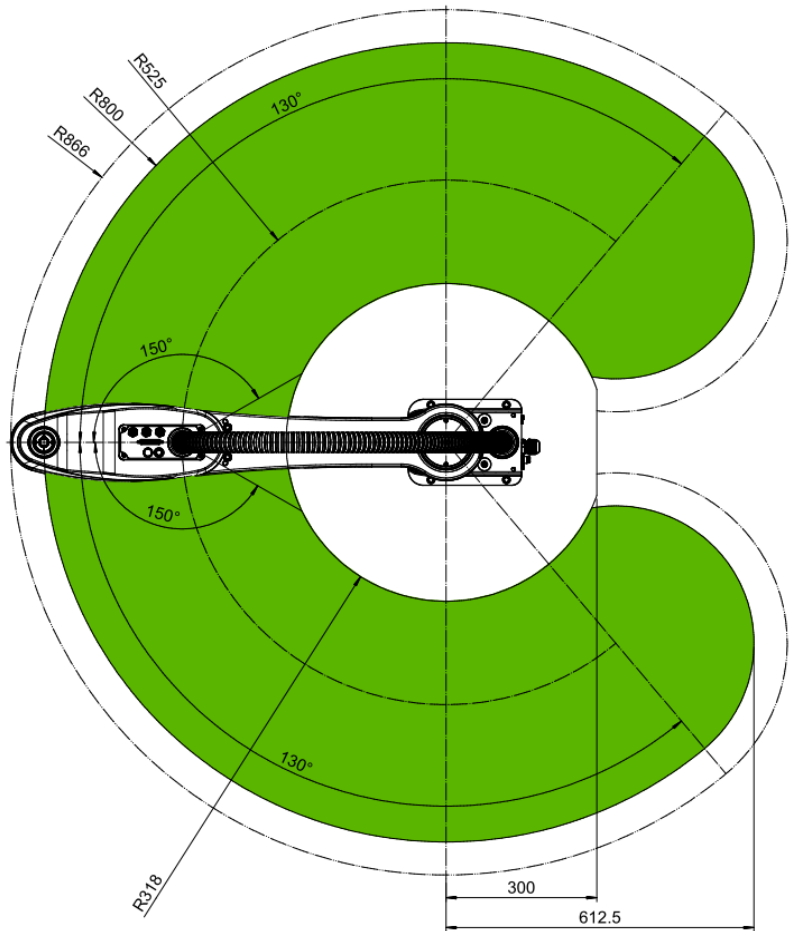

2.4.11. RS405-400-20P-LU

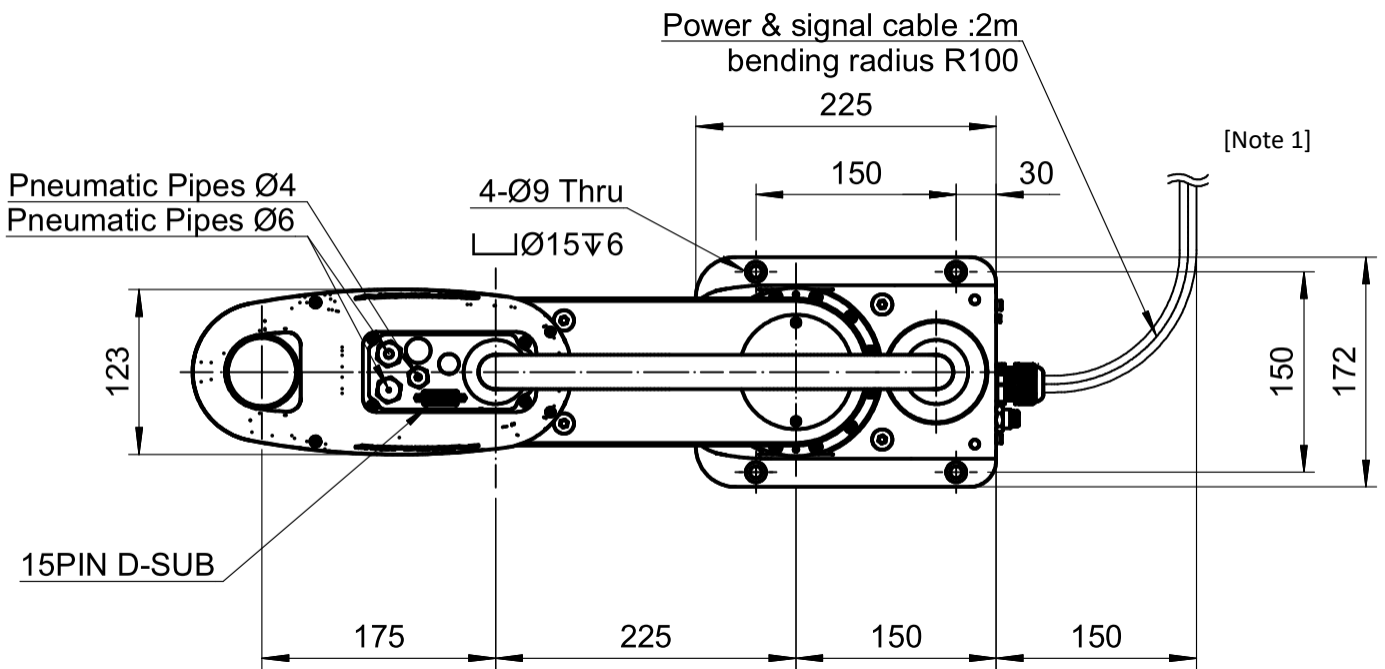

[Note 1] Cable bending radius of at least 150mm, please reserve space to deploy the cable

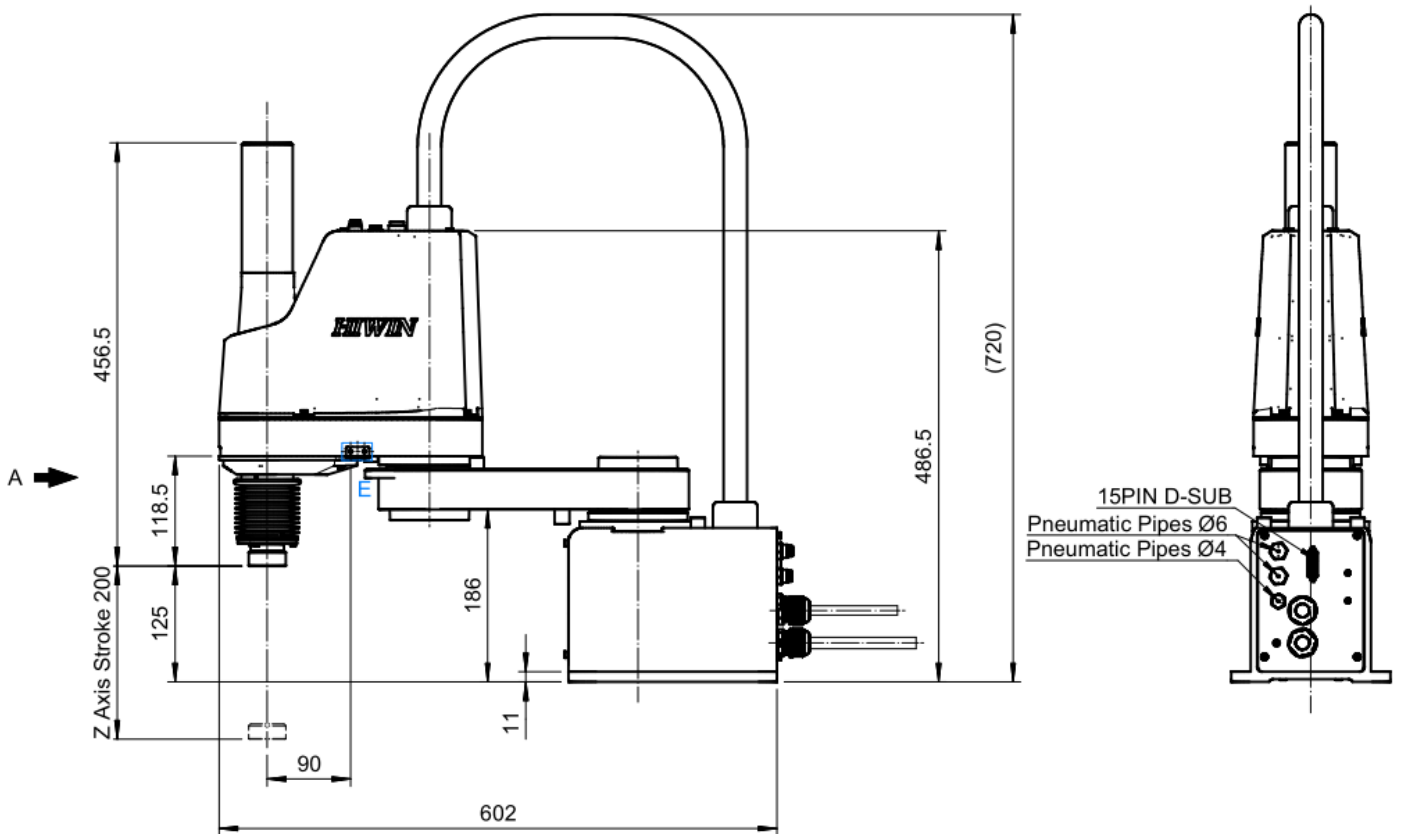

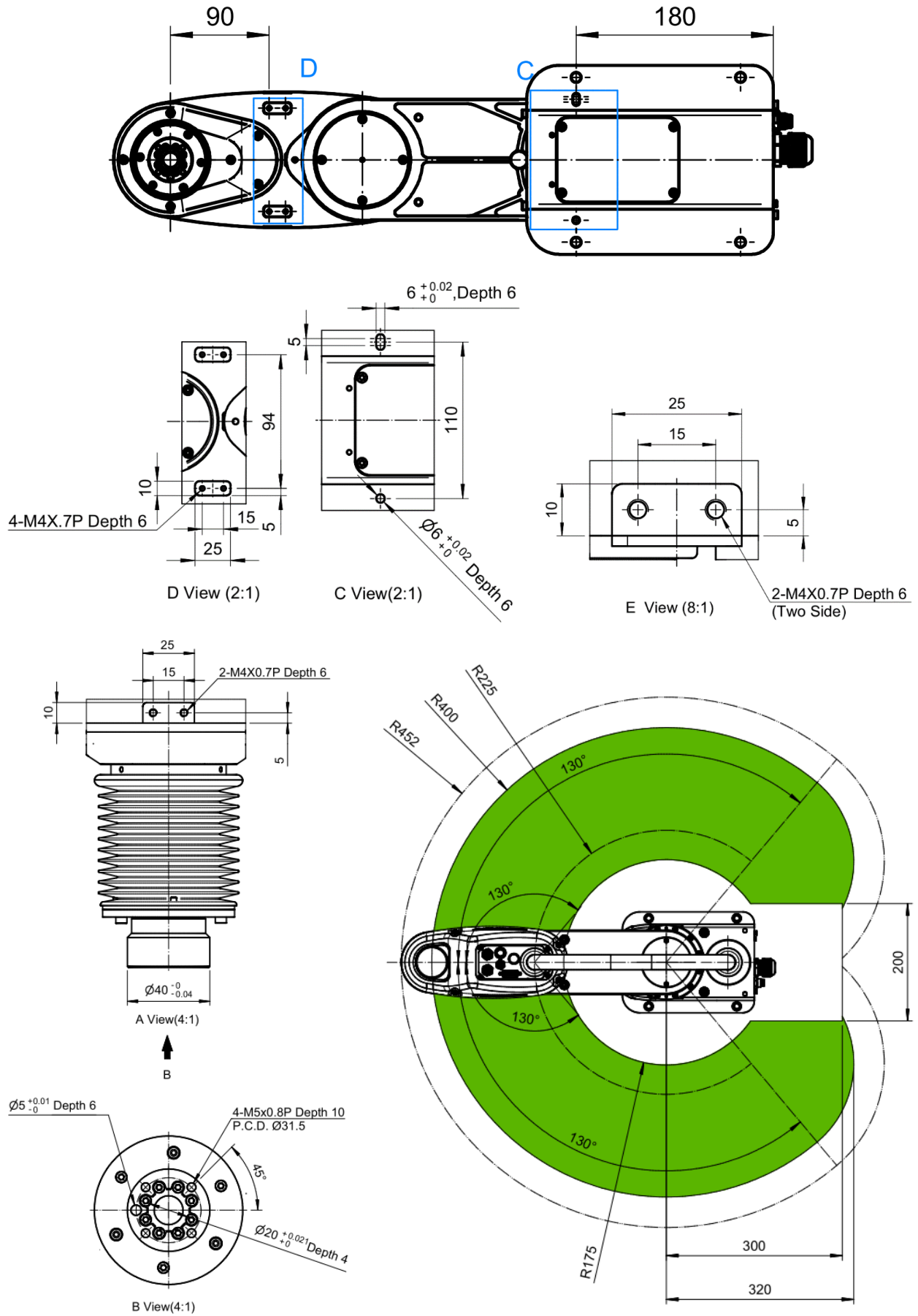

2.4.12. RS405-400-40P-LU

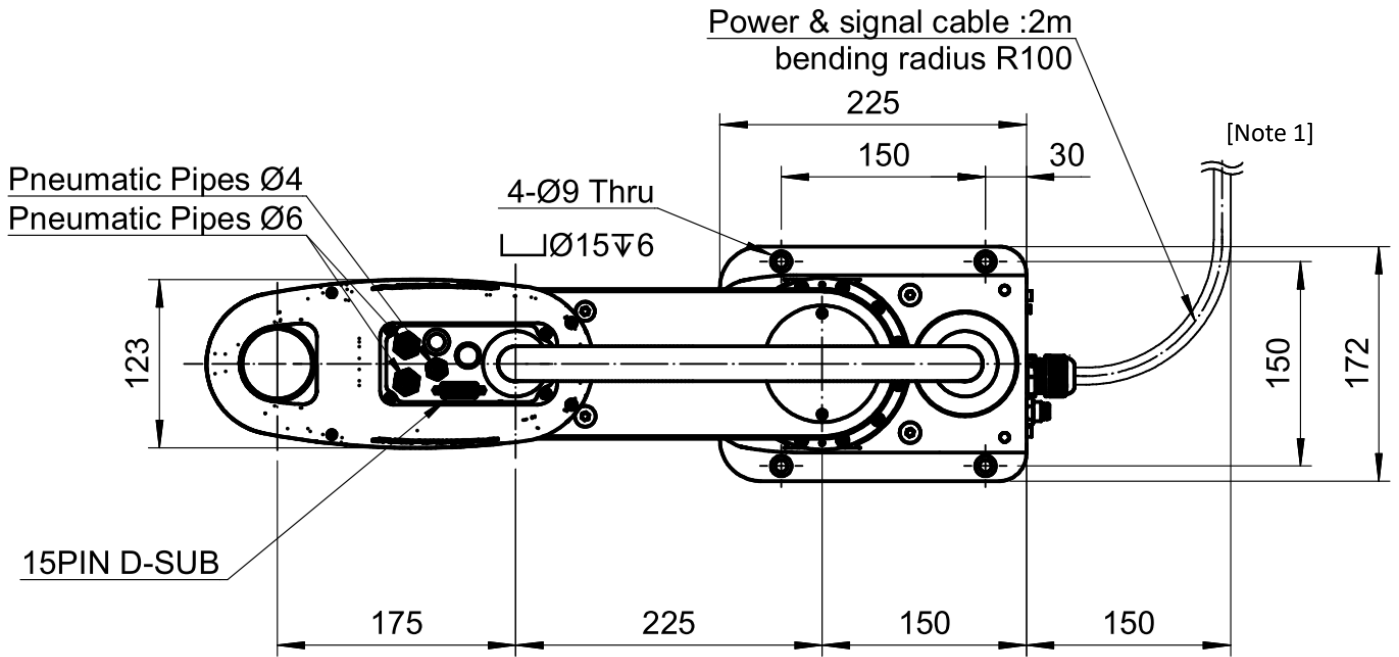

[Note 1] Cable bending radius of at least 150mm, please reserve space to deploy the cable

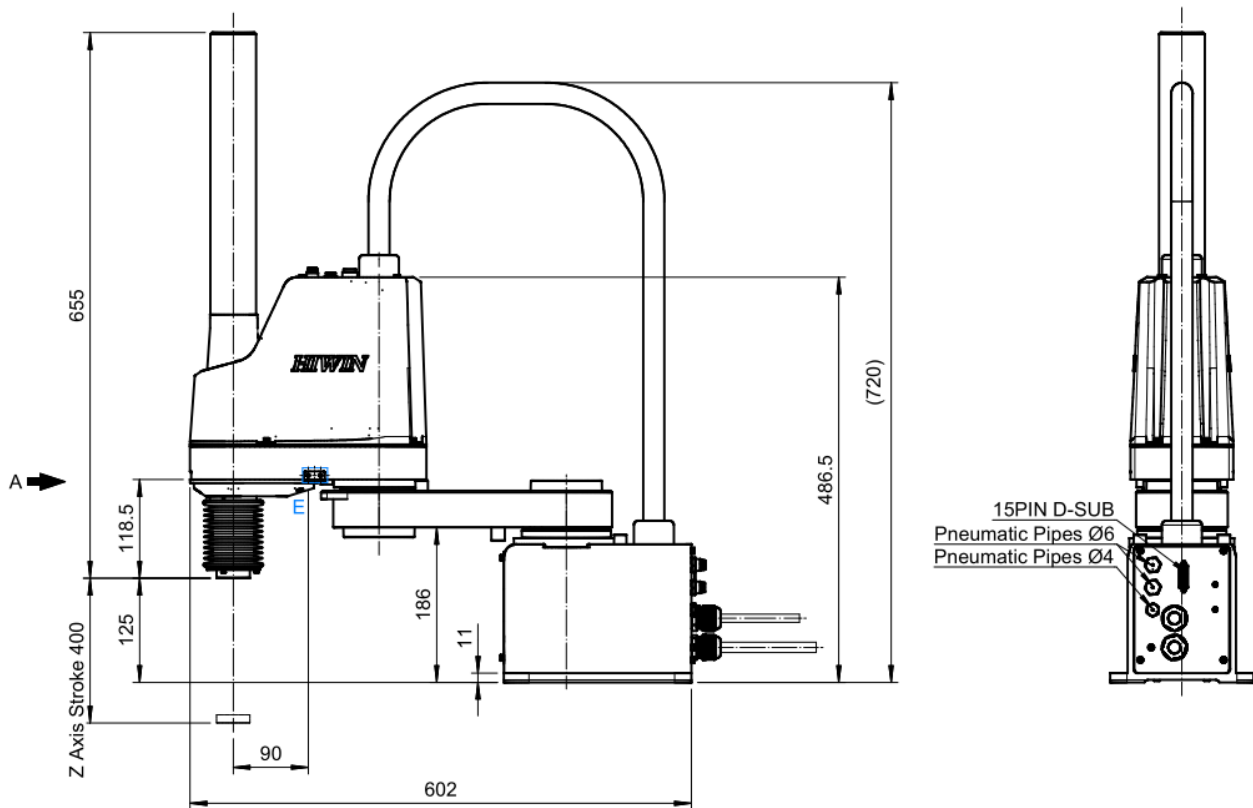

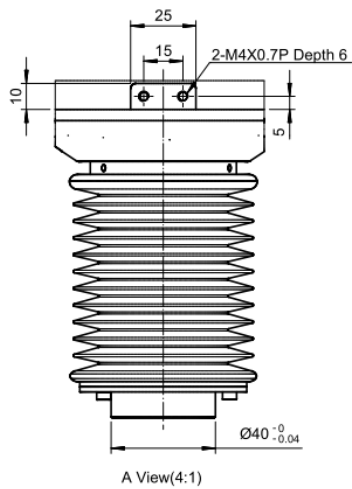
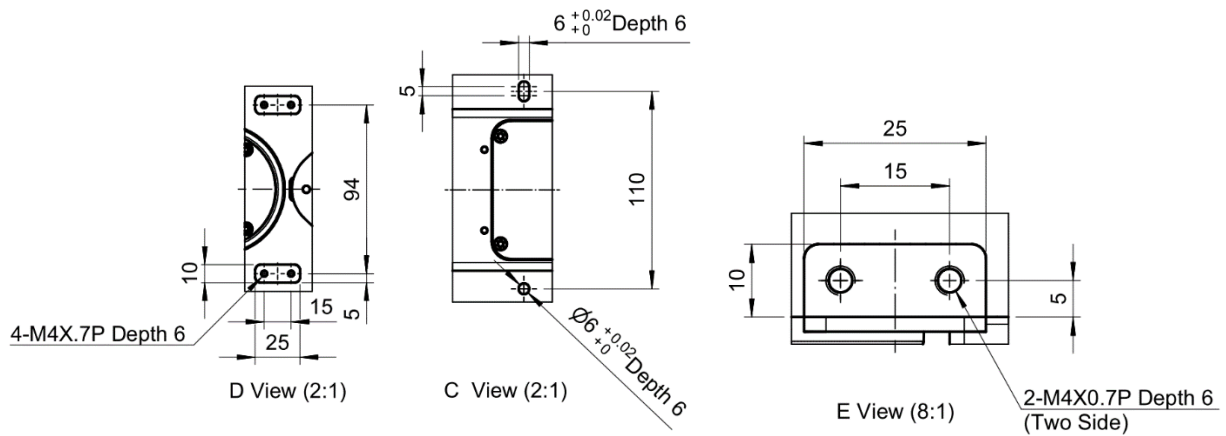
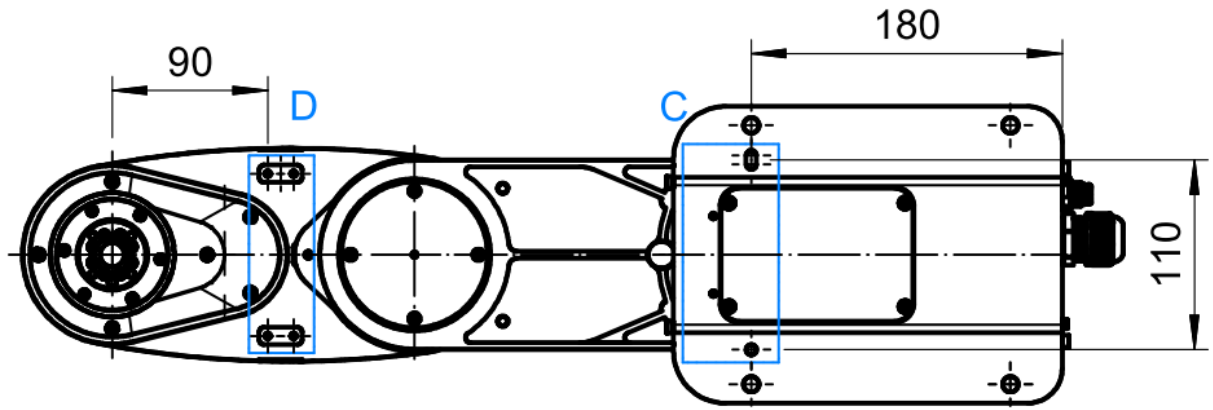

↑
B

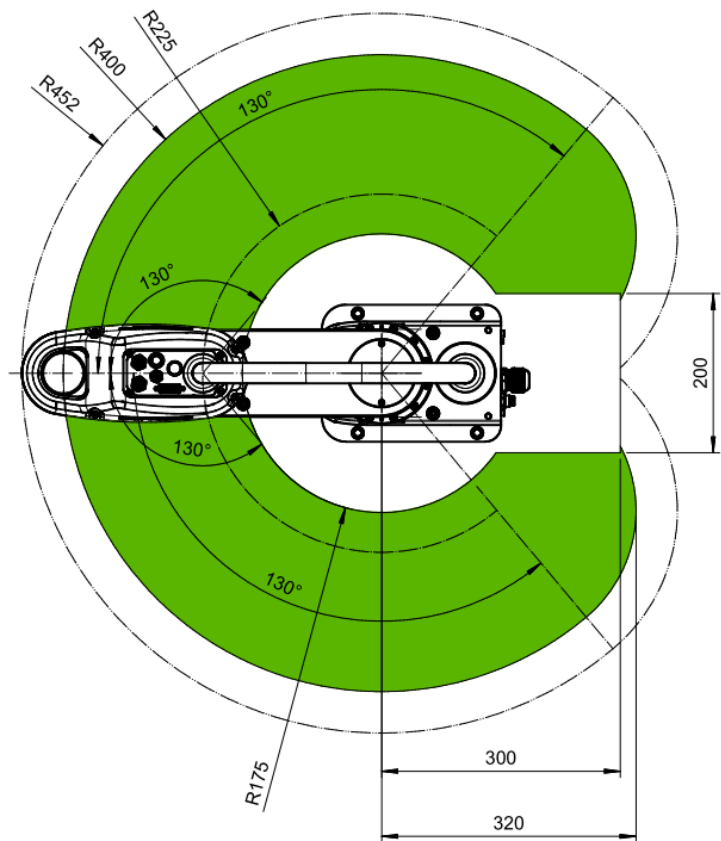
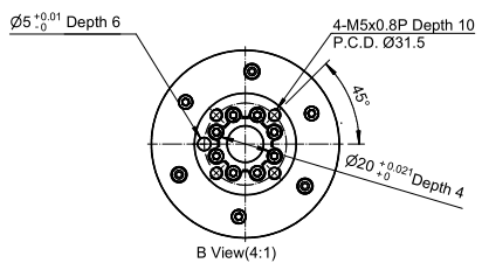

2.4.13. RS405-500-20P-LU

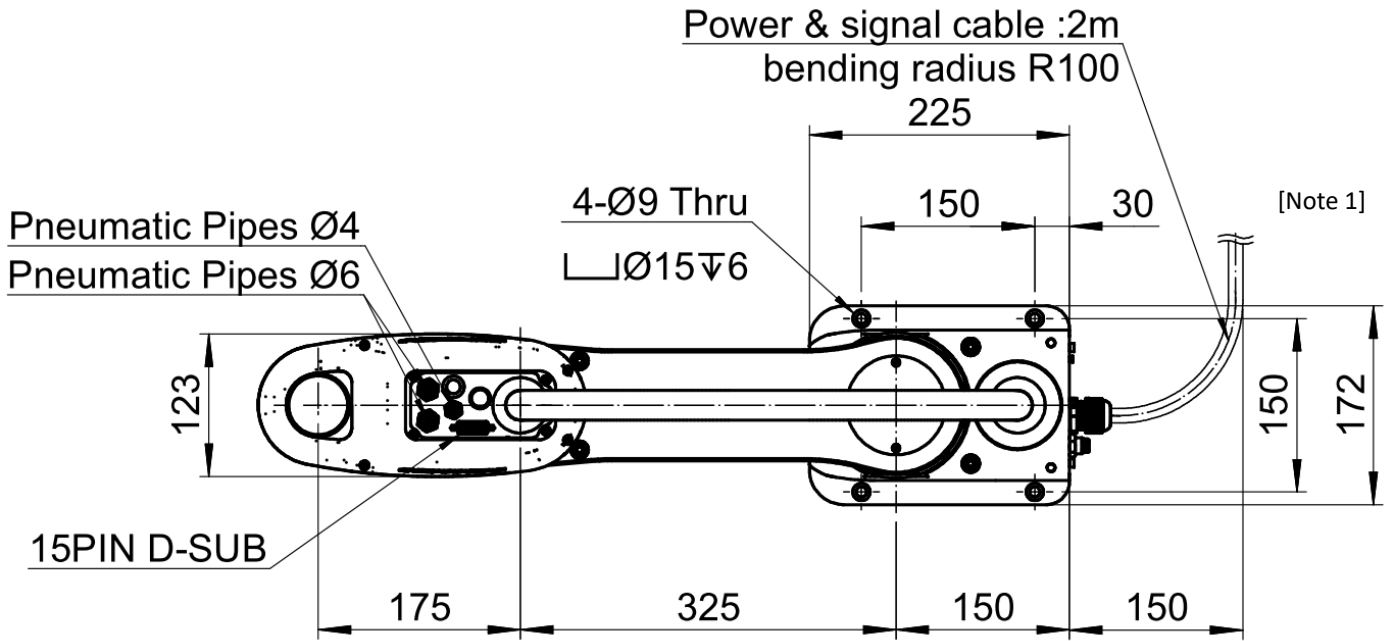

[Note 1] Cable bending radius of at least 150mm, please reserve space to deploy the cable

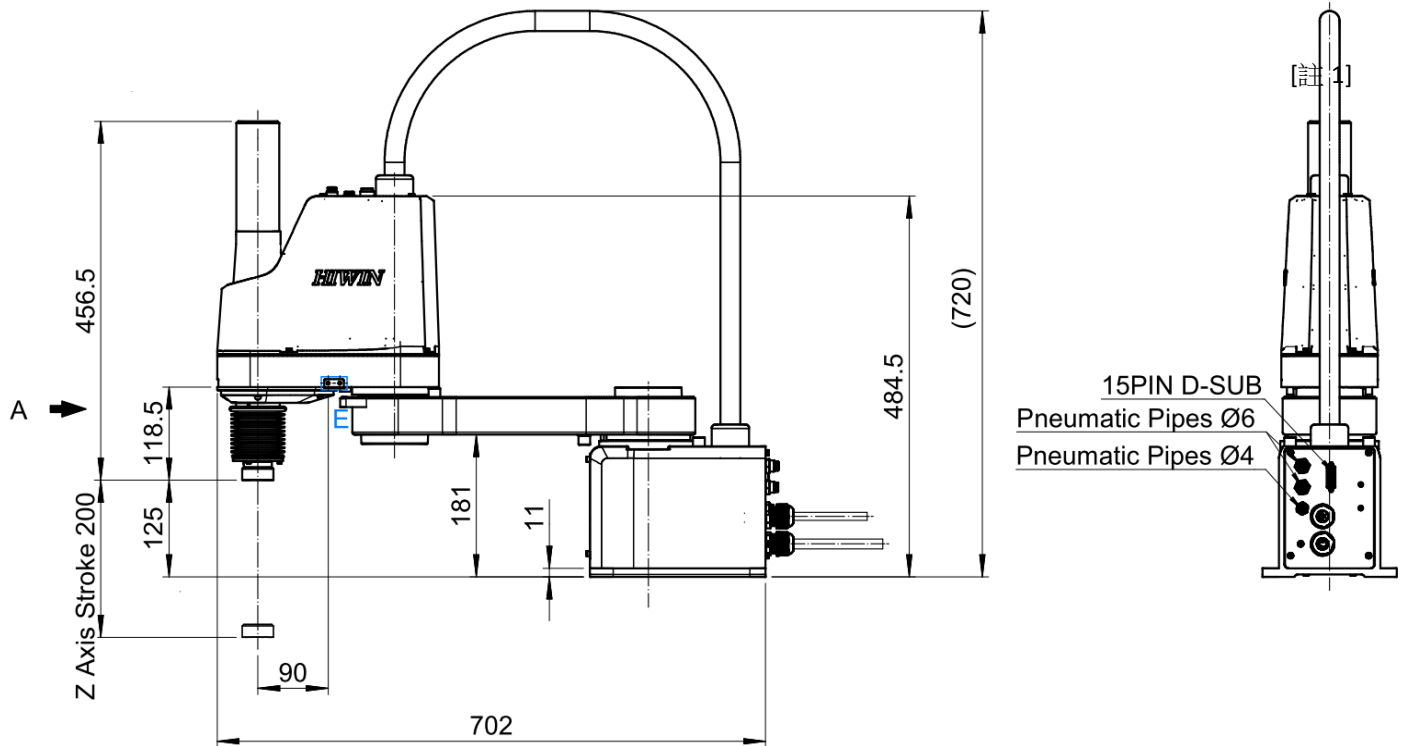

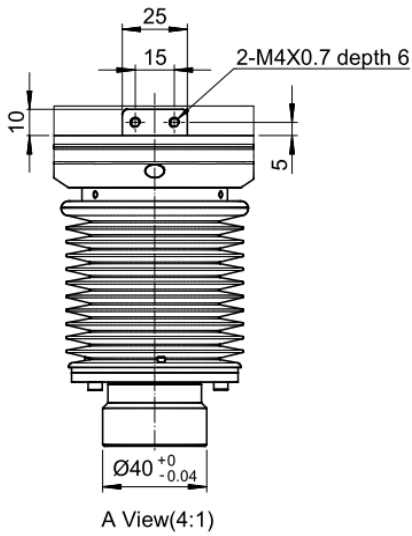
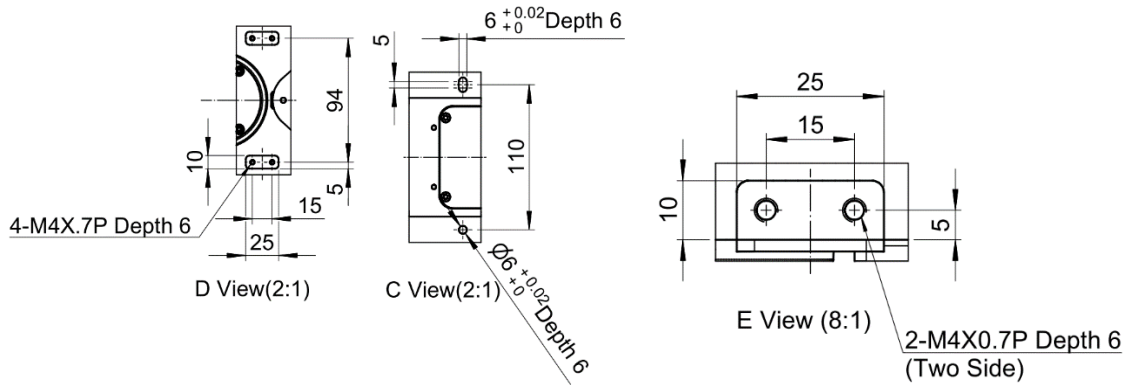
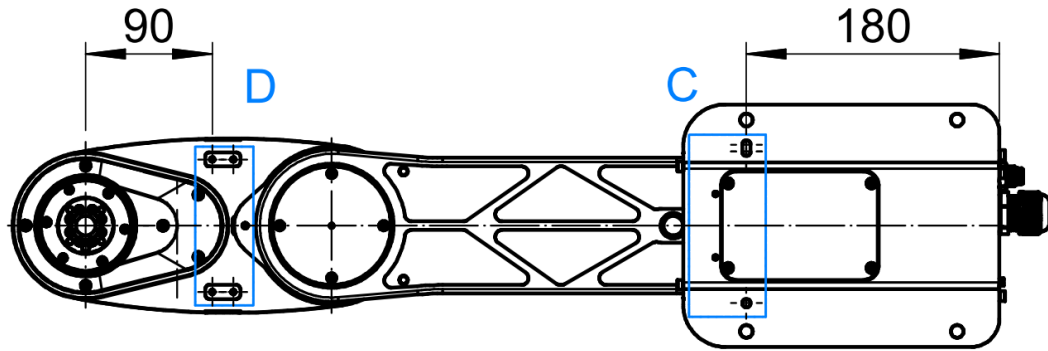

B

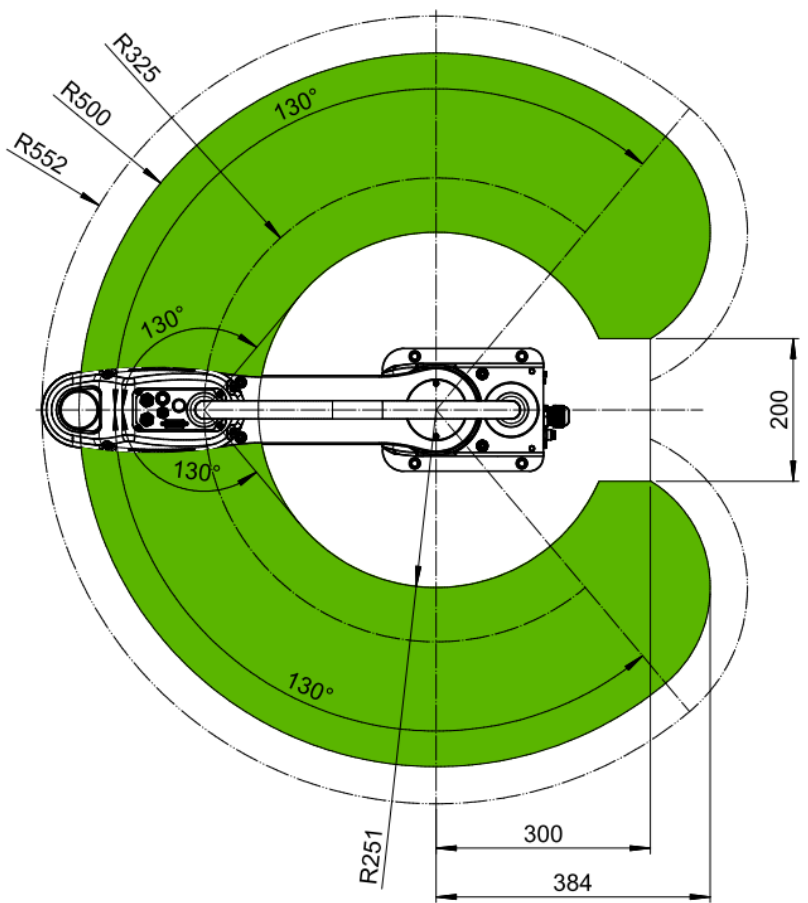
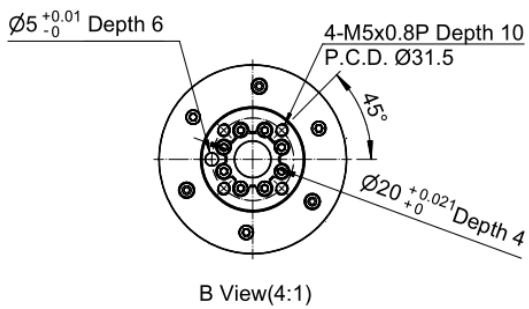

2.4.14. RS405-500-40P-LU

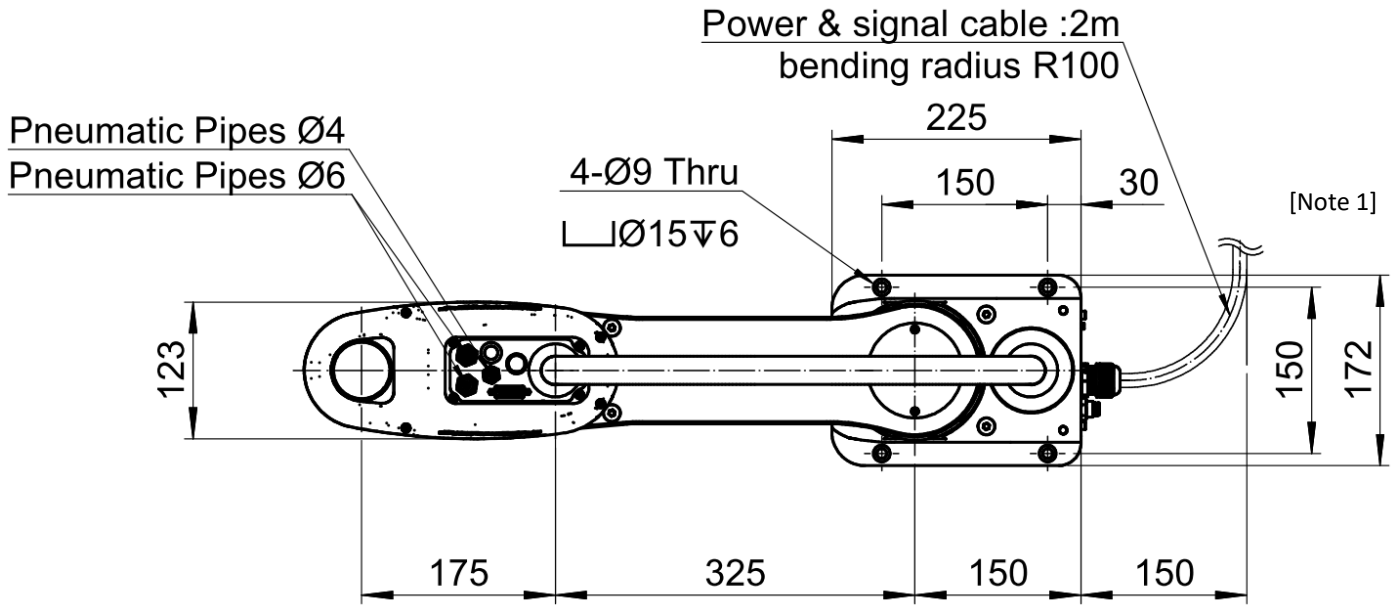

[Note 1] Cable bending radius of at least 150mm, please reserve space to deploy the cable

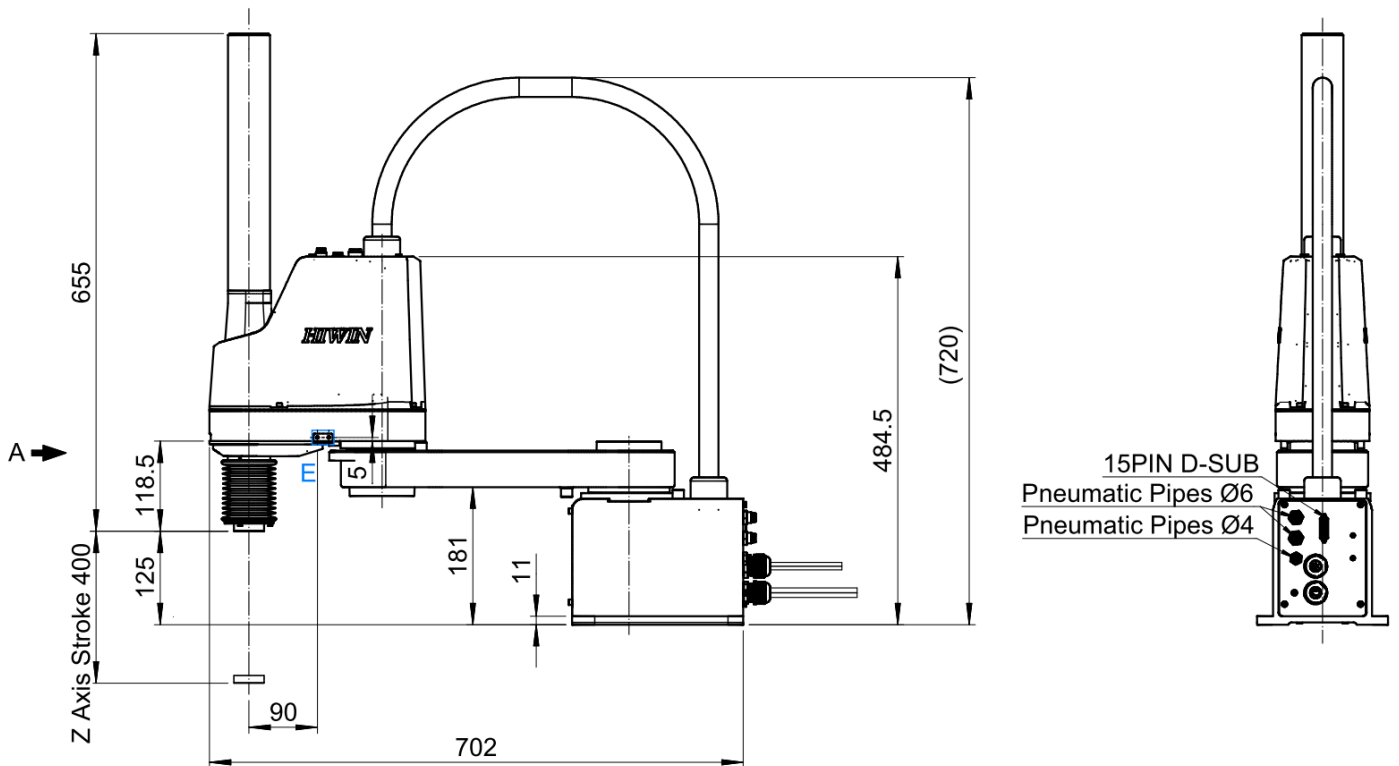

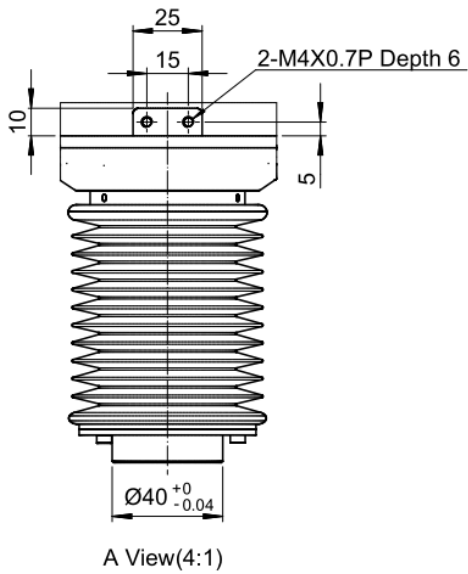
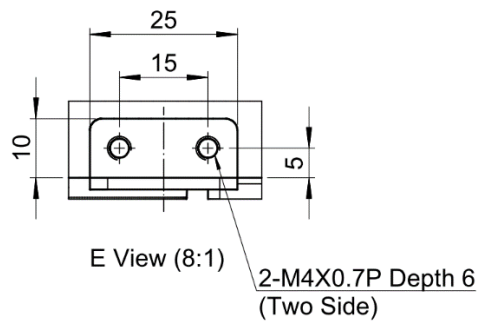
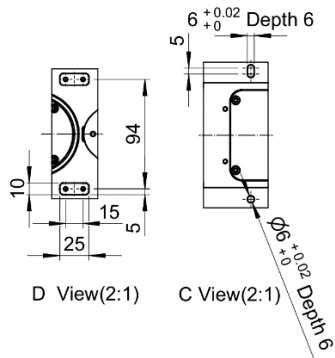
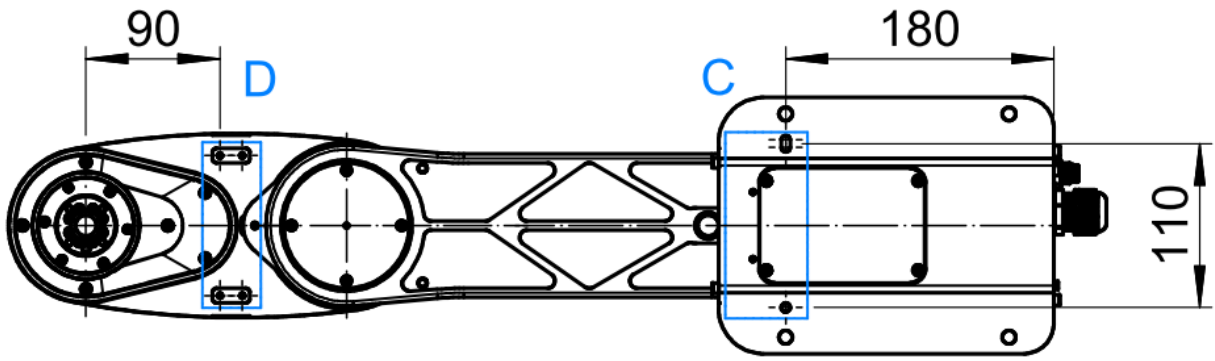

B ↑

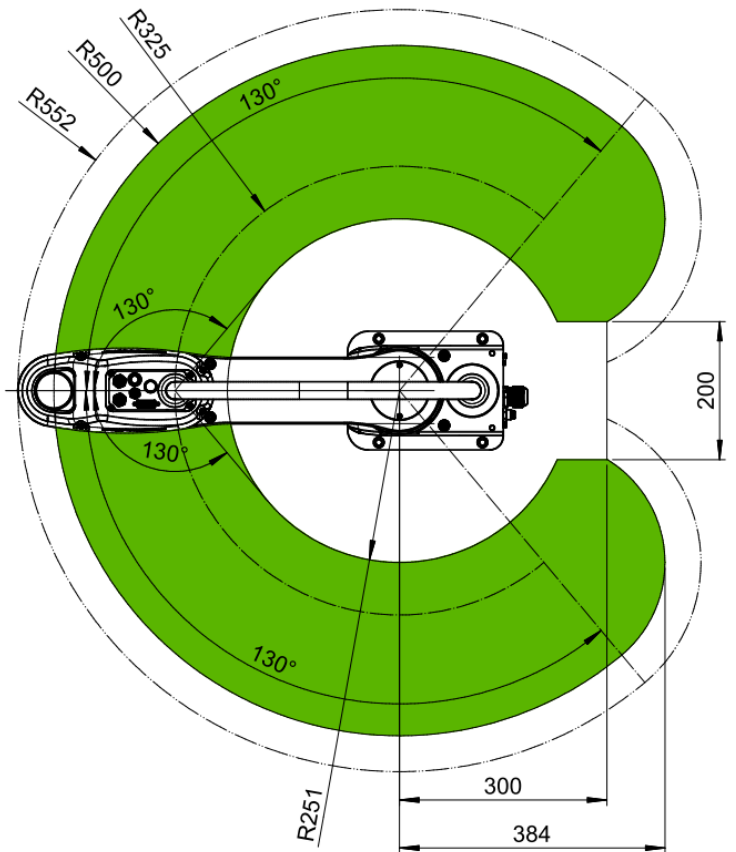
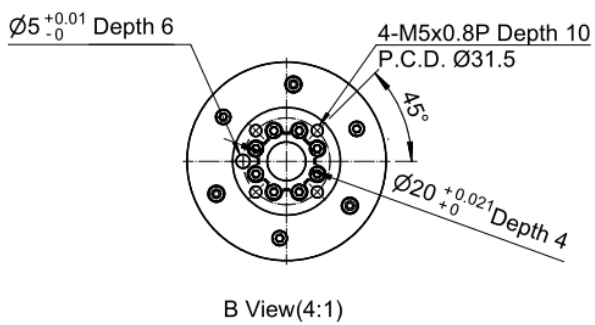

2.4.15. RS410-600-20P-LU

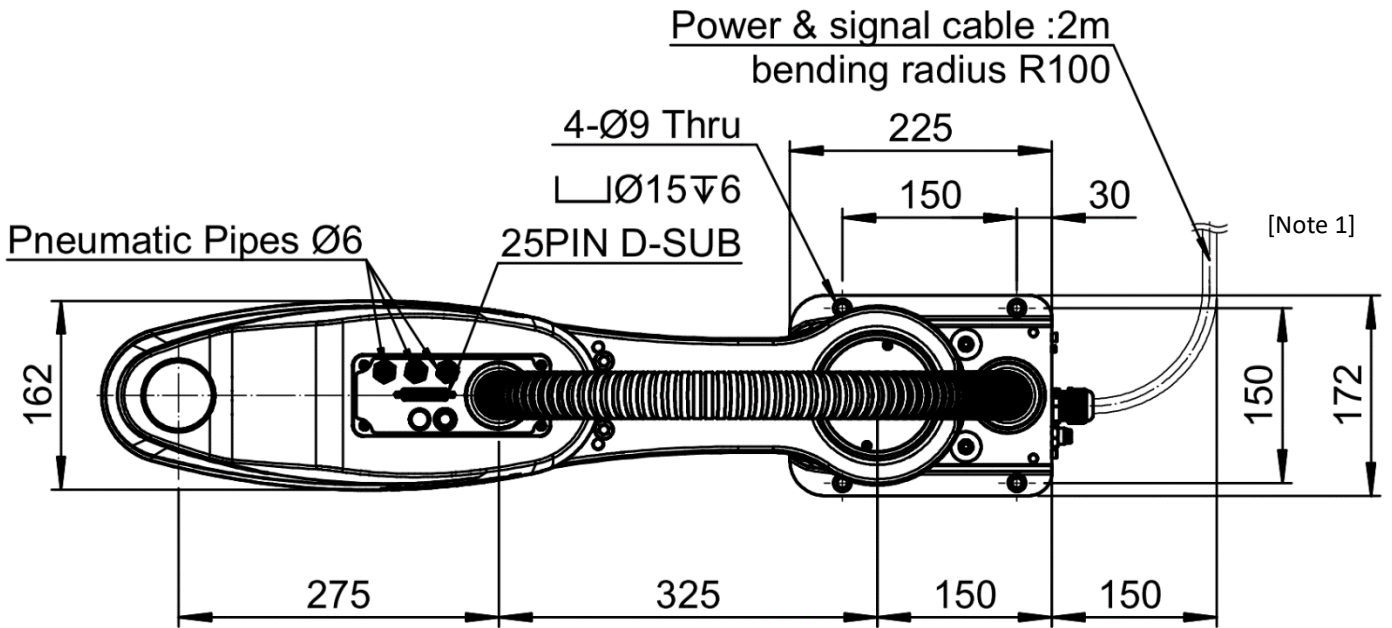

[Note 1] Cable bending radius of at least 150mm, please reserve space to deploy the cable

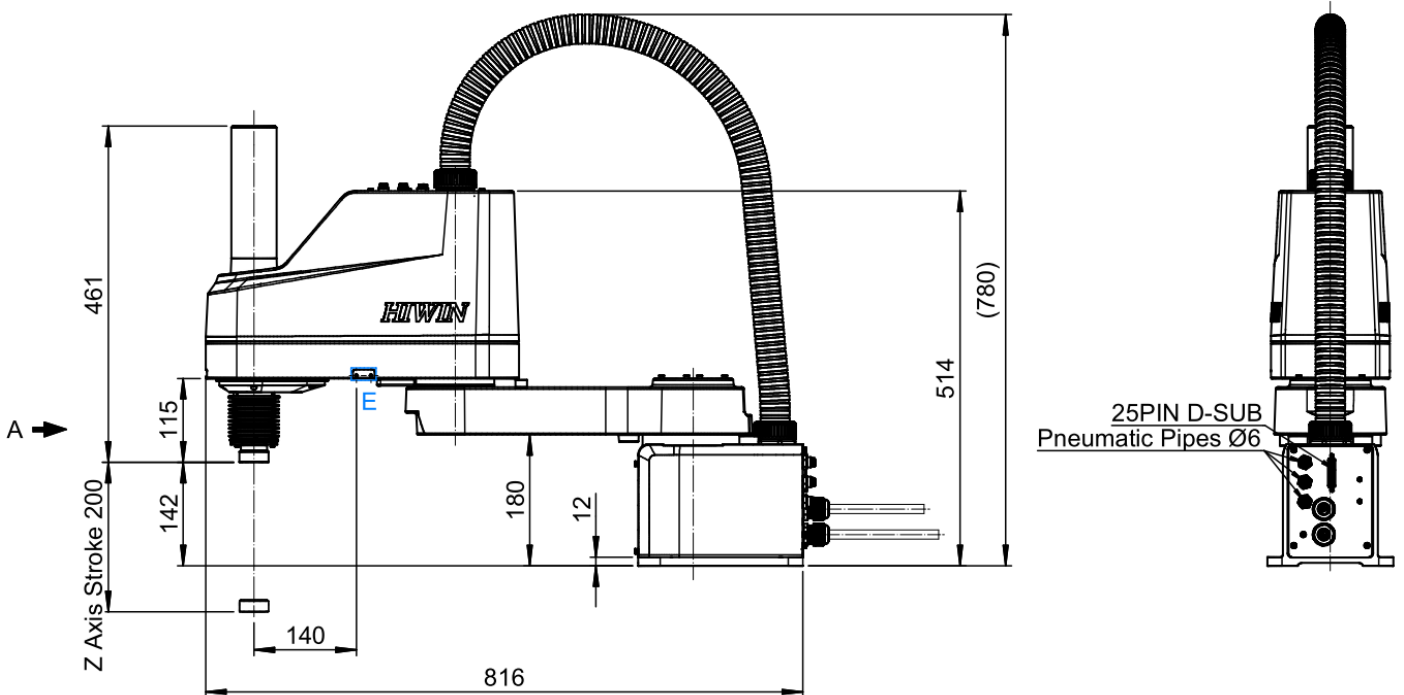

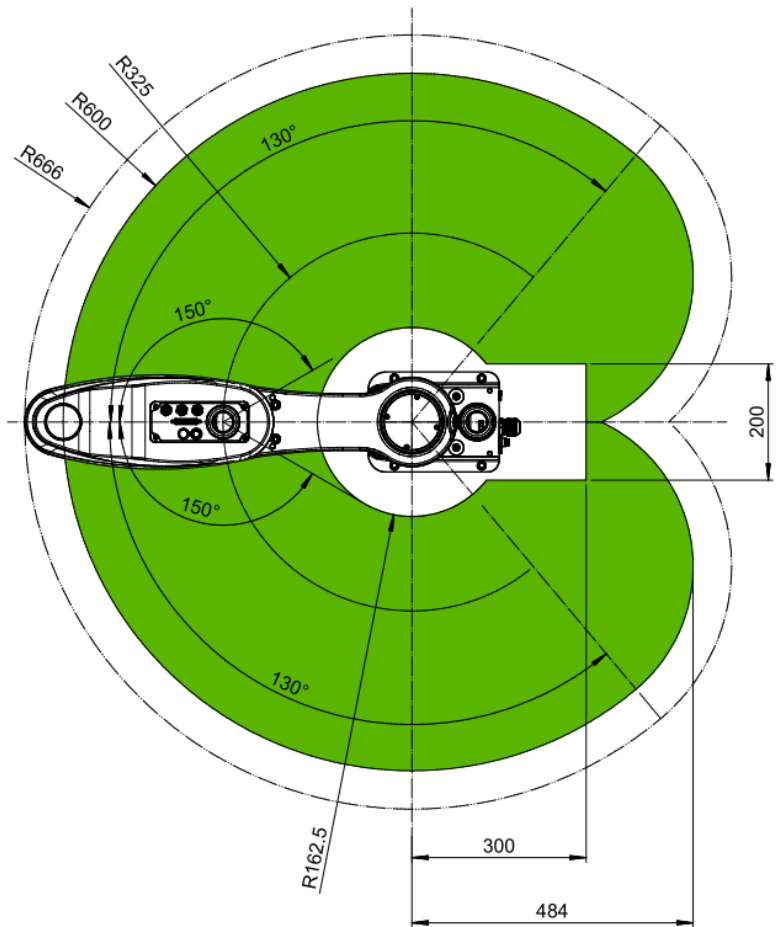
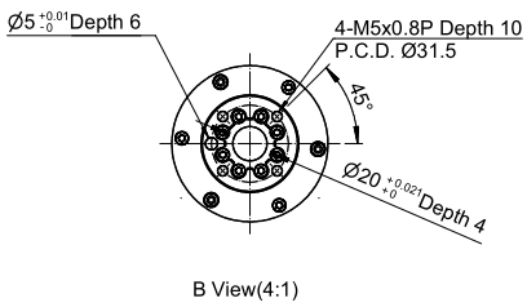
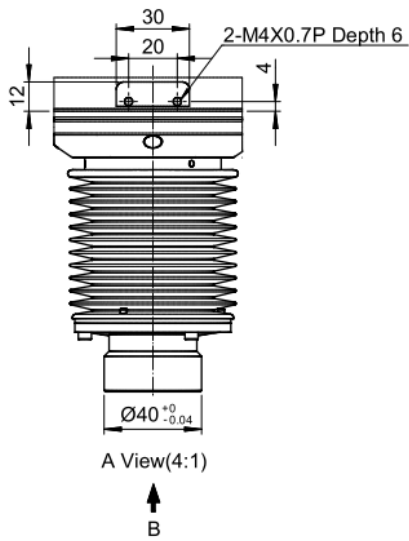
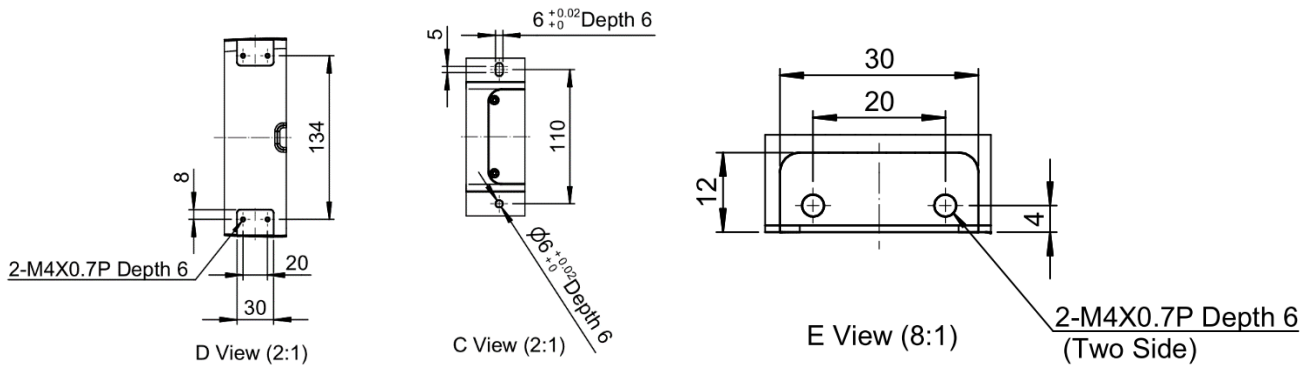
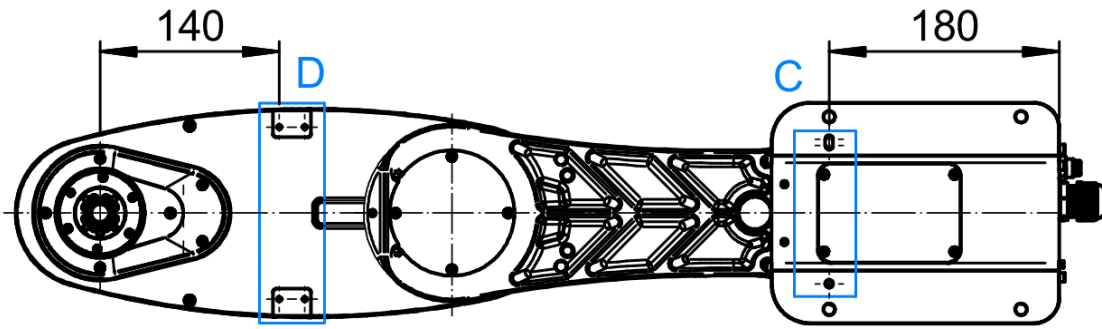

2.4.16. RS410-600-40P-LU

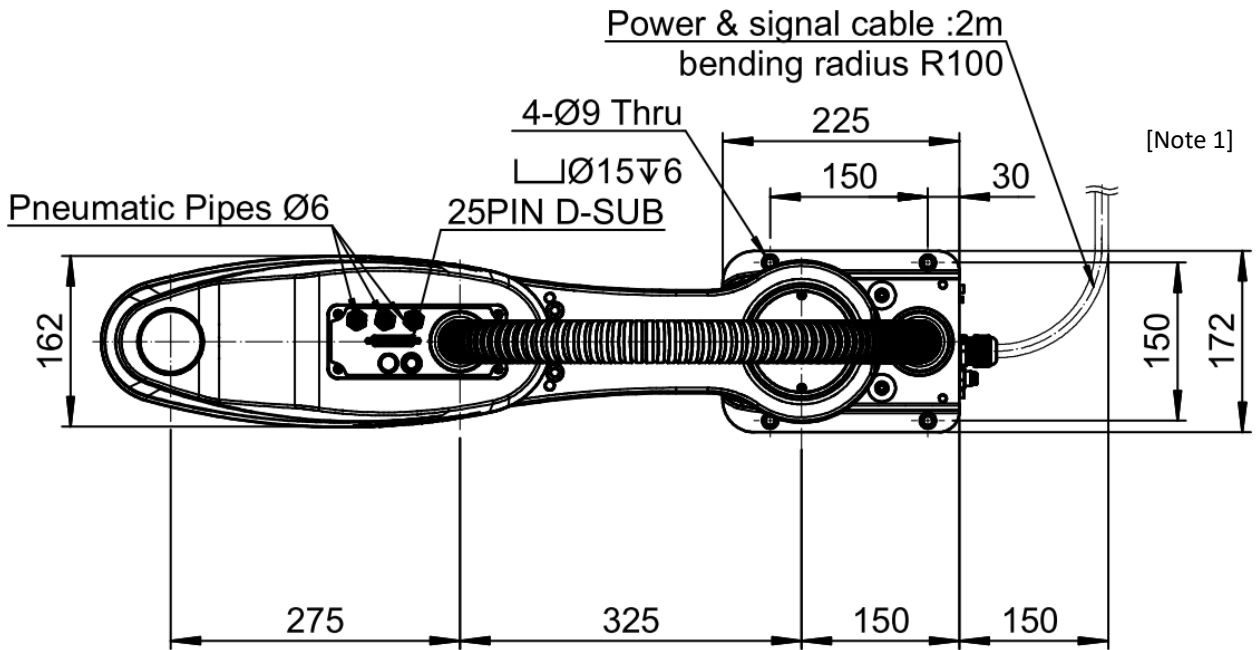

[Note 1] Cable bending radius of at least 150mm, please reserve space to deploy the cable

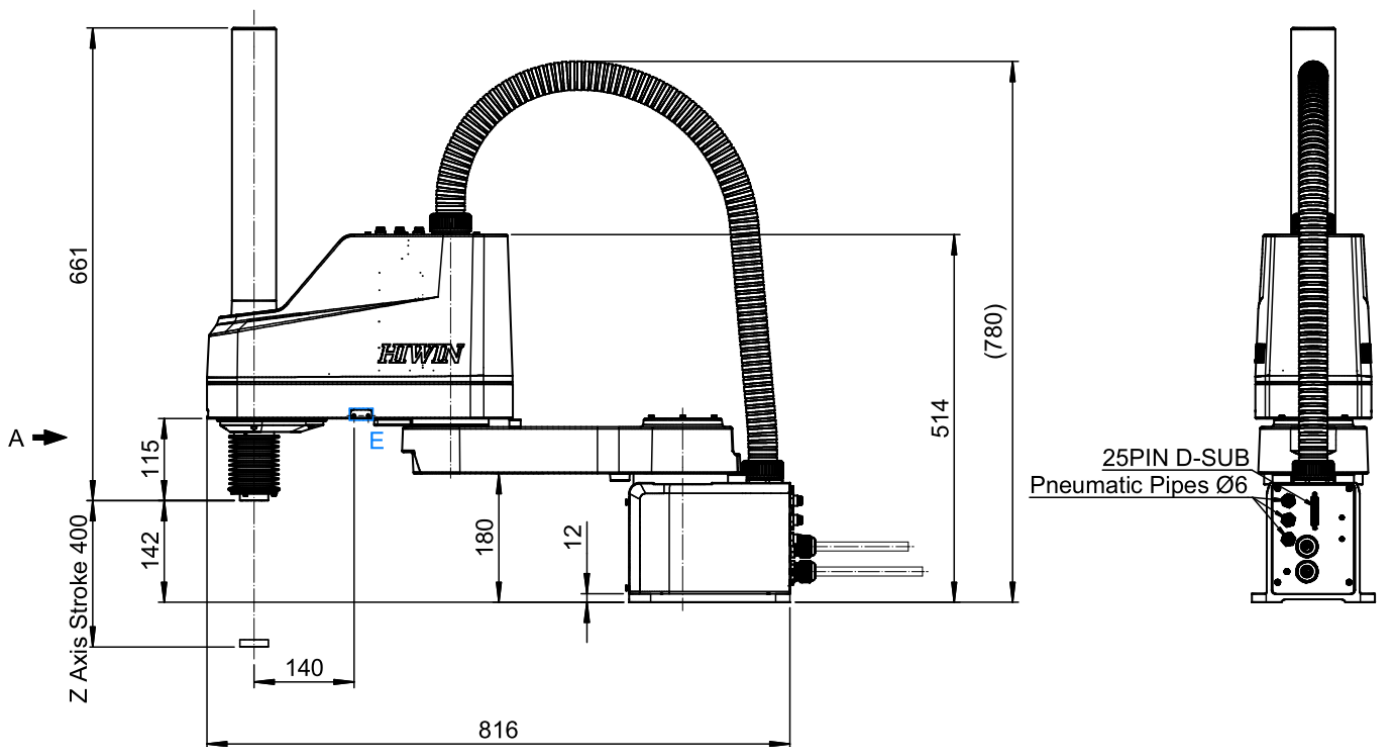

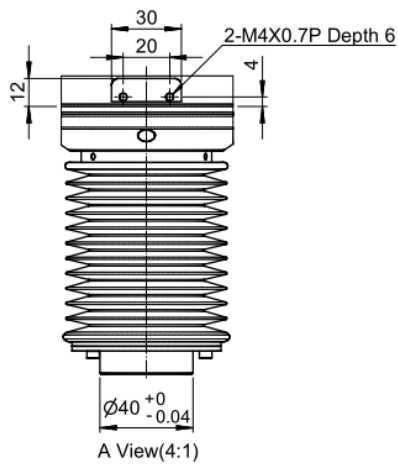
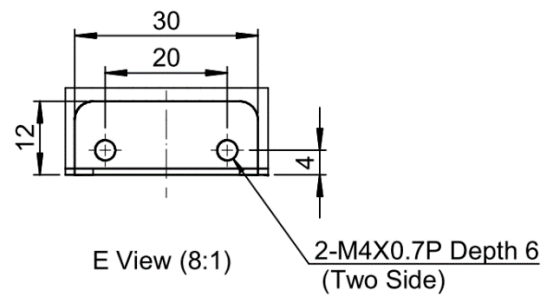
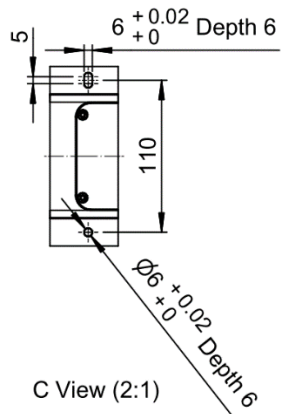
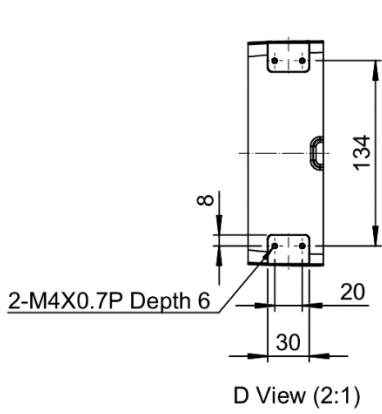
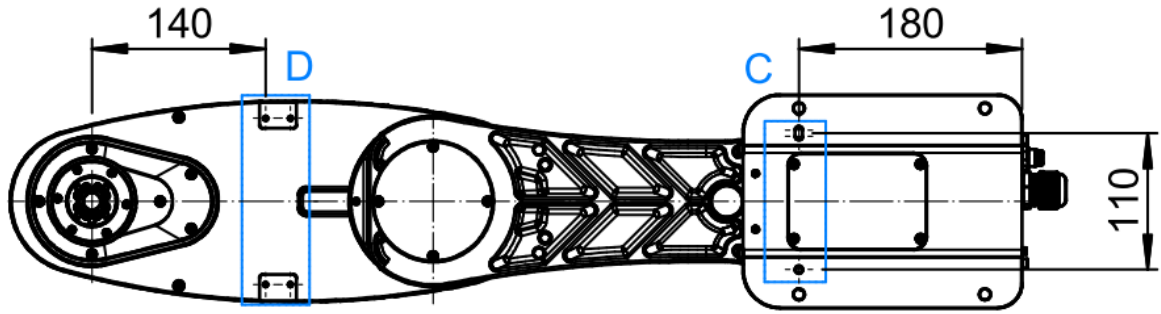

B

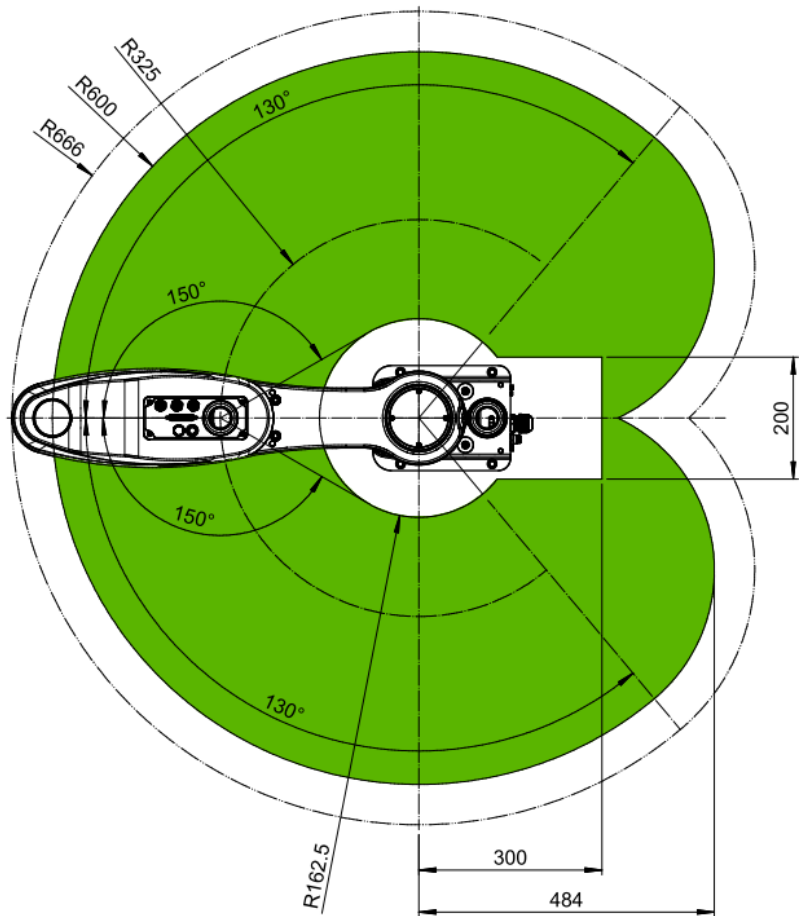
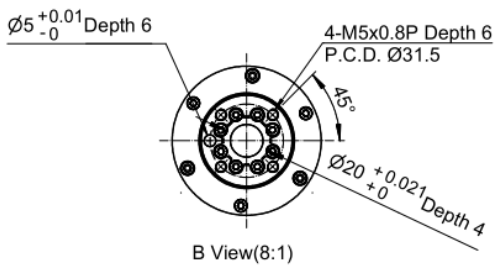

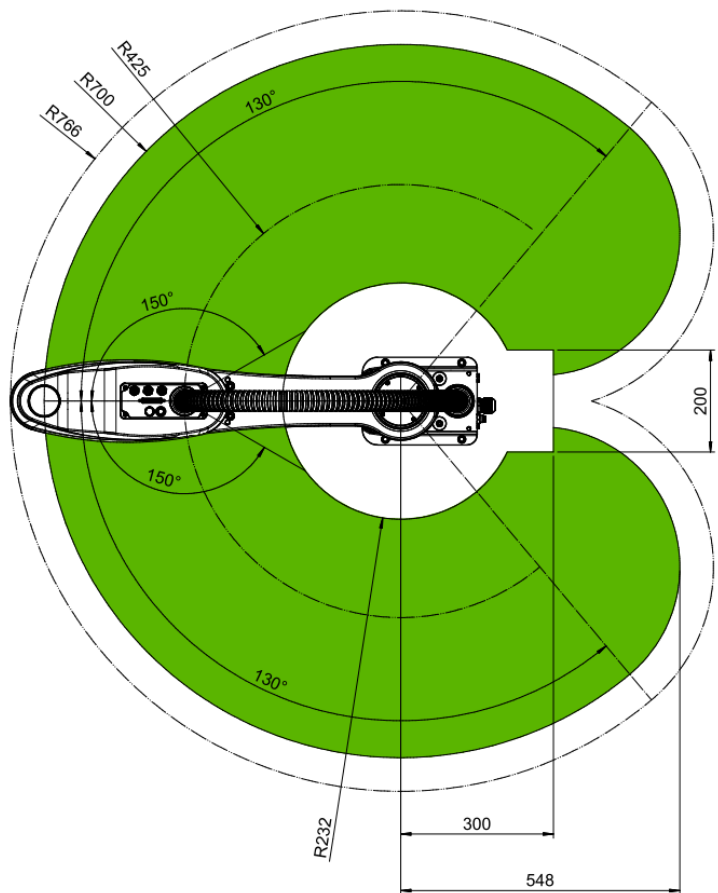
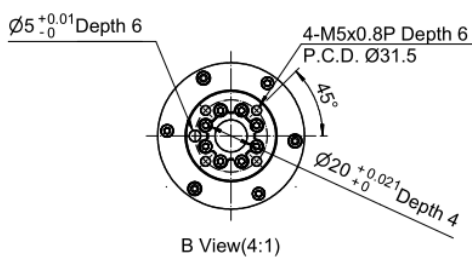
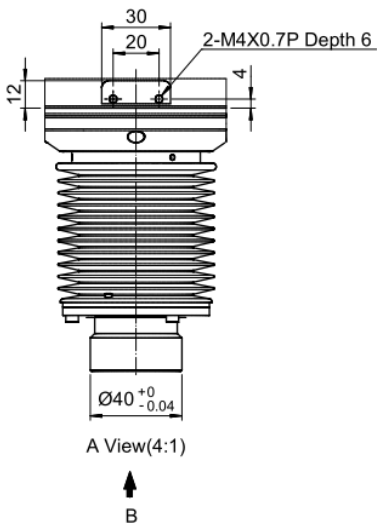
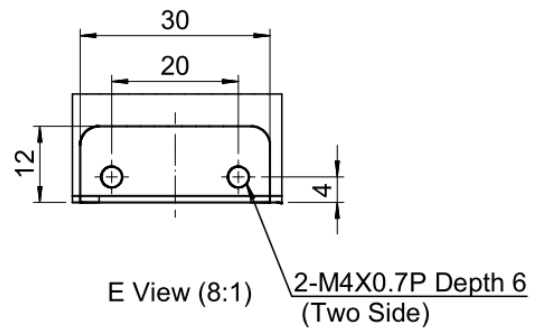
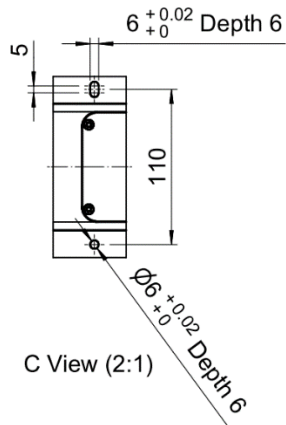
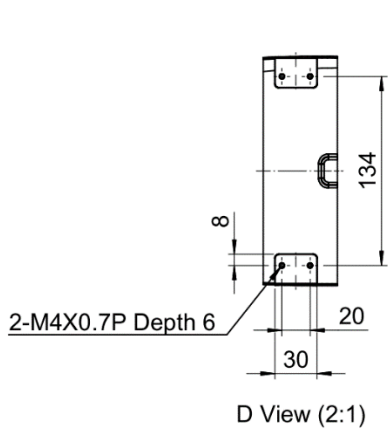
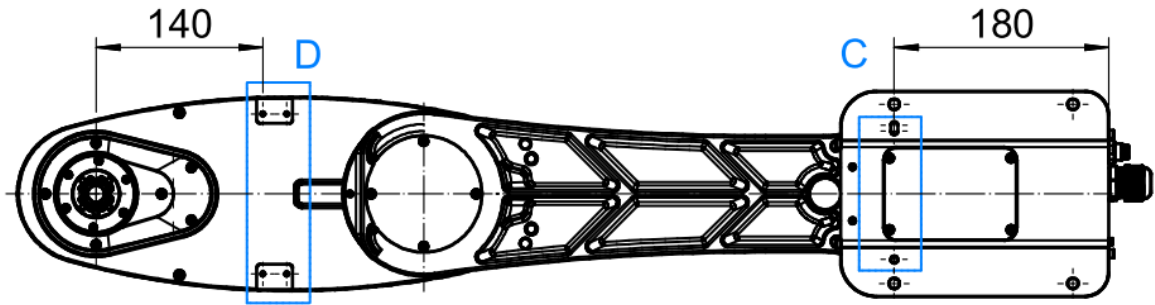

2.4.18. RS410-700-40P-LU

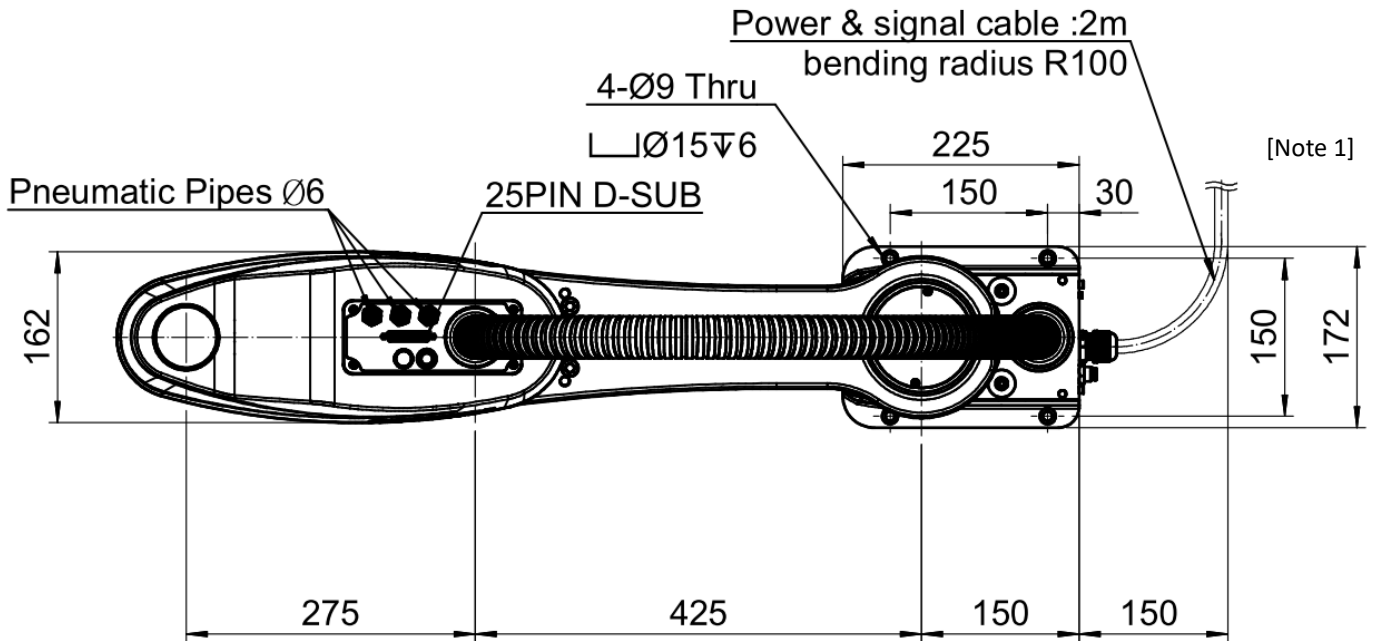

[Note 1] Cable bending radius of at least 150mm, please reserve space to deploy the cable

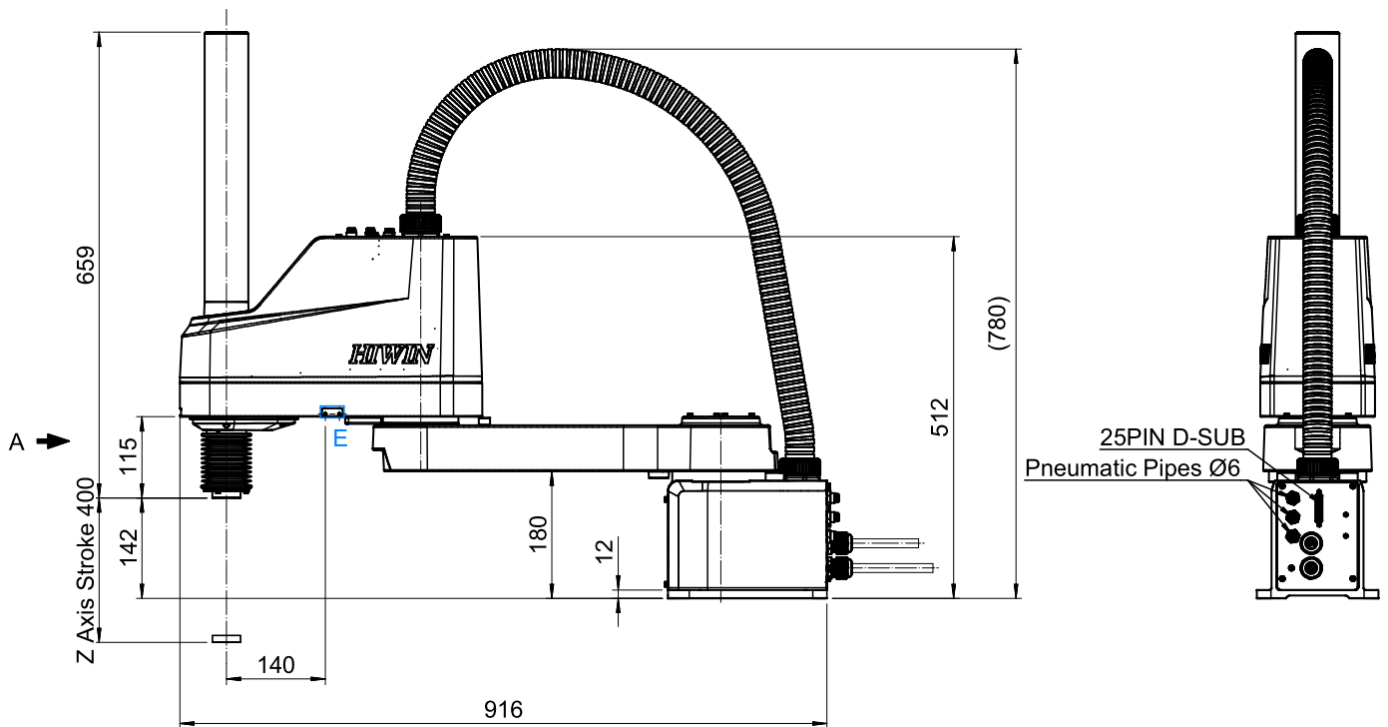

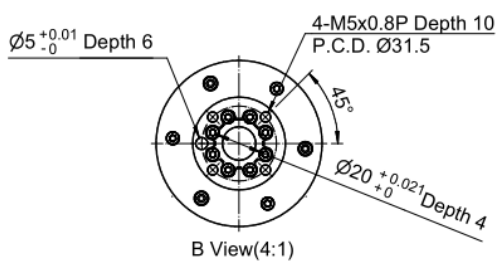
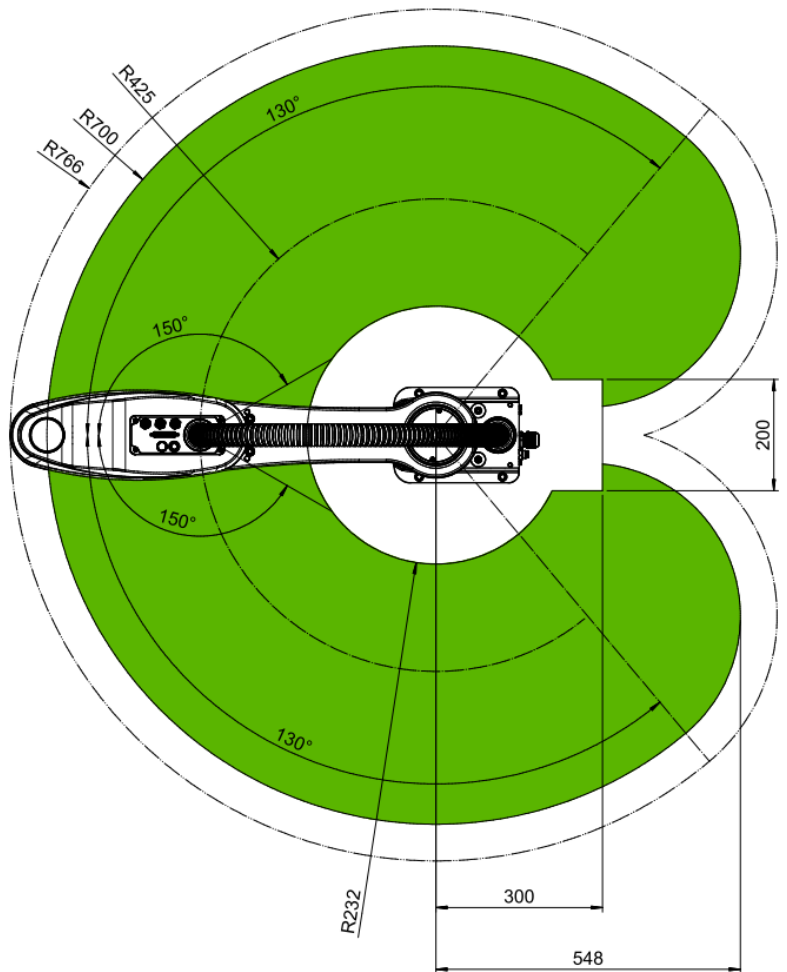
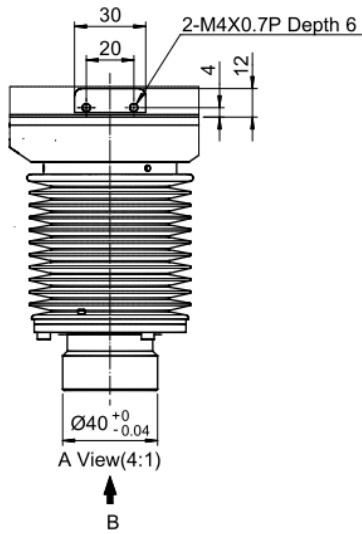
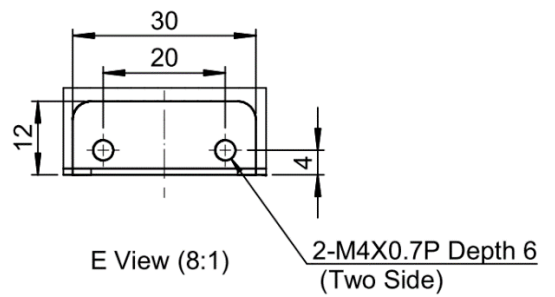
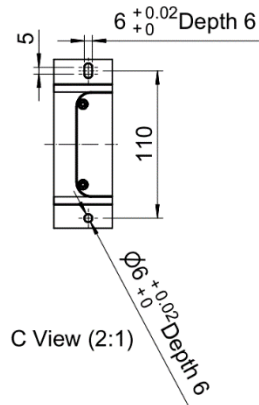
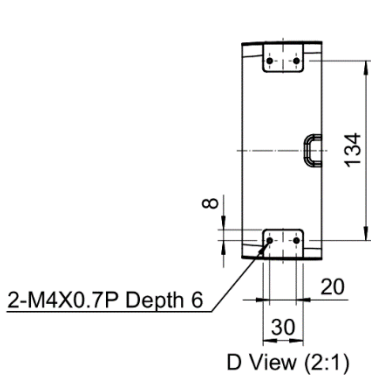
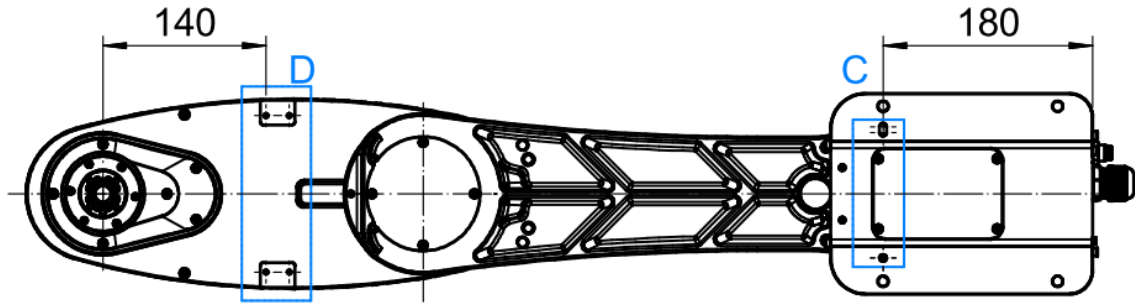

2.4.19. RS410-800-20P-LU

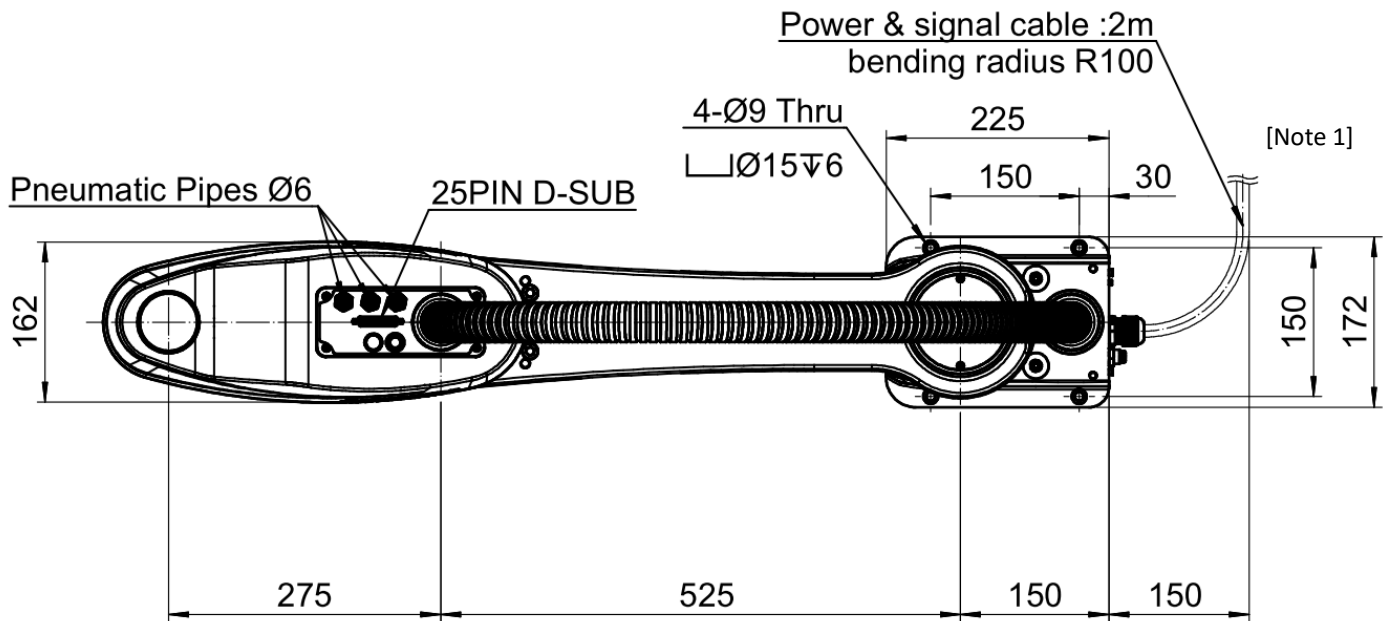

[Note 1] Cable bending radius of at least 150mm, please reserve space to deploy the cable

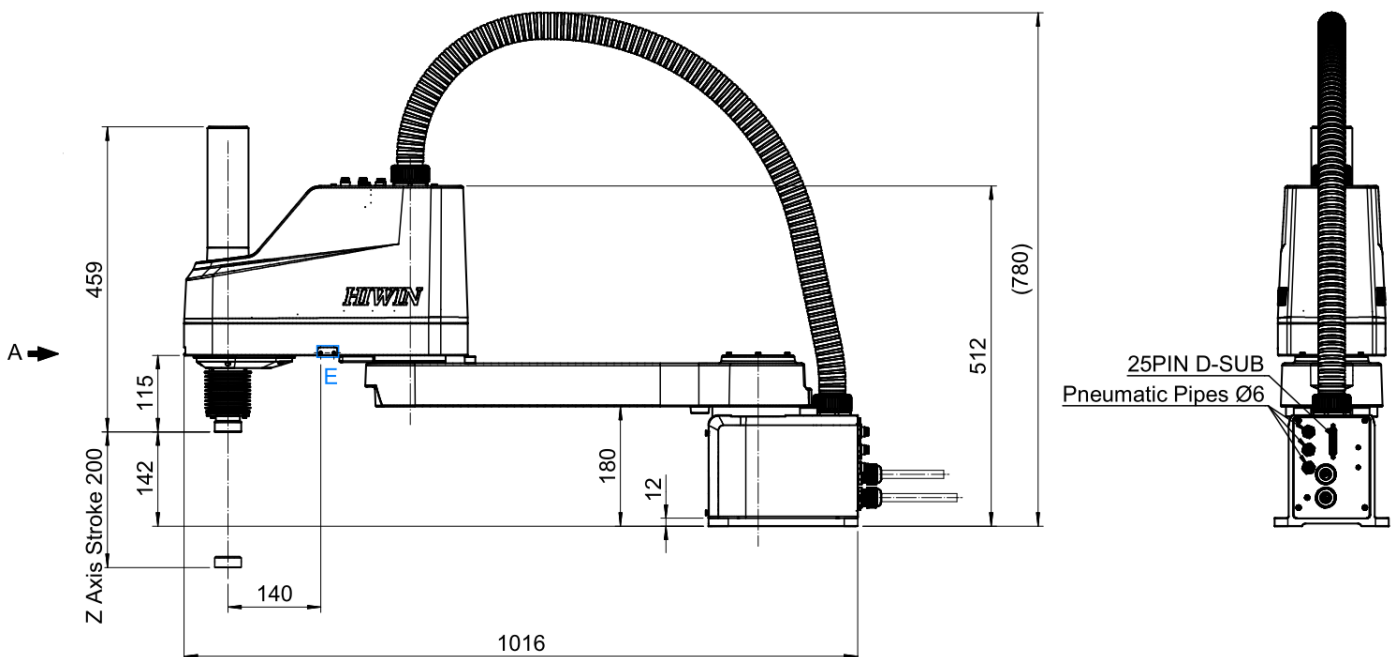

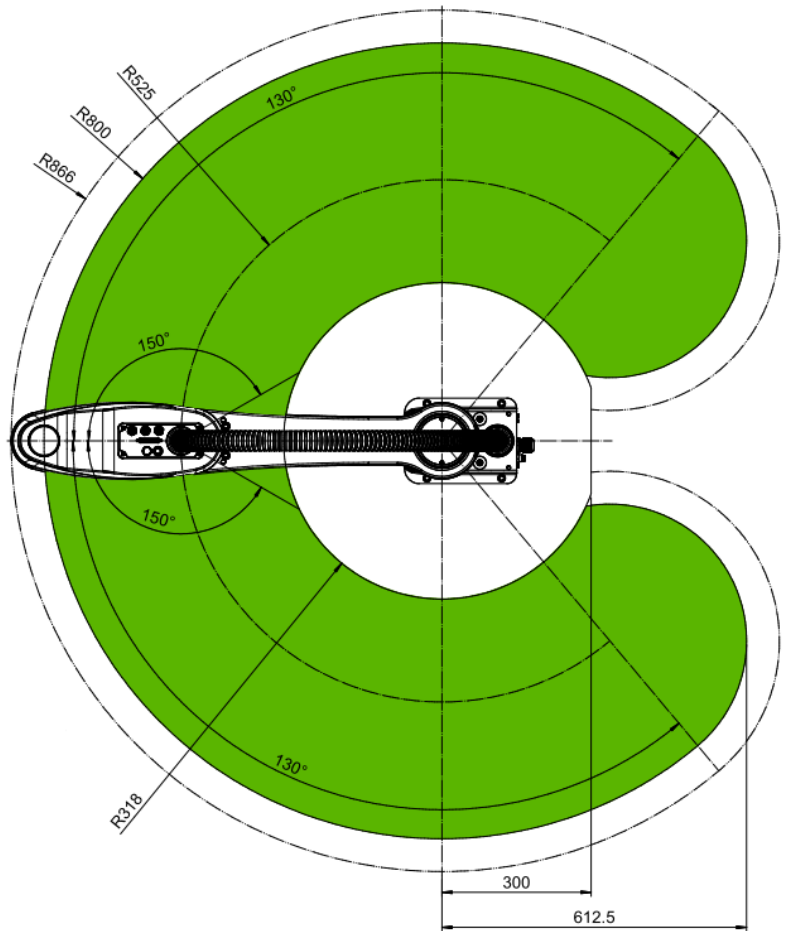
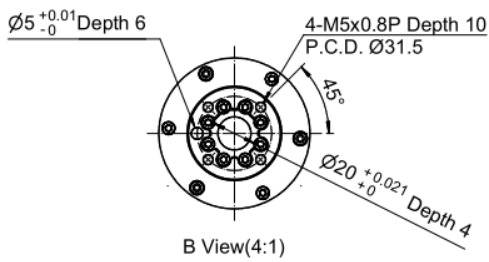
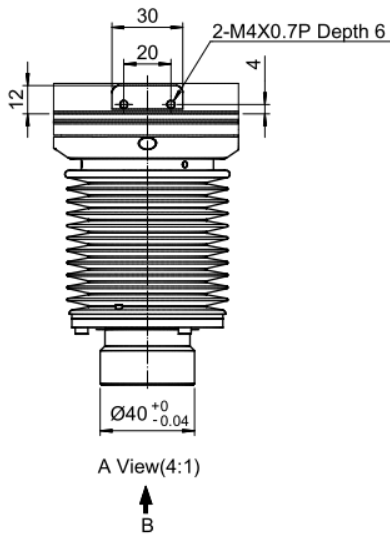
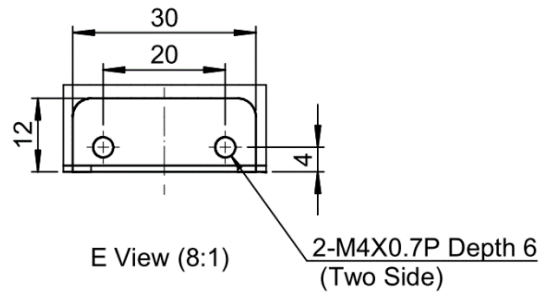
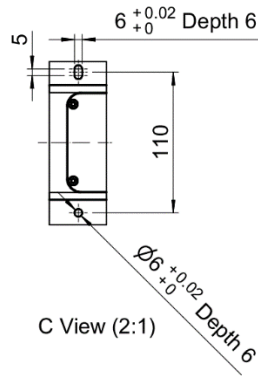
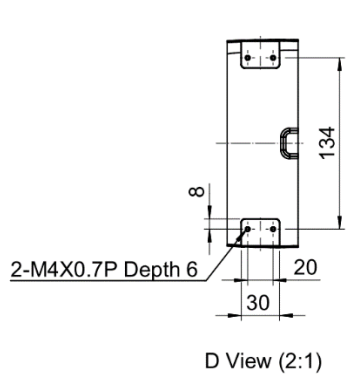
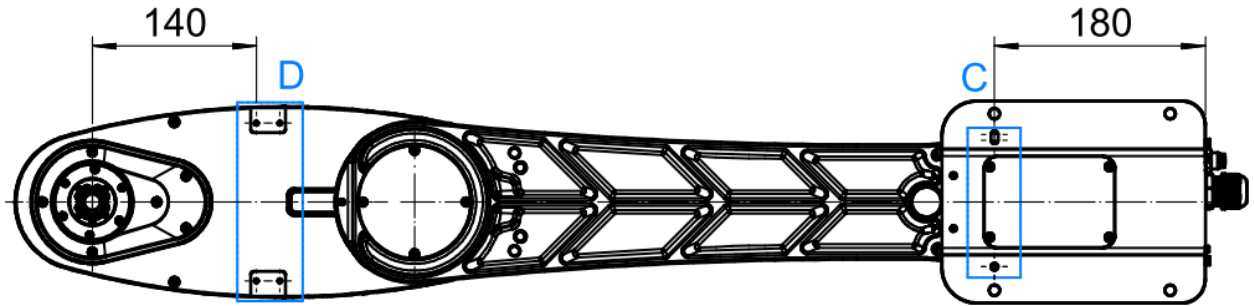

2.4.20. RS410-800-40P-LU

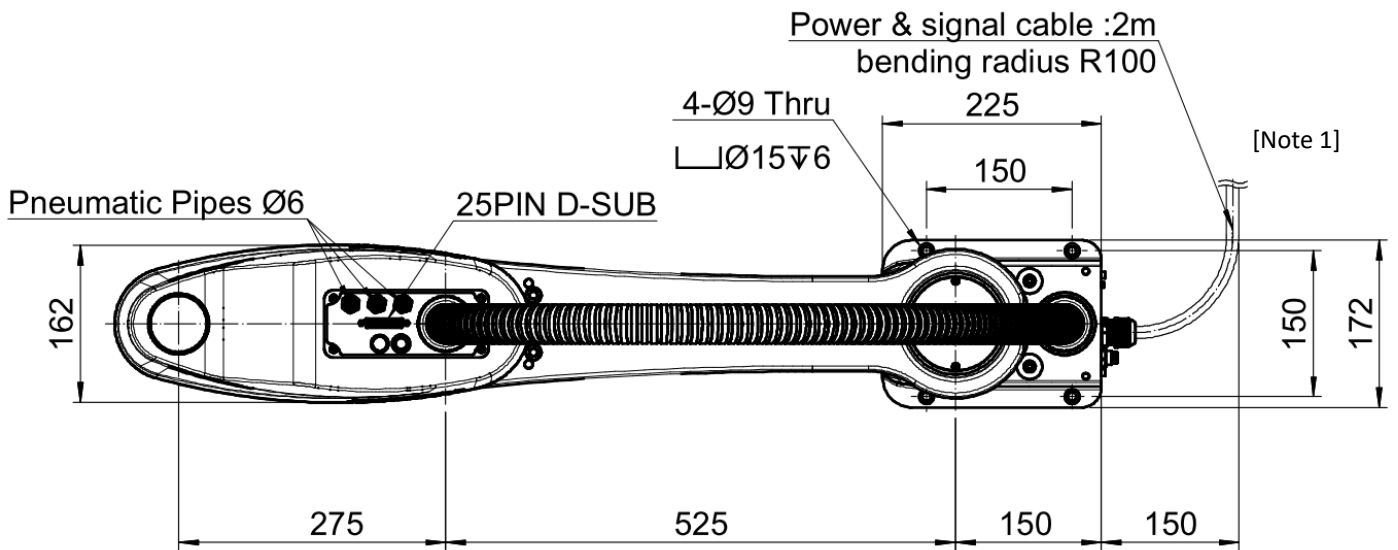

[Note 1] Cable bending radius of at least 150mm, please reserve space to deploy the cable

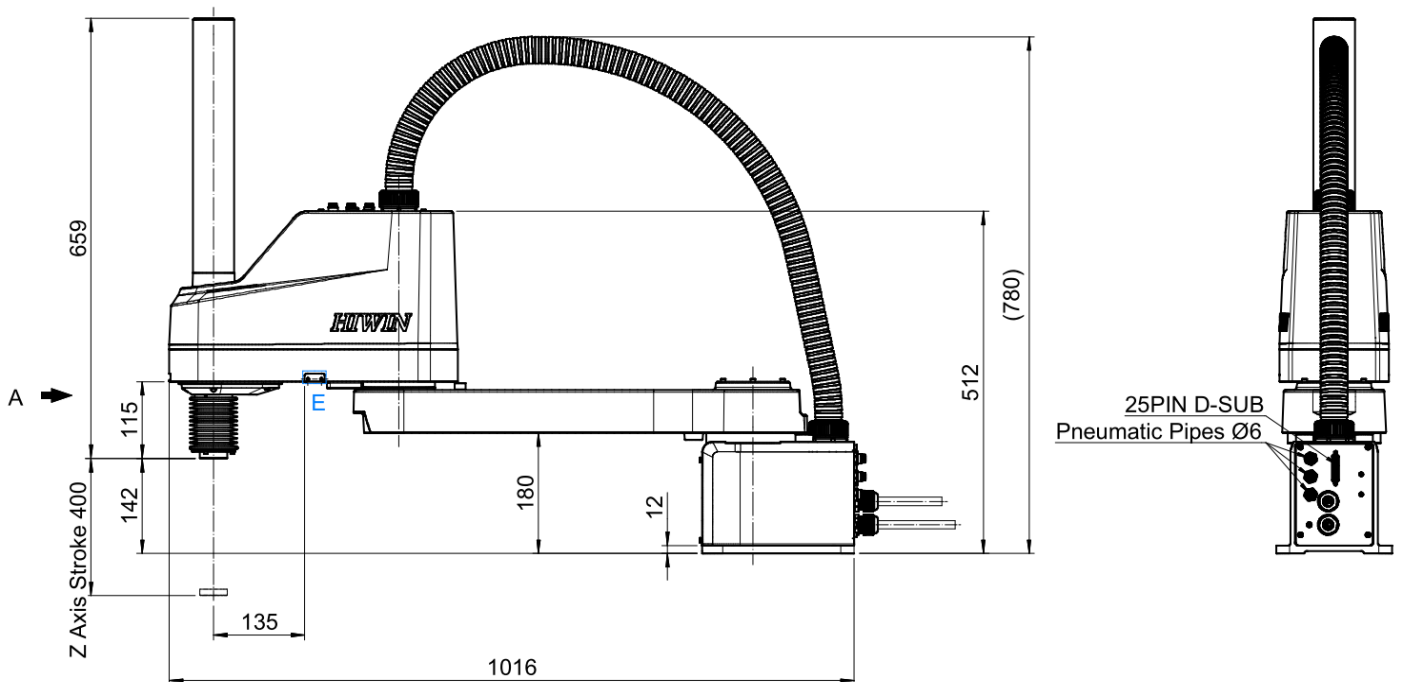

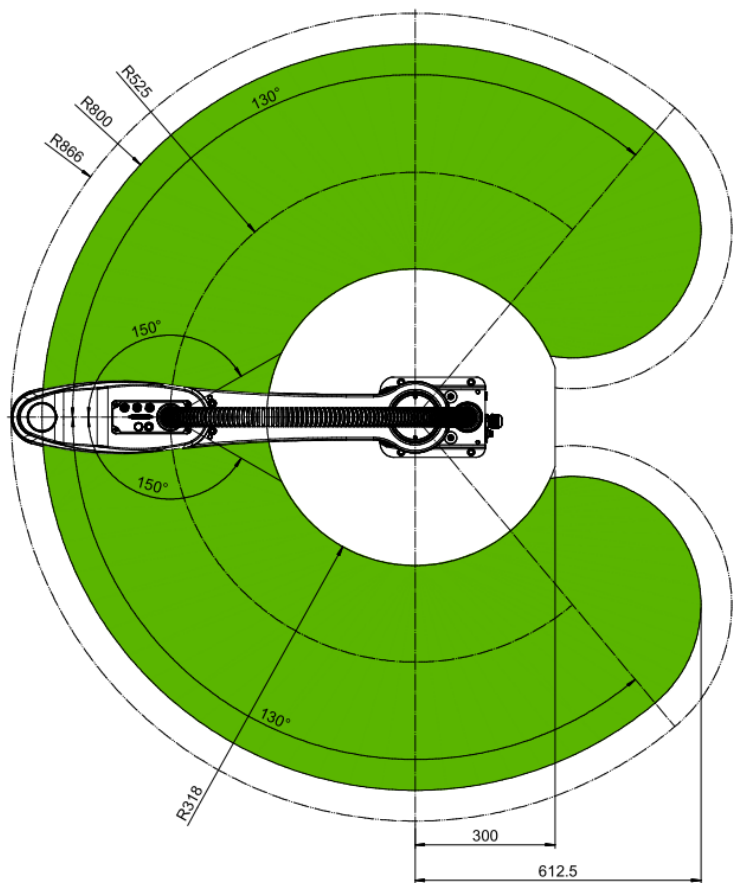
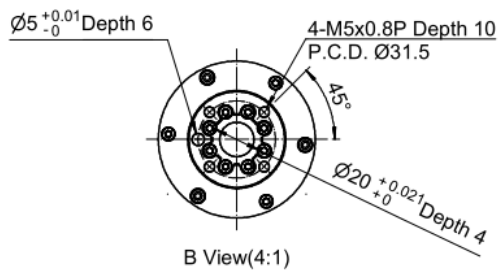
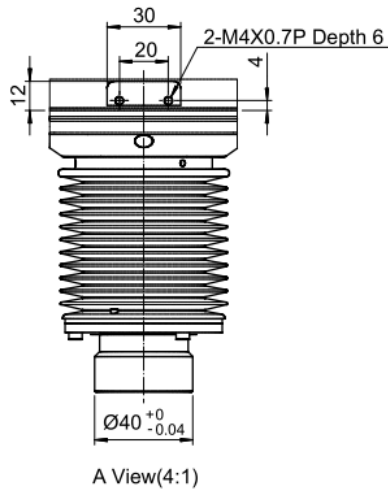
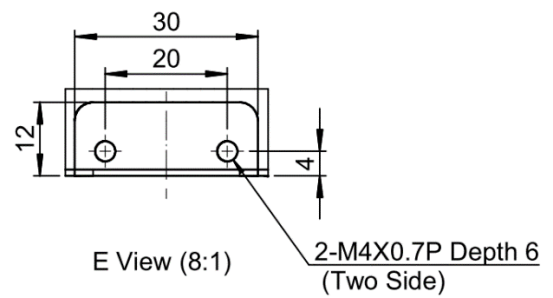
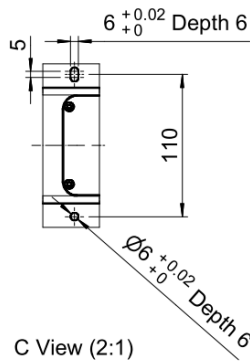
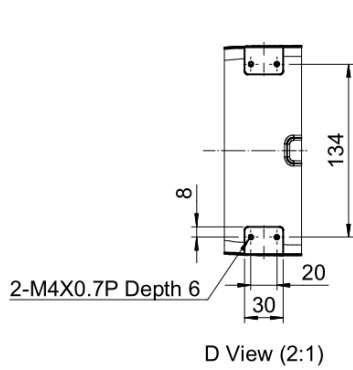
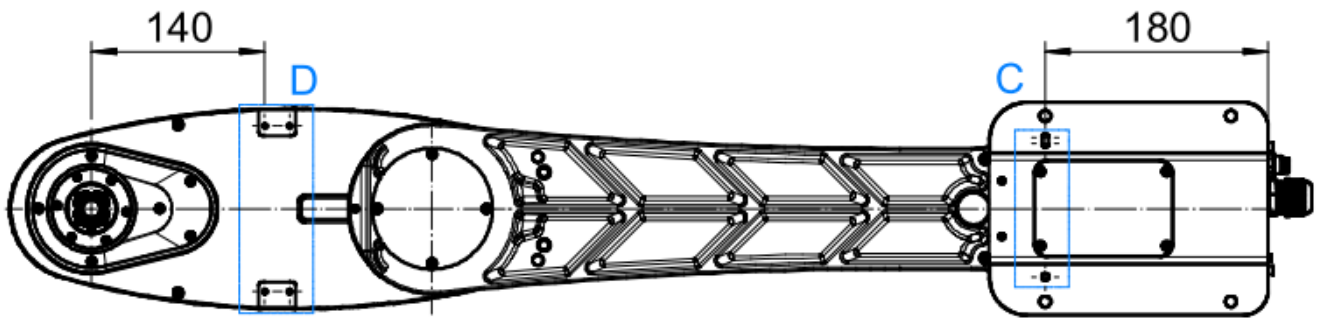

2.5. Mechanical shaft hardware limit

The mechanical stop of each arm of the robot arm is installed on J1, J2 and J3 to limit the range of motion of each axis to the minimum.

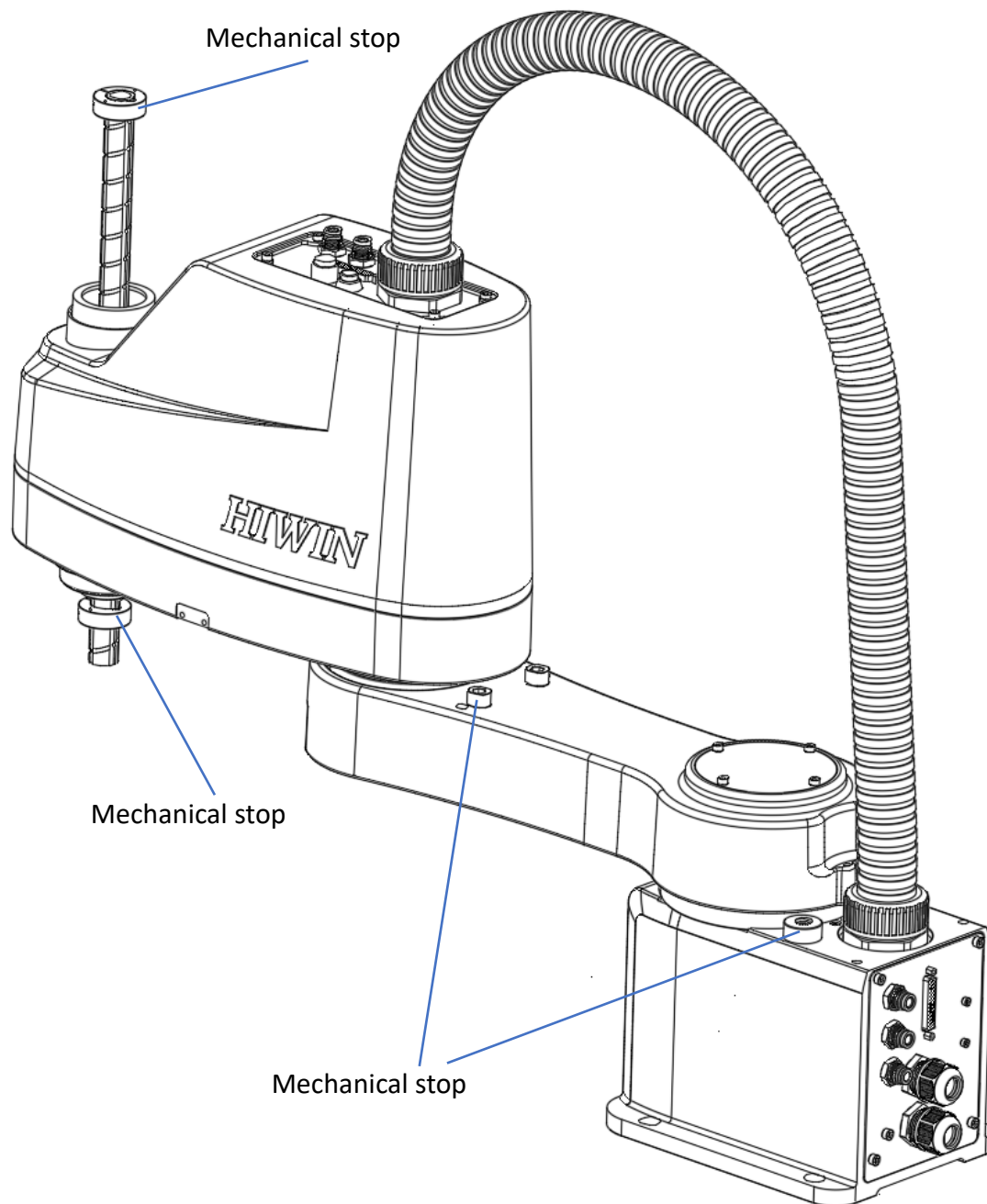

3. Device Installation

3.1. End effector installation

When setting up the end effector, be sure to observe the following.

1. Do not remove or change any mechanical stops on your arm.
2. When installing the end effector on the ball spline, use an end flange at the lower end of the ball spline 30mm. And install the end effector with bolts to fix on the end flange.
3. When installing the end effector, please pay attention to whether the weight, static torque and moment of inertia are within the arm specification. For the calculation method of static moment and moment of inertia.

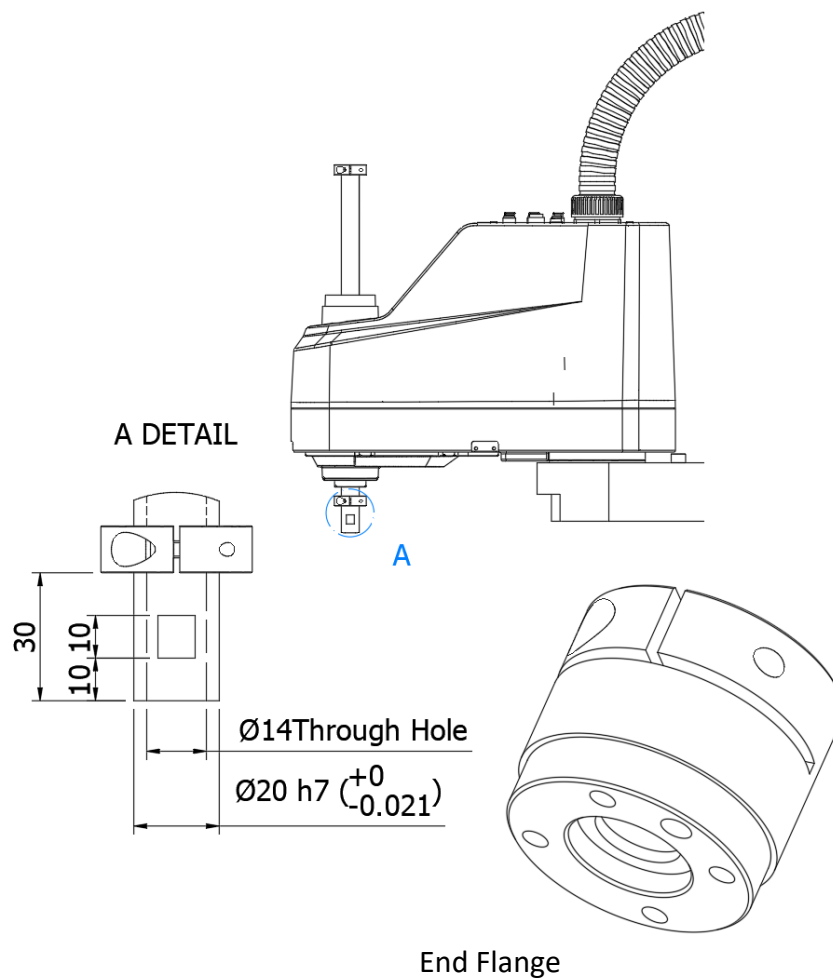

CAUTION

❖ If you have any doubts about the weight, static torque, and moment of inertia evaluation, please contact our company or dealer.

3.1.1. End Flange

The end flange(optional) is mounted on the ball spline and can be used to install various end effectors.

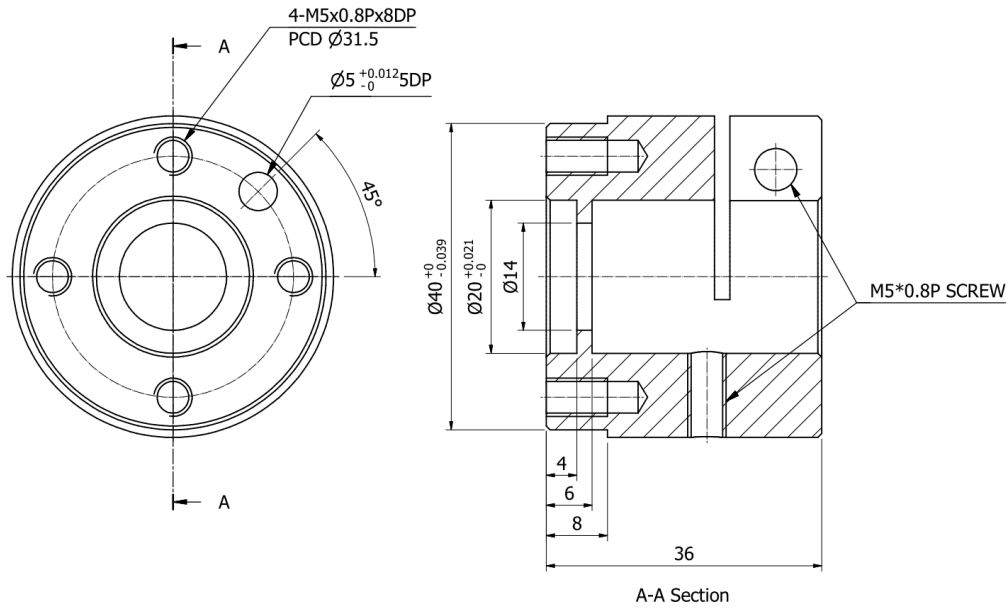

Installation steps:

- Step1. Insert the center hole of the end flange with the ball spline.
- Step2. Align the radial bolt hole with the center of the cutting plane of the ball spline, and install the bolt.
- Step3. Lock the side bolt so that the end flange securely clamps the ball spline.

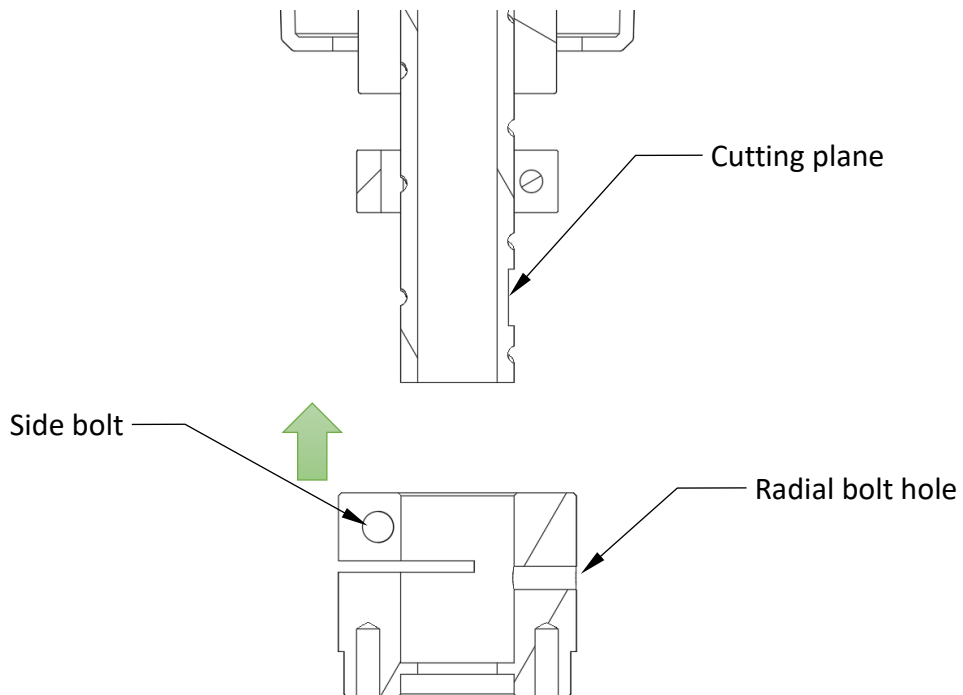

3.2. Interface

3.2.1. Pneumatic interface

The back panel of the arm has three air line connectors, and the three air lines are connected to the top panel of the B-arm through the arm body. Please refer to the following figure.

(The maximum working pressure of the air source is 8 kgf/cm².)

☉ RS405-LU Interface

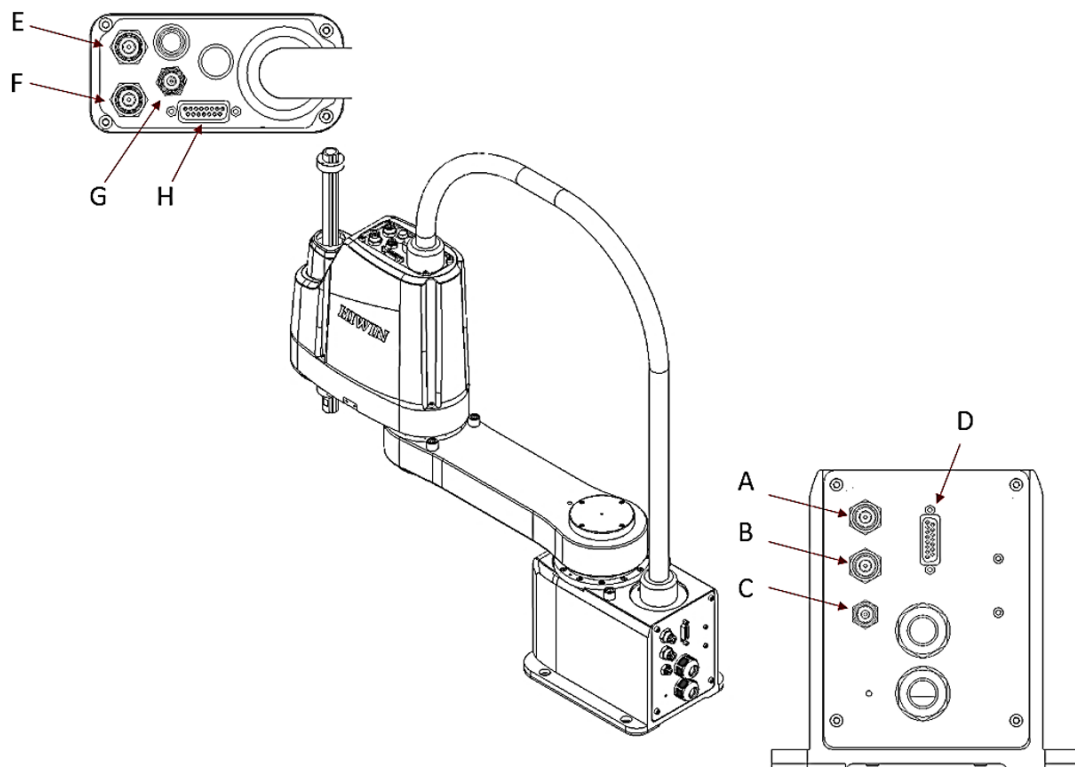

No.	Description(outer diameter × inner diameter)	Collar color
A、E	Suitable for (∅ 6mm×∅ 4mm) pneumatic pipe	Red
B、F	Suitable for (∅ 6mm×∅ 4mm) pneumatic pipe	N/A
C、G	Suitable for (∅ 4mm×∅ 2.5mm) pneumatic pipe	N/A

⊙ RS410-LU Interface

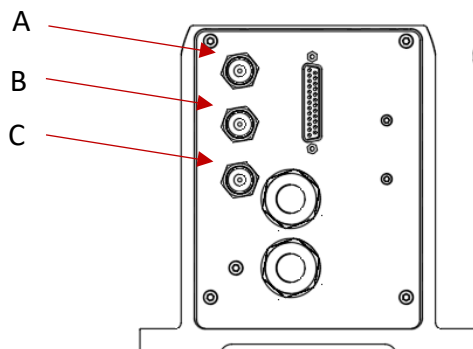
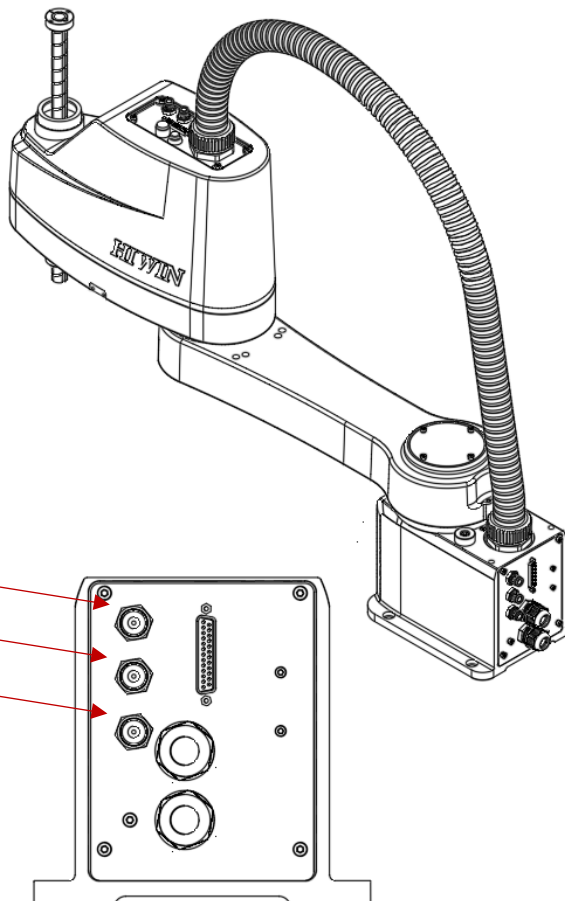
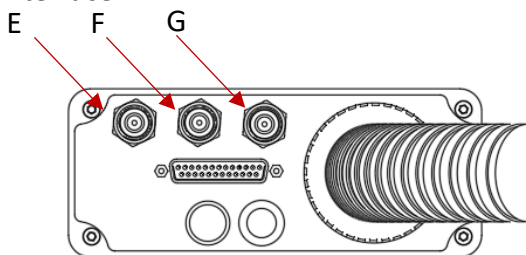

No.	Description(outer diameter × inner diameter)	Collar color
A、E	Suitable for (∅ 6mm×∅ 4mm) pneumatic pipe	Red
B、F	Suitable for (∅ 6mm×∅ 4mm) pneumatic pipe	Green
C、G	Suitable for (∅ 6mm×∅ 4mm) pneumatic pipe	N/A

3.2.2. Signal Interface

The back panel of the arm has a D-Sub connector, and cables pass through the arm body. The B-arm top panel D-Sub connector is shown below.

WARNING

❖ The maximum current per cable is 1A.

⦿ RS405-LU Interface

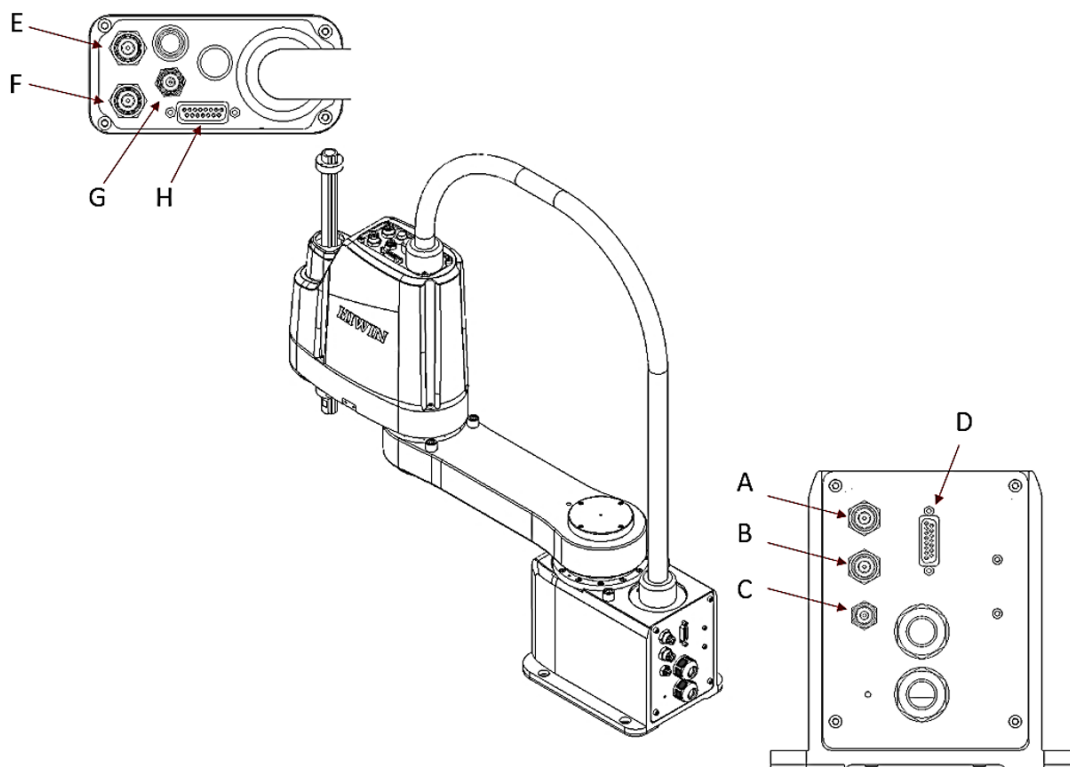

No.	Description
D、H	D-Sub 15Pin connector

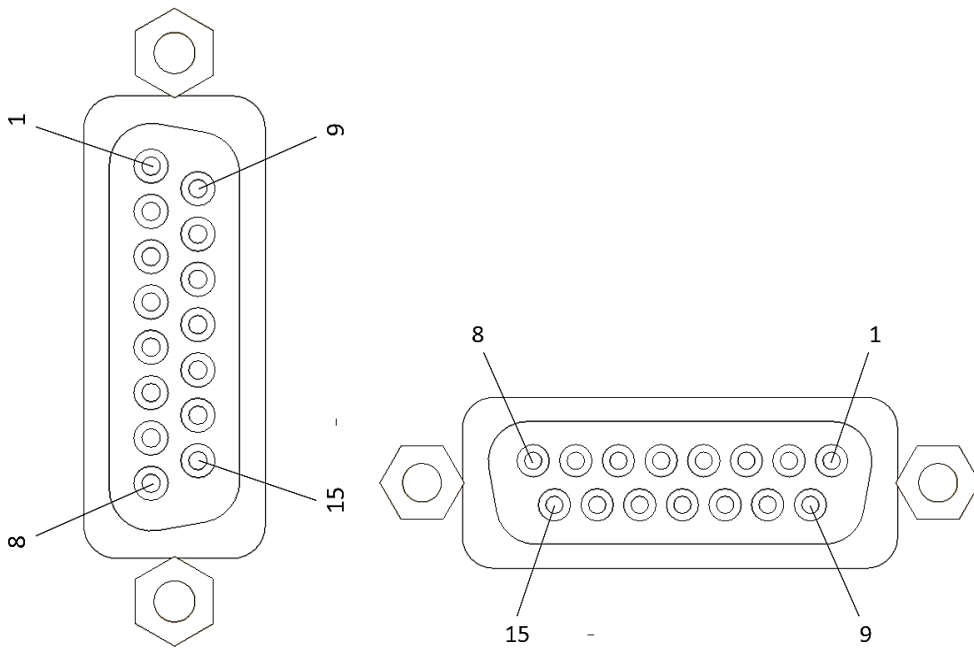

D	H
1	1
2	2
3	3
4	4
5	5
6	6
7	7
8	8
9	9
10	10
11	11
12	12
13	13
14	14
15	15

⊙ RS410-LU Interface

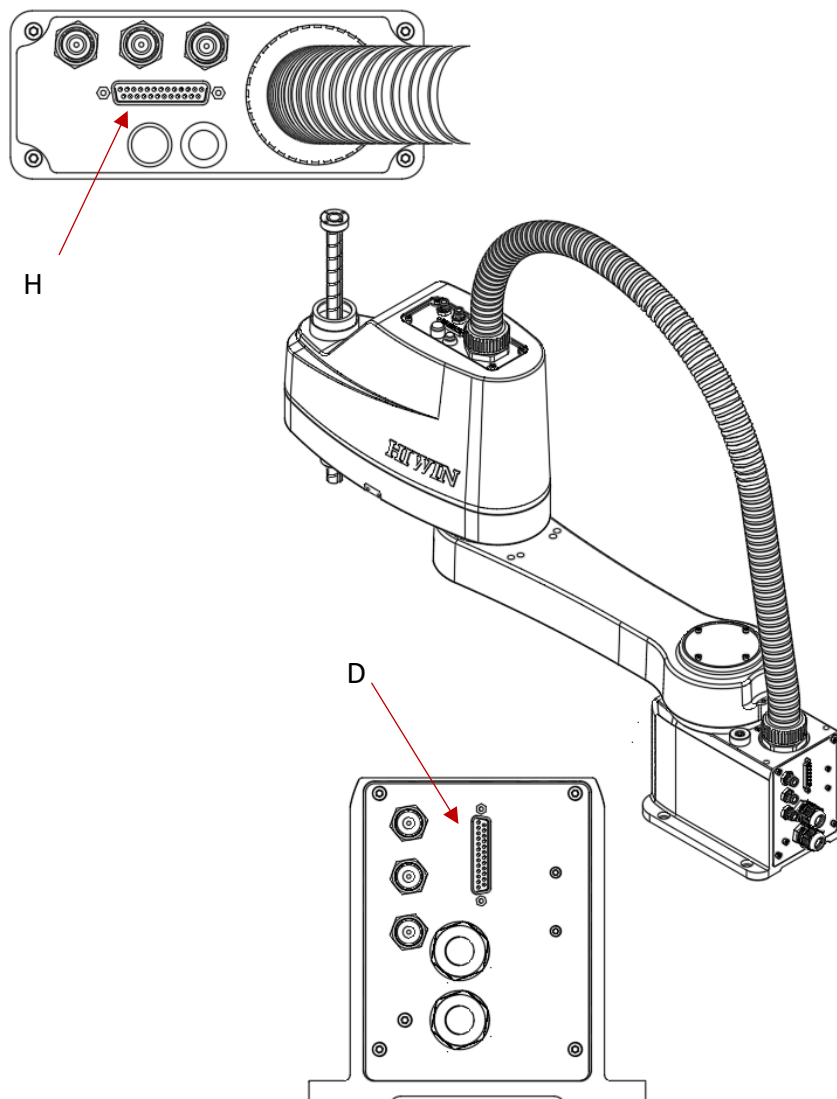

No.	Description
D、H	D-Sub 25Pin connector

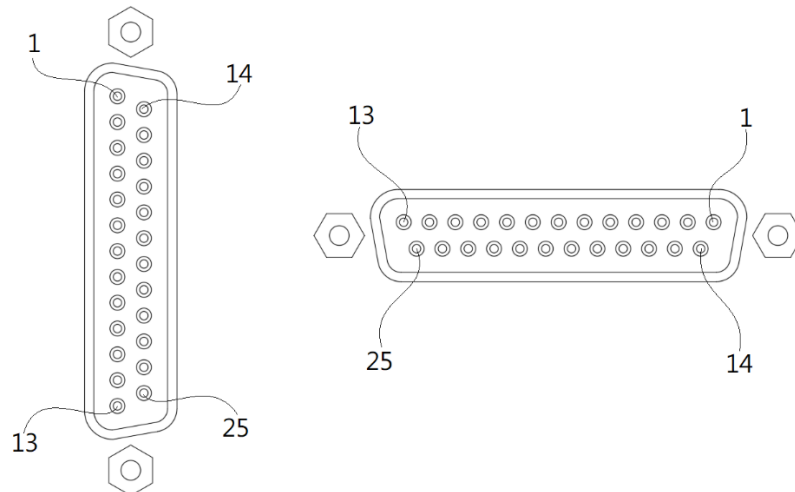

D	H
1	1
2	2
3	3
4	4
5	5
6	6
7	7
8	8
9	9
10	10
11	11
12	12
13	13
14	14
15	15
16	16
17	17
18	18
19	19
20	20
21	21
22	22
23	23
24	24
25	25

3.2.3. Equipment installation

There are multiple sets of threaded holes under the B-arm and on the side. You can use the bolt holes to install cameras, solenoid valves, etc., please refer to the following figure.

☉ RS405-LU Interface

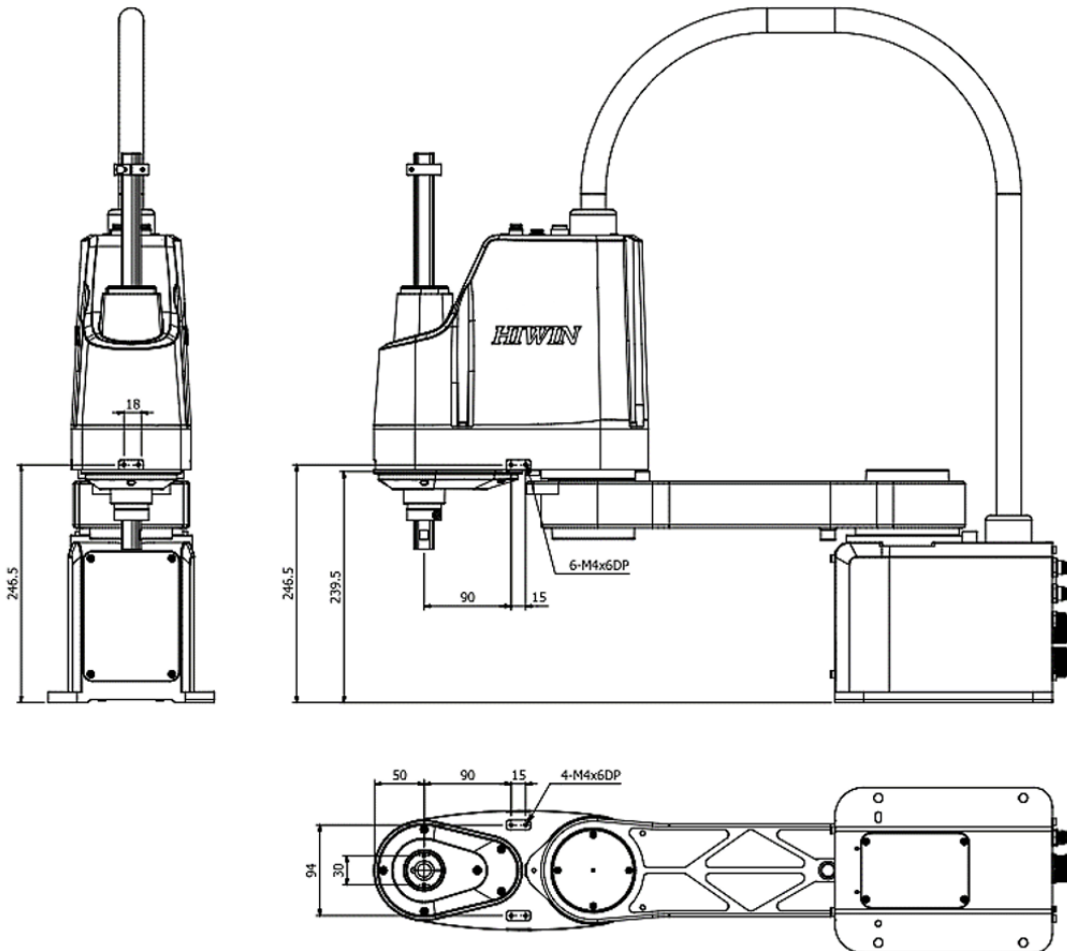

◎ RS410-LU Interface

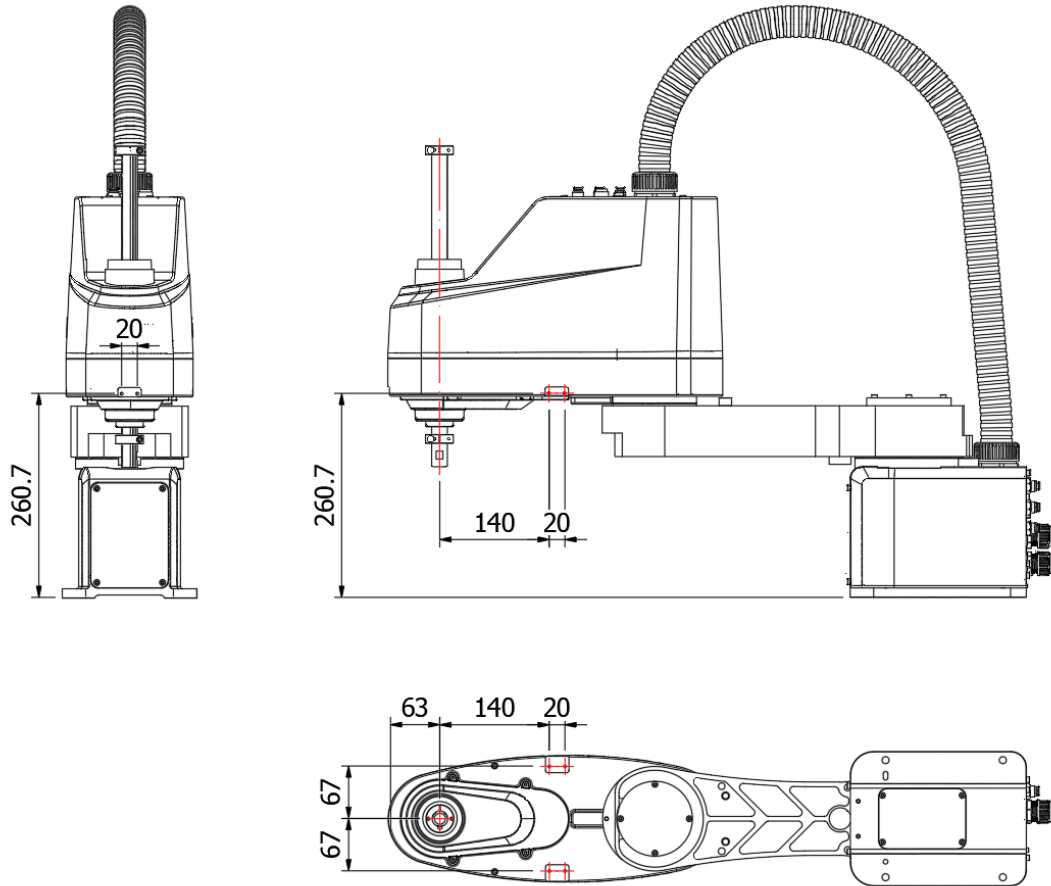

3.3. Inertia

3.3.1. Moment of inertia calculation

The moment of inertia is the amount indicating the resistance of the object to rotate. When installing the jig/end effector at the end of the ball spline, the moment of inertia of the load device must be considered.

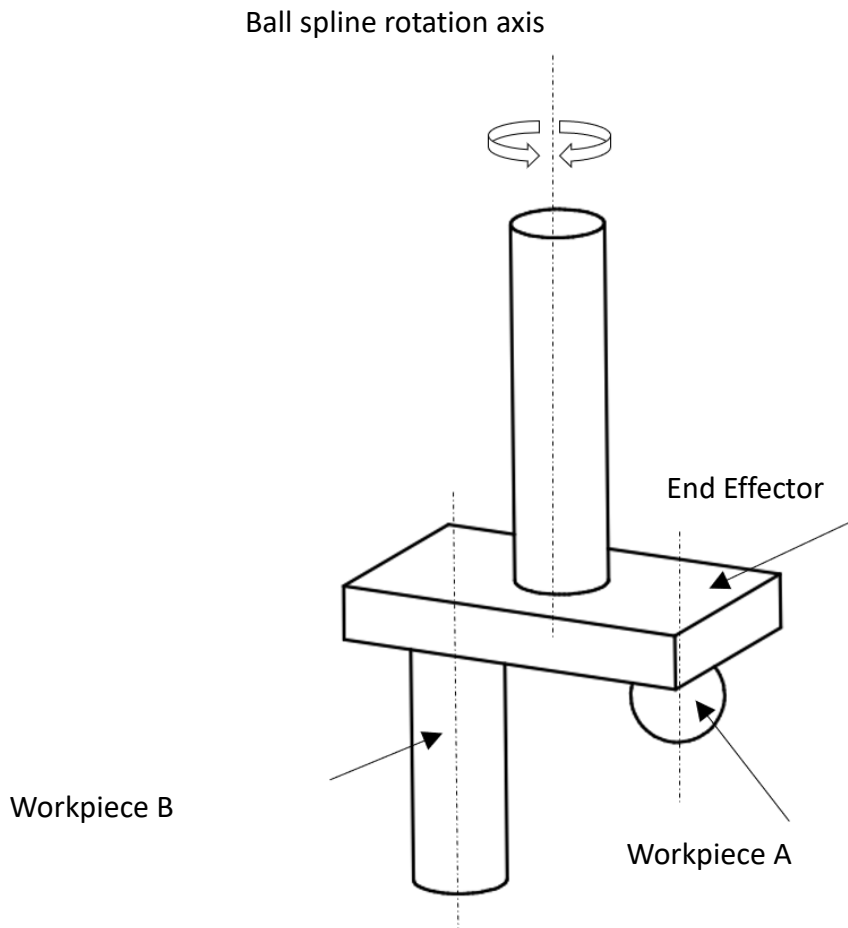

$$\boxed{\begin{array}{l} \text{Ball spline} \\ \text{Total moment} \\ \text{of inertia} \end{array}} = \boxed{\begin{array}{l} \text{End effector} \\ \text{moment of inertia} \end{array}} + \boxed{\begin{array}{l} \text{Workpiece A} \\ \text{Moment of} \\ \text{inertia} \end{array}} + \boxed{\begin{array}{l} \text{Workpiece B} \\ \text{Moment of inertia} \end{array}}$$

CAUTION

- ❖ Ensure to calculate the total moment of inertia at the end of the ball spline before use. This value is within the arm's rated/maximum allowable inertia.
- ❖ If the specification value is exceeded, the performance and life of the arm will be degraded.

The calculation method of the moment of inertia of each object is shown in (a), (b), and (c) below. Please refer to the following calculation method of the moment of inertia of the basic shape to determine the moment of inertia of the object.

(a) Moment of inertia of a rectangular object

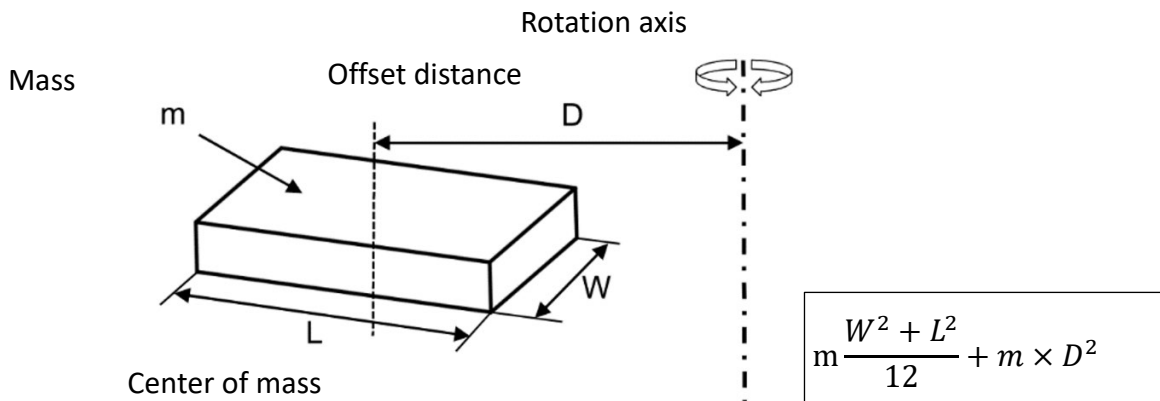

(b) Moment of inertia of a Cylinder

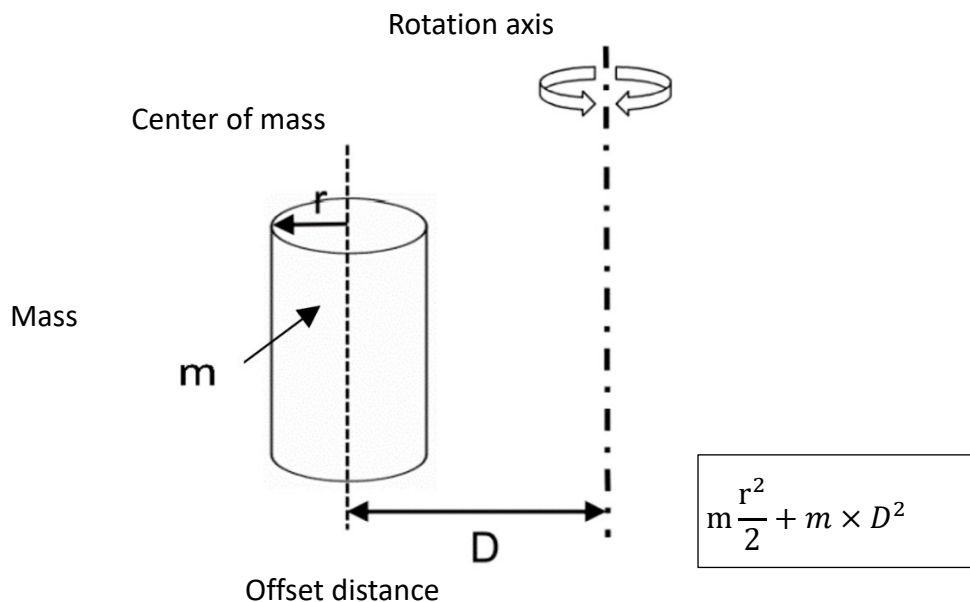

(c) Moment of inertia of a sphere

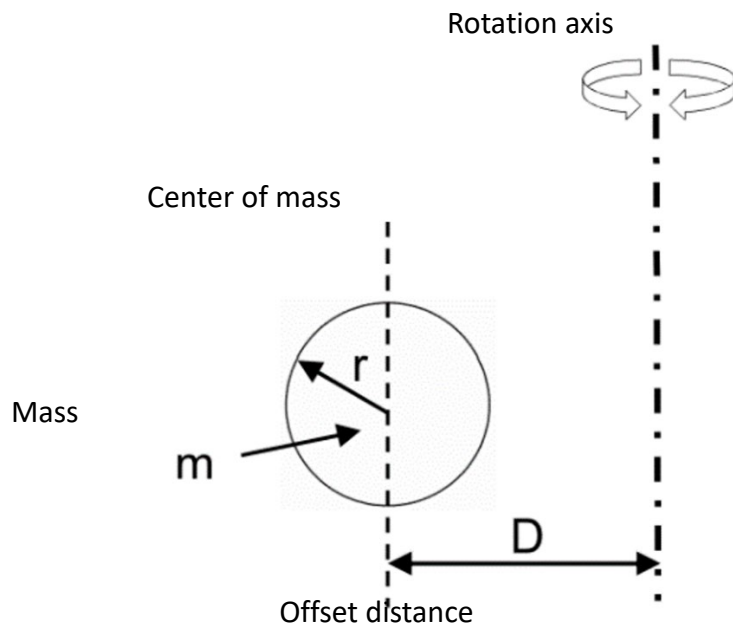

$$m \frac{2}{5} r^2 + m \times D^2$$

3.3.2. End effector extension load

The end extension load calculation is shown in the figure and will vary depending on the shape of the load object. It is recommended to calculate the inertia actually.

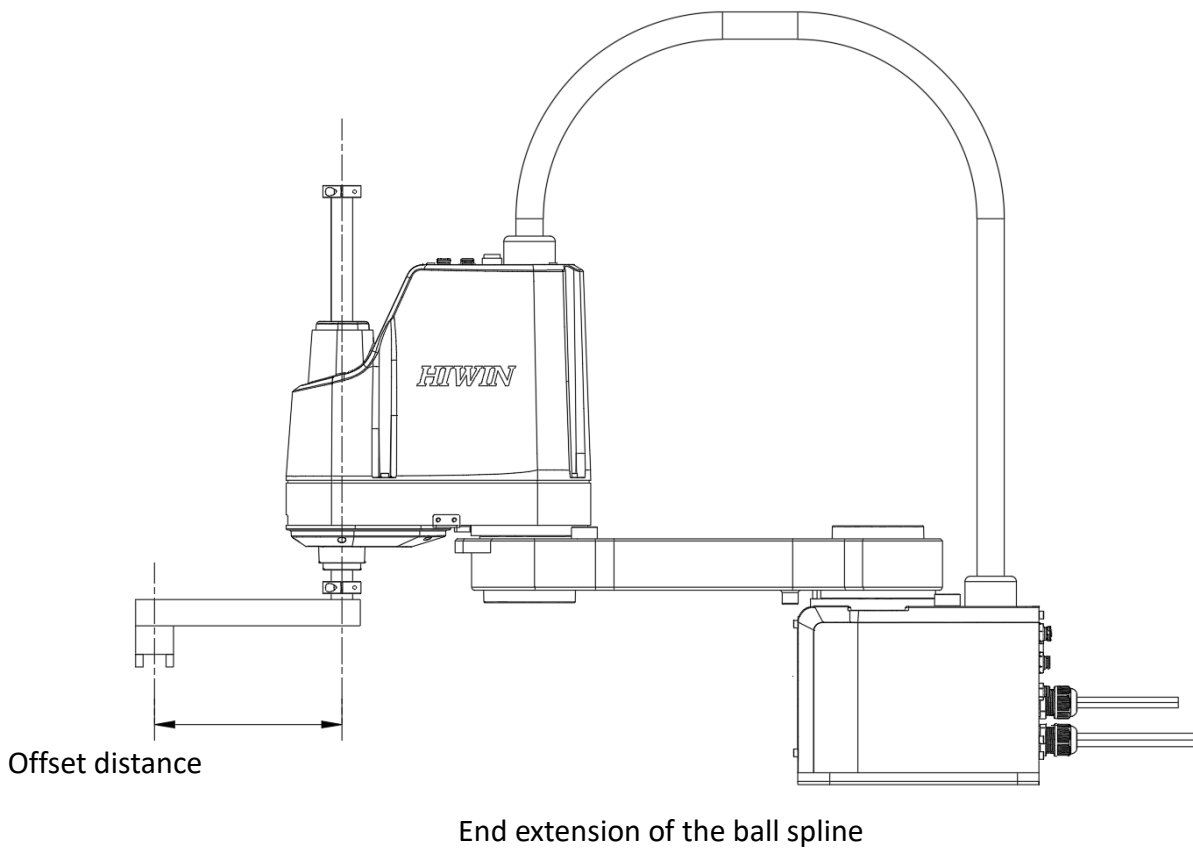

4. Adjustment

4.1. Zero position setting

The kit includes a calibration tool as shown below. When calibrating, press the emergency stop button on the robot arm to push the robot arm freely until the calibration tool can be aligned with the calibration hole or the set position.

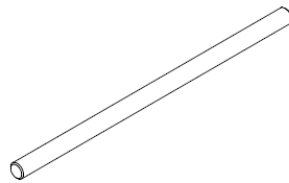

Calibration tool

⊙ J1-axis calibration sequence is as follows

- Step1. Press the emergency stop button and push the A-arm with your hand until the A-arm matches the calibration hole of the base.
- Step2. Insert the calibration hole from top to bottom using the calibration tool.
- Step3. Select the first axis through the software and set the position.
- Step4. Remove the calibration tool after the position is determined.

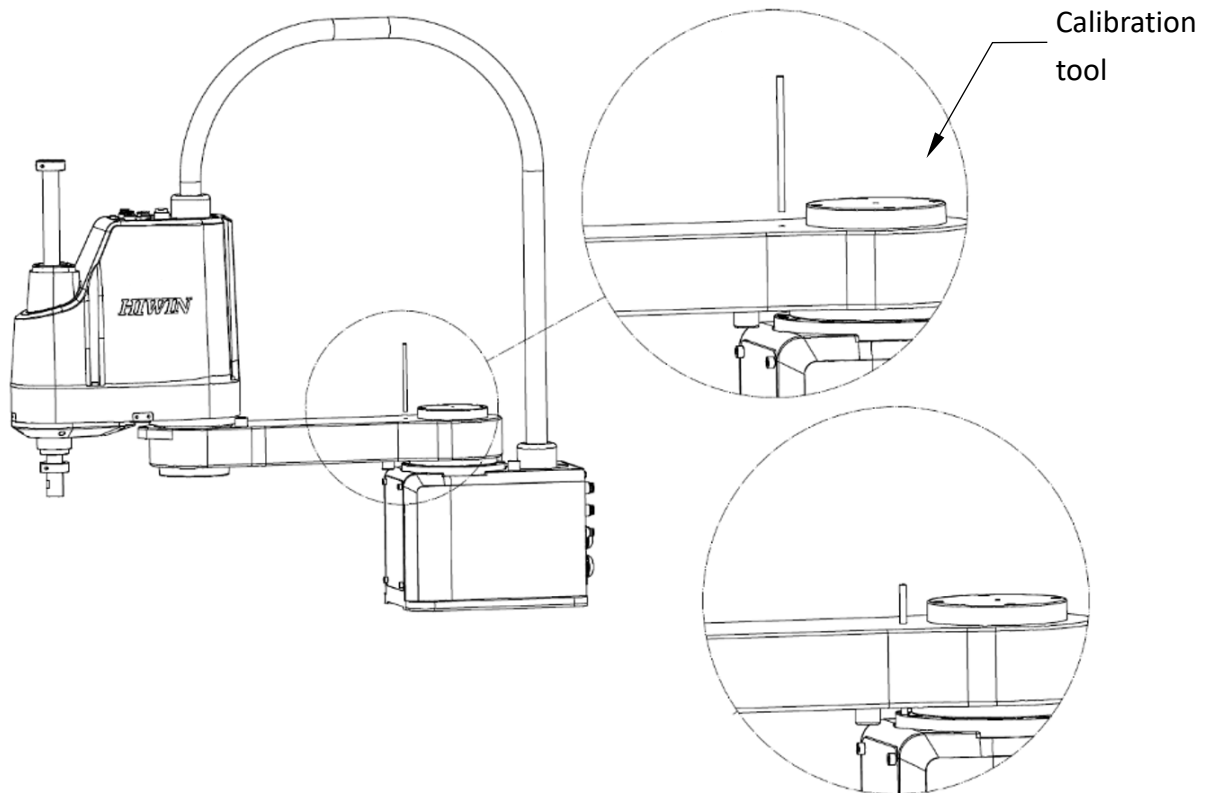

J1-axis calibration diagram

⊙ J2-axis calibration sequence is as follows

- Step1. Press the emergency stop button and push the B-arm with your hand until the B-arm matches the correction hole of the A-arm.
- Step2. Insert the calibration hole from bottom to top using the calibration tool.
- Step3. Select the second axis through the software and set the position.
- Step4. Remove the calibration tool after the position is determined.

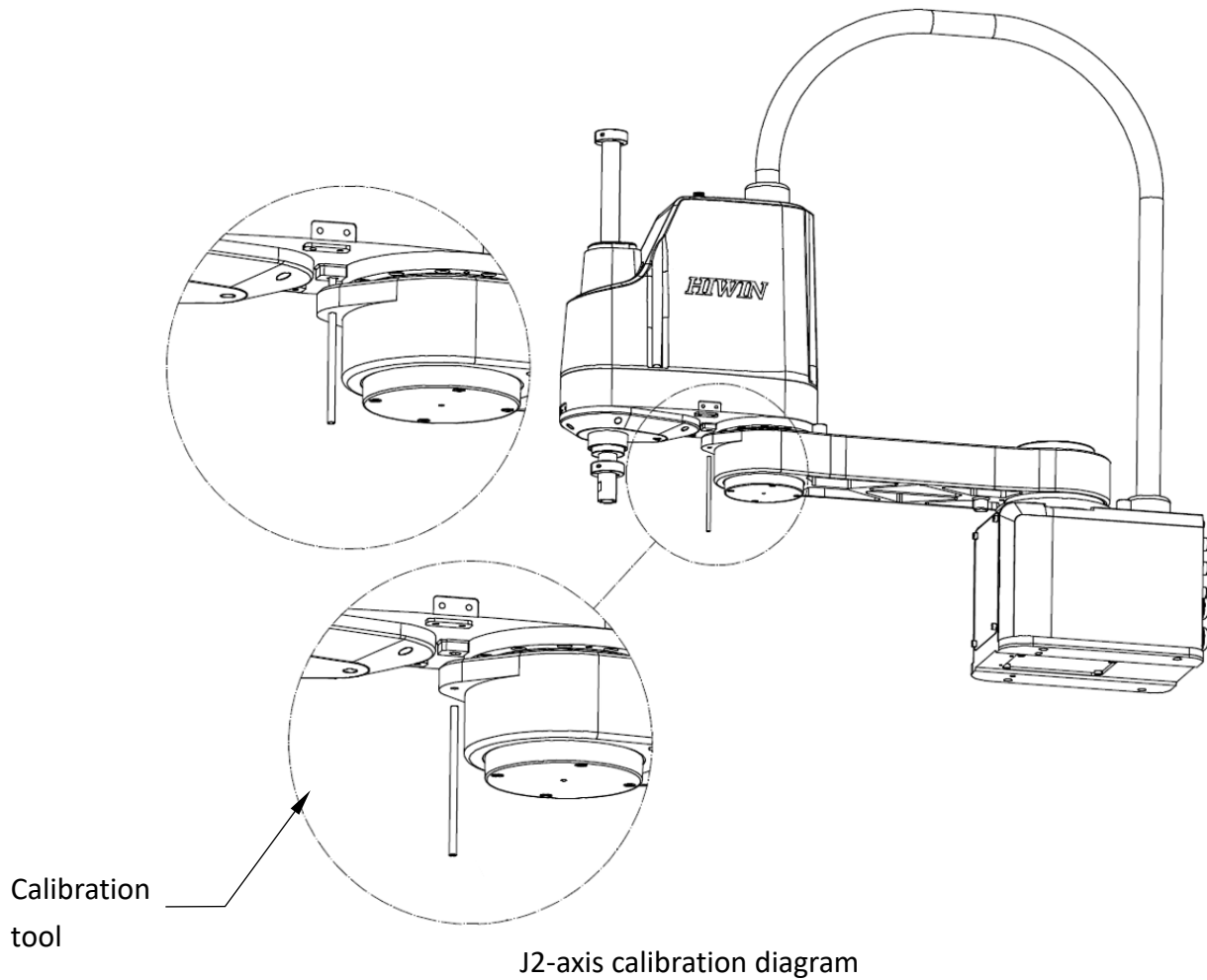

⊙ J3,J4-axis calibration sequence is as follows

- Step1. Confirm that the distance between the stop ring and the ball spline is 30mm, as shown below.
- Step2. After pressing the emergency stop button, hold the brake release switch and push the ball spline with your hand until the stop ring comes into contact with the robot body. Turn the ball spline by hand until the cutting plane of the ball spline faces the front of the robot, and release the brake release switch.
- Step3. Confirm that the stop ring is in contact with the body of the robot. The upper surface of the ball spline faces the front of the robot.
- Step4. Select the J3-axis through the software and set the position.
- Step5. Select the J4-axis through the software and set the origin position.
- Step6. Press the brake release switch again and push the ball spline down about 50mm.

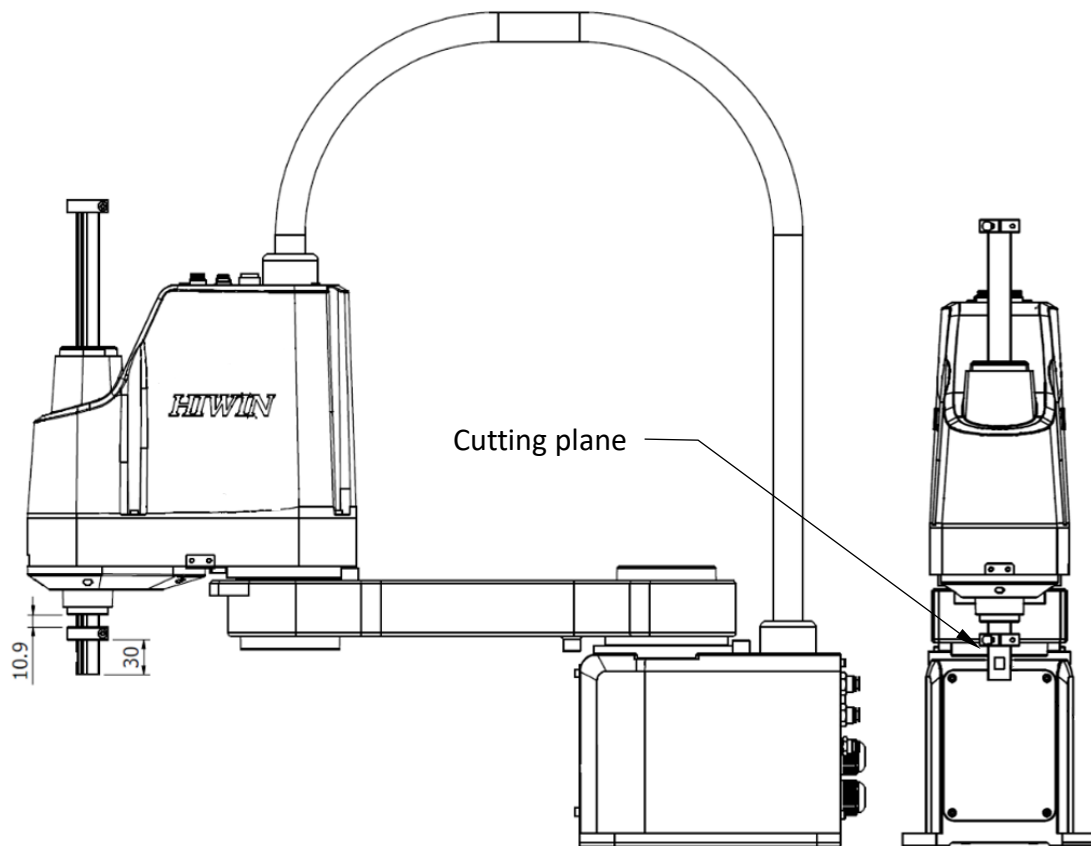

J3,J4-axis calibration diagram

5. Maintenance

This chapter will introduce the daily inspection and periodic inspection items and treatment methods of the robot arm, as well as the basic maintenance items including disassembly, installation of the outer casing for internal maintenance, inspection and replacement of each shaft belt, oil supply and matters needing attention. Steps to replace the battery.

CAUTION

- ❖ The maintenance time defines the annual operation time as 3840 hours. If the annual operation time exceeds the current time, it should be converted to the maintenance time of 3840 hours/year.

The cover is locked above the B-arm and contains J2, J3, J4 motor and 3 transmission belts. By opening the cover, check whether there is any foreign matter inside the B-arm, whether the ball spline is abnormal and whether the belt is worn.

DANGER

- Before maintenance, please turn off the power of the controller and remove the power supply wiring. Do not perform any maintenance and maintenance actions when the robot arm is moving to avoid the operator's electric shock or the malfunction of the robot arm.

Remove the cover:

- Step1. Turn off the power of the controller.
- Step2. Remove the outer 8 bolts. And keep the bolts in a safe place to avoid losing.
- Step3. Remove the outer cover of the robot arm from bottom to top. And move the cover to the top of the base.

⦿ RS405-LU

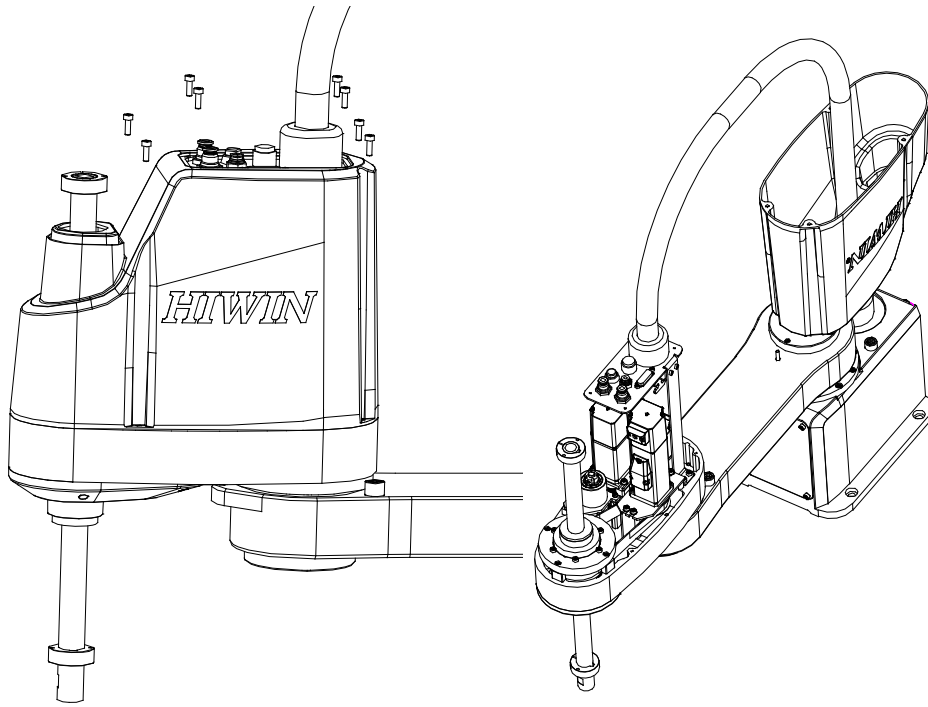

⦿ RS410-LU

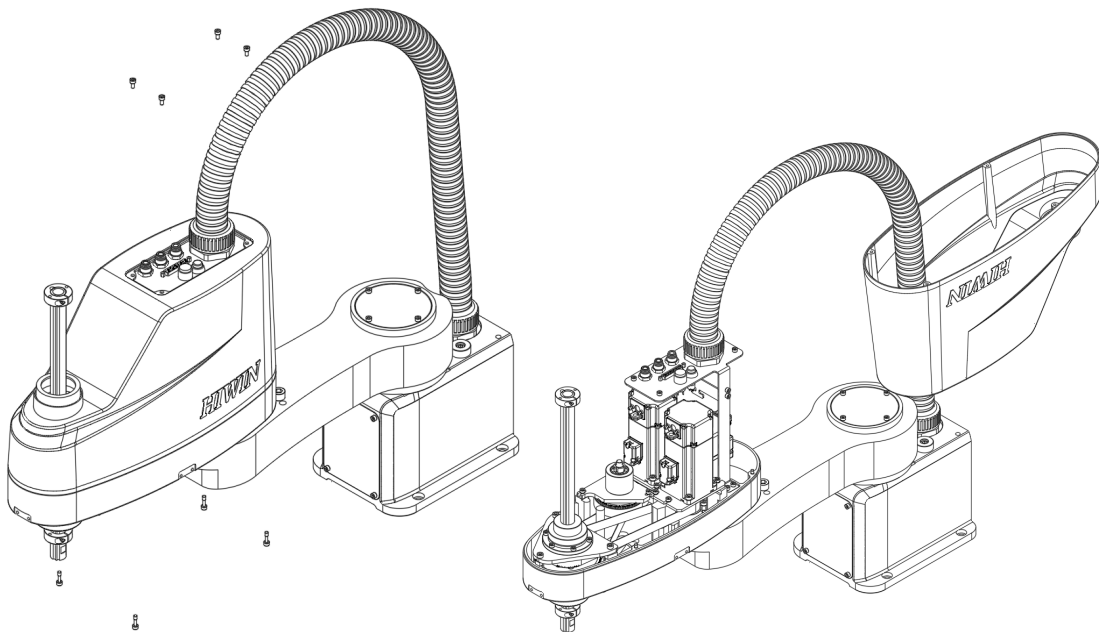

Installing cover:

- Step1. Turn off the power of the controller.
- Step2. Install the arm cover from the top to bottom.
- Step3. Confirm that the cover does not interfere with any parts and cables.
- Step4. Lock with the external 8 bolts.

 **CAUTION**

- ❖ When installing the cover, pay attention to whether the internal wires are excessively bent to avoid poor contact or damage to the internal cables.
- ❖ When installing the cover, pay attention to whether the ball spline will interfere with the cover. After confirming, the fixing bolt can be locked and the cover can be installed.

5.1. Daily Inspection

Daily inspections should be performed before each system operation, as shown below.

Daily checklist

Inspection item	Remedies
Before turning power ON	
Are any of the robot installation bolts, cover installation bolts and end effector installation bolts loose?	Securely tighten the bolts.
Are all the cables securely connected? Such as the power and signal cable, grounding cable, the cable for teach pendant and the cable connected the robot and other equipment.	Securely connect. If loosen, please ensure the cables are securely connected.
Is the pneumatic system normal? Are there any air leak, drain clogging or hose damage? Is the air source normal?	Drain the drainage system and replace the leaking component. If needed, please contact HIWIN directly.
After turning power ON	
Is there any unusual motion or unusual noise when power is ON?	<p>The robot installation bolts might not be securely tightened to the installation surface. Securely tighten the bolts to appropriate torque.</p> <p>If the roughness of the installation surface is uneven, modify the installation surface to the reasonable surface roughness.</p> <p>The base might not be sufficiently rigid. Please replace the base to make it more rigid.</p> <p>There might be foreign material between the robot and the installation surface. Please remove it.</p> <p>Some operating positions might exceed the mechanism limit. Please reduce the load, speed or acceleration.</p> <p>The timing belt might loosen or not be in correct position. Please replace or adjust the timing belt.</p> <p>If the grease of the reducer has not</p>

	<p>been changed for a period of time. Please change the grease. If the above situations has been excluded, it is likely that the rolling surface of bearing or the gear tooth surface of reducer has been damaged. Please contact HIWIN directly.</p>
<p>The repeatability is not within the tolerance.</p>	<p>The Zero-position of the robot might be rewritten. Please set the Zero-position. The Zero-position data will be lost if the backup batteries is dead. Please replace the backup batteries and set the Zero-position. The Robot J1 base retaining bolt might loosen. Please tighten it to the appropriate torque.</p>

- ⊙ The items and time for regular inspection are shown below.

Daily checklist

Inspection item	Remedies
Inspection item A (1 month / 320 hours)	
Is the robot dirty or dusty?	Clean and check each part of the robot.
Inspection item B (3 months / 960 hours)	
Check the ventilation system of the controller.	If it is dusty, turn off the power and clean the ventilation system of the controller
Ball spline grease lubrication	Ball spline lubrication
Inspection item C (6 months / 1920 hours)	
Check whether the friction at the timing belt teeth is severe. Check whether the tension of timing belts at each axis is abnormal or deviated.	If the teeth are missing or the friction at the timing belt is severe, replace it. Adjust the tension to the standard value, and avoid over tightness or looseness. Please refer to the user manual.
Inspection item D (1year / 3840 hours)	
Replace the battery in the manipulator.	Replace the battery. Please refer to the user manual.
Inspection item E (3years/11520hours)	
Change the grease of the reducer. Change the timing belts	Change the grease. Change the timing belts. Please refer to the user manual.

 **CAUTION**

- ❖ It is normal that the belt produces debris during operation, but if it happens right after cleaning the belt, it is recommended to replace the belt.

Inspection schedule

1 month	Check item A				
2 months	Check item A				
3 months	Check item A	Check item B			
4 months	Check item A				
5 months	Check item A				
6 months	Check item A	Check item B	Check item C		
7 months	Check item A				
8 months	Check item A				
9 months	Check item A	Check item B			
10 months	Check item A				
11 months	Check item A				
12 months	Check item A	Check item B	Check item C	Check item D	
	Monthly	Quarterly	Biannual	Annual	
36 months	Check item A	Check item B	Check item C	Check item D	Check item E

5.2. Maintenance Item

5.2.1. Battery Replacement

The absolute encoder is used for position recording. When the power is interrupted, the backup battery must be used to memorize the current position of the encoder. The robot has been installed with the battery at the time of shipment. Usually, the battery replacement time is about one year, but this varies depending on the condition of the arm used. Users need to check regularly and replace before the battery runs out. The following figure shows how to replace the battery of the robot arm:

- Step1. Confirm the wiring between the robot arm and the controller and turn on the controller.
- Step2. Press the emergency stop problem.
- Step3. Open the battery cover. (Hexagon socket head screw, M3×0.5P×6L)
- Step4. Replace four spare batteries one by one, the battery is 3.6V. If all the batteries are removed at one time, the encoder data will be lost and the robot must be recalibrated.
- Step5. Put the battery cover back to robot.

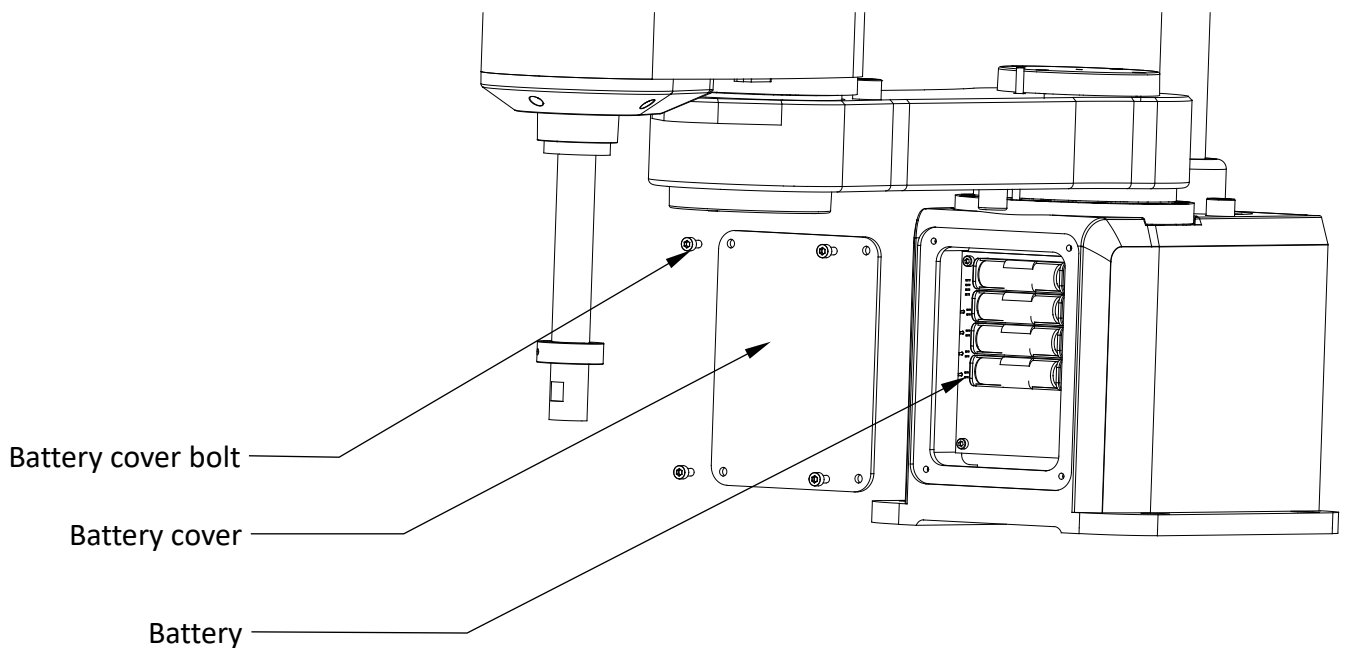

CAUTION

Please make sure that all 4 batteries are new and avoid mixing old and new.

5.2.2. Timing Belt Replacement

The belts on axis 3 and axis 4 of robot arm have been adjusted before the shipment. The robot arm movement will cause the belt wear out and the belt tension will lower than standard value. Therefore, the belt tension needs to be regularly inspected, maintained and replaced.

⦿ Belt Replacement Timing

Check the belt condition every six months. If there is a crack in the belt tooth, the belt tooth wears to about half of the tooth width or the belt breaks, the belt must be replaced.

⚠ CAUTION

❖ When replacing the belt, please refer to chapter 4.1 for robot calibration.

⦿ Belt Tension

Please use the belt tension meter to check the belt tension. The specifications are as follows.

⚠ CAUTION

❖ After long-term operation, it's normal to have some wear out. It is recommended to replace the belt if there is a lot of wear out.

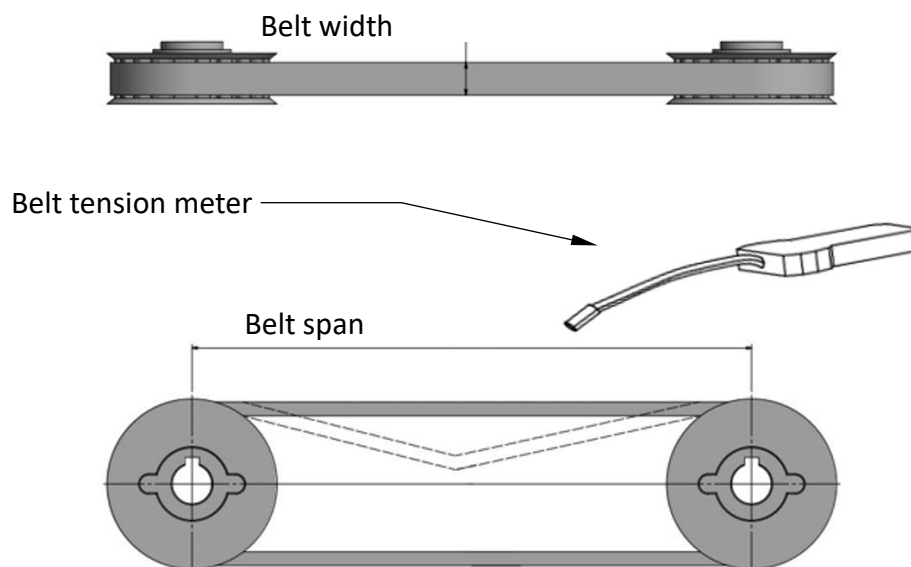

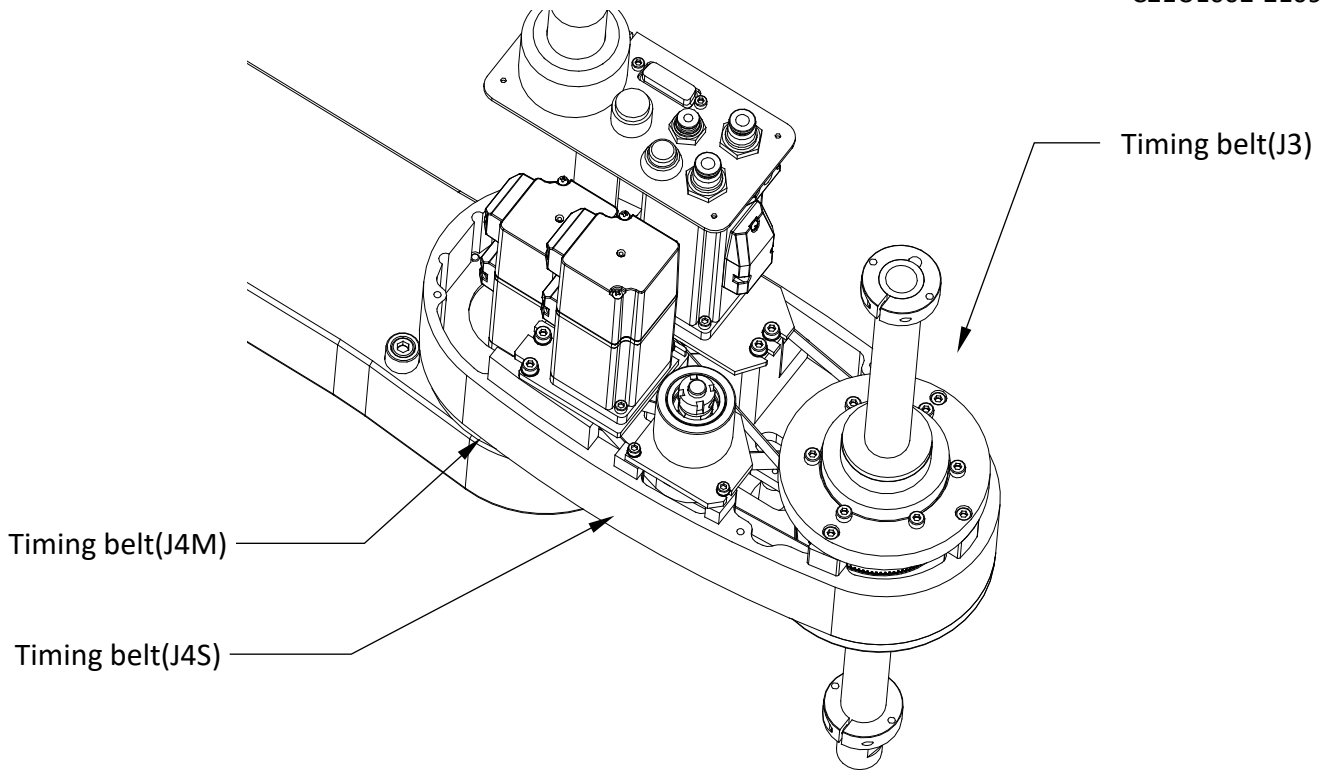

⊙ RS405-LU Recommended tension table

Belt	Spec.	Belt width (mm)	Belt span (mm)	tension (N)
Timing belt(J3)	100-S3M-396	10	124	50 ±5
Timing belt (J4M)	100-S2M-172	10	44.3	28 ±5
Timing belt (J4S)	150-S2M-300	15	86.3	45 ±5

⊙ RS410-LU Recommended tension table

Belt	Spec.	Belt width (mm)	Belt span (mm)	tension (N)
Timing belt(J3)	150-S3M-564	15	210	73 ±5
Timing belt (J4M)	150-S3M-285	15	63	73 ±5
Timing belt (J4S)	200-S3M-480	20	145	98 ±5

5.2.3. Ball Spline Lubrication

When the spline is exposed to the open environment for a long time, it is easy to be contaminated with environmental dust or insufficient lubrication. It is recommended that the user clean and maintain every 3 months or 100km, and evenly apply grease (G04, 5C.C.) to the surface of the ball spline and the groove to maintain the smooth running

 **DANGER**

- Please turn off the power of the controller and remove the power cable to avoid electric shock before maintenance work.

 **CAUTION**

- ❖ Unauthorized person should not disassemble the spline screw by themselves.

5.2.4. Reducer Lubrication

During the operation of the reducer, the mechanical structure needs to be fully lubricated to prevent wear out. Once the mechanical structure wears out, it may cause abnormal noise of the reducer, and even cause poor positioning accuracy.

 **CAUTION**

- ❖ Unauthorized person should not disassemble the reducer by themselves.
- ❖ Unauthorized person should not replace the oil by themselves.

Reducer Maintenance Item List

Item	Duration	Description
Reducer grease replacement	Running 11520 hours or 3 years	Please refer to table
Reducer backlash inspection	2.5 years	If it is bigger than the allowable value, it is recommended to replace the new product

Reducer Lubrication

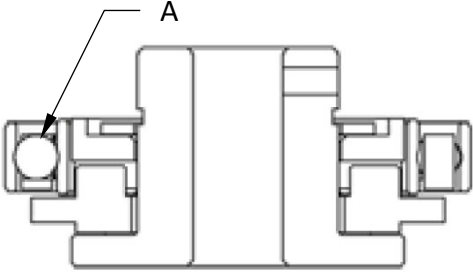
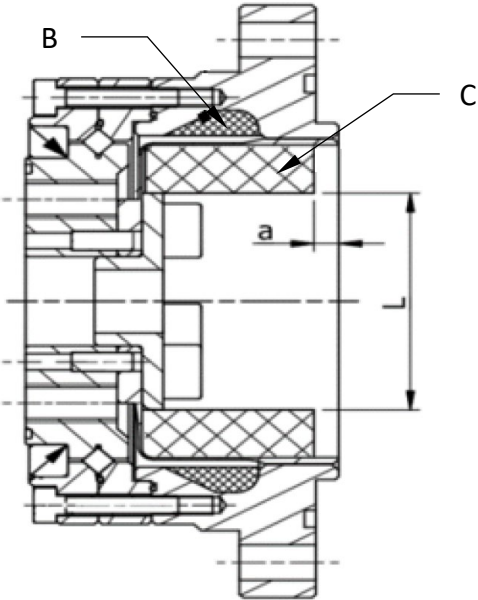
Grease application area	Method	Figure
Groove	Fill the space A with grease.	
Reducer	<ol style="list-style-type: none"> Remove the grease in area B. After that, fill the space with new grease. Fill the grease in space C. Please check the following table for the grease filling amount. 	

Grease filling amount

Component	Spec.	Unit	RS405-LU		RS410-LU	
			J1	J2	J1	J2
Flexspline inner wall		g	40~52	21~27	73~82	40~52
Circular spline inner wall		g	14	6	20~27	14
a(reference dimension)		mm	5	3	5	5
L(reference dimension)		mm	47~51	38~41	58	47~51

⊙ RS405-LU reducer disassembly

➤ J1 reducer disassembly

- Step1. Turn off the power of the controller.
- Step2. Remove the M3 bolts from the bolt cover.
- Step3. Remove the bolt cover on the A-arm.
- Step4. Remove the A-arm M8 bolts.
- Step5. Remove the A-arm vertically upwards.

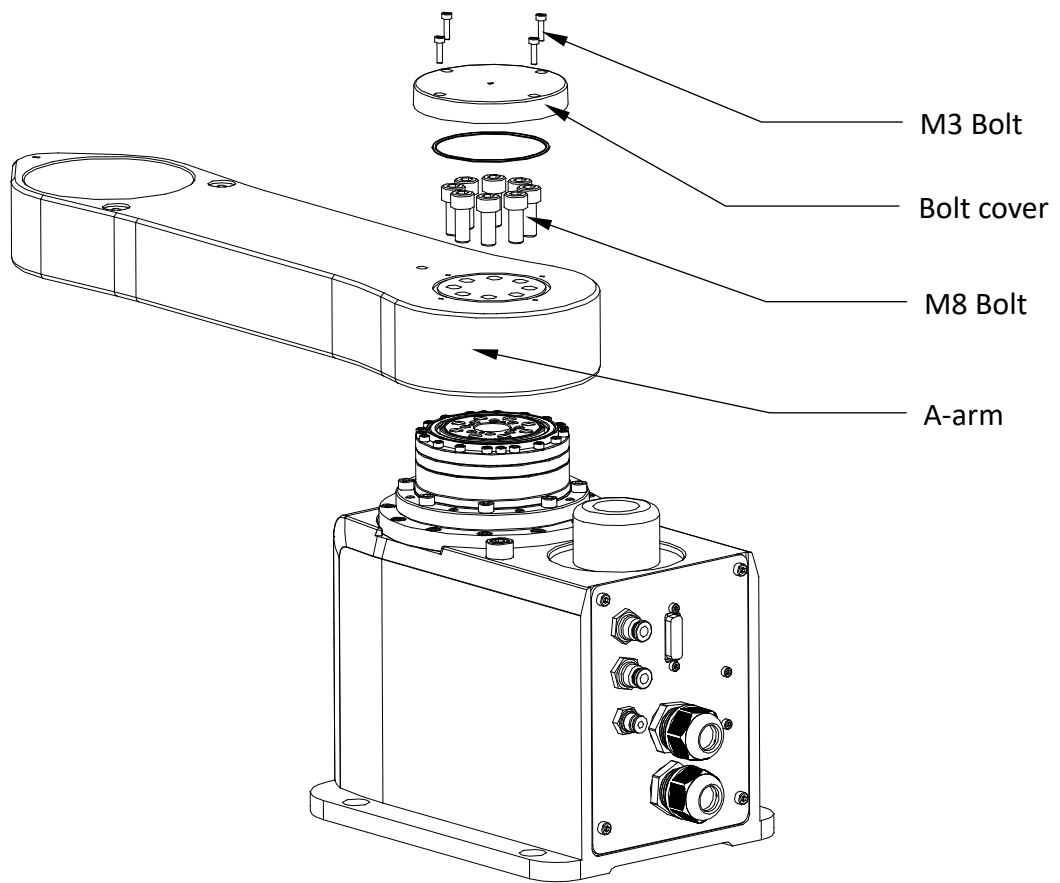

- Step6. Remove the reducer flange M5 bolts.
- Step7. Remove the reducer body vertically upwards.
- Step8. Remove the M4 bolt from the motor and wave generator.
- Step9. Remove the wave generator vertically.

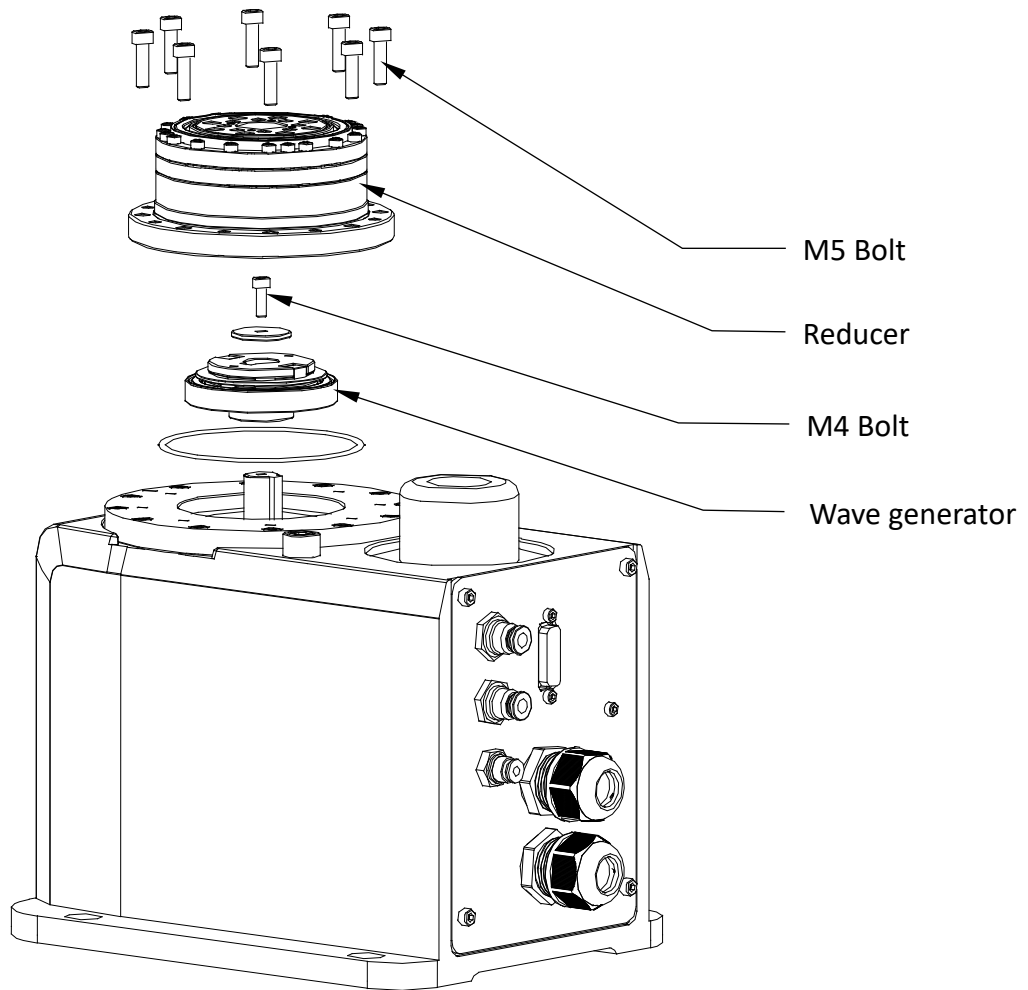

➤ J2 reducer disassembly

- Step1. Turn off the power of the controller.
- Step2. Remove the M3 bolts from the bolt cover.
- Step3. Remove the bolt cover on the A-arm.
- Step4. Remove the A-arm M8 bolts.
- Step5. Remove the B-arm.

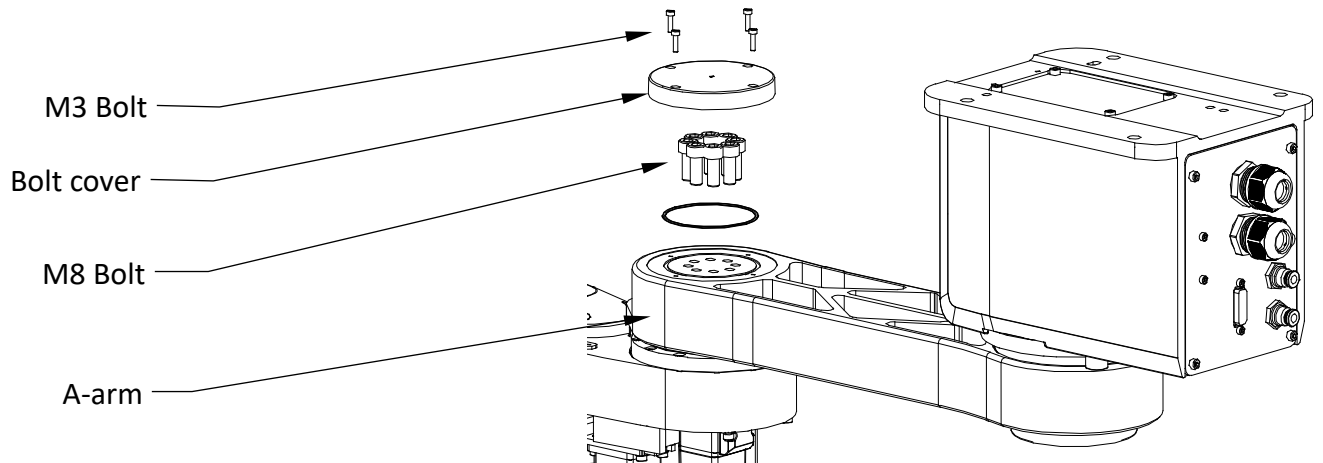

- Step6. Remove the reducer flange M5 bolts.
- Step7. Remove the reducer body vertically upwards.
- Step8. Remove the M3 bolt from the motor and wave generator.
- Step9. Remove the wave generator vertically upwards.

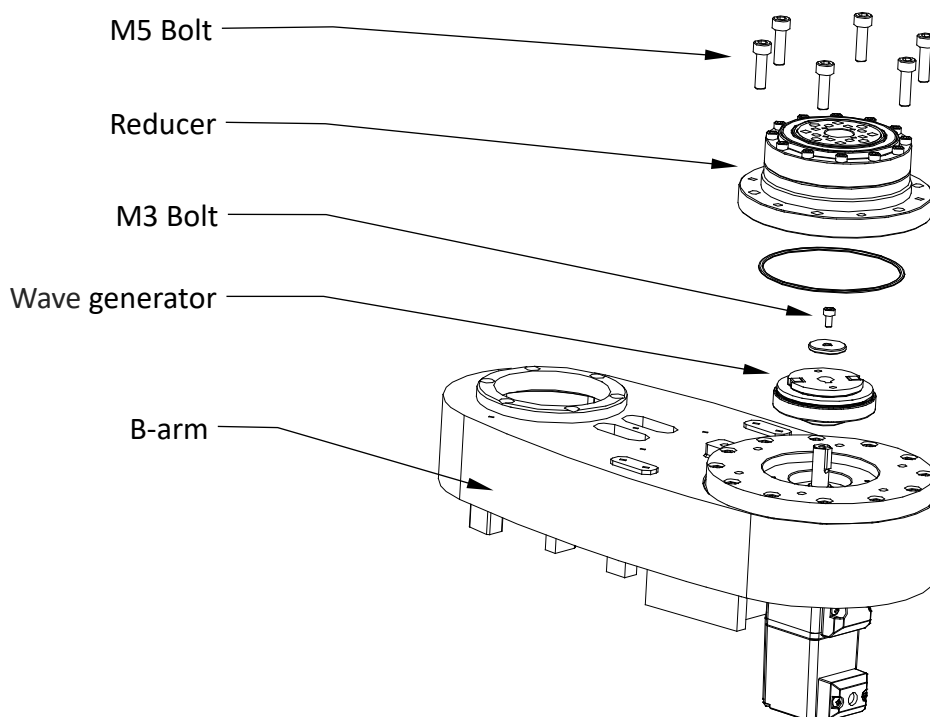

⊙ RS410-LU reducer disassembly

➤ J1 reducer disassembly

- Step1. Turn off the power of the controller.
- Step2. Remove the M4 bolts from the bolt cover.
- Step3. Remove the bolt cover on the A-arm.
- Step4. Remove the A-arm M10 bolts.
- Step5. Remove the A-arm vertically upwards.

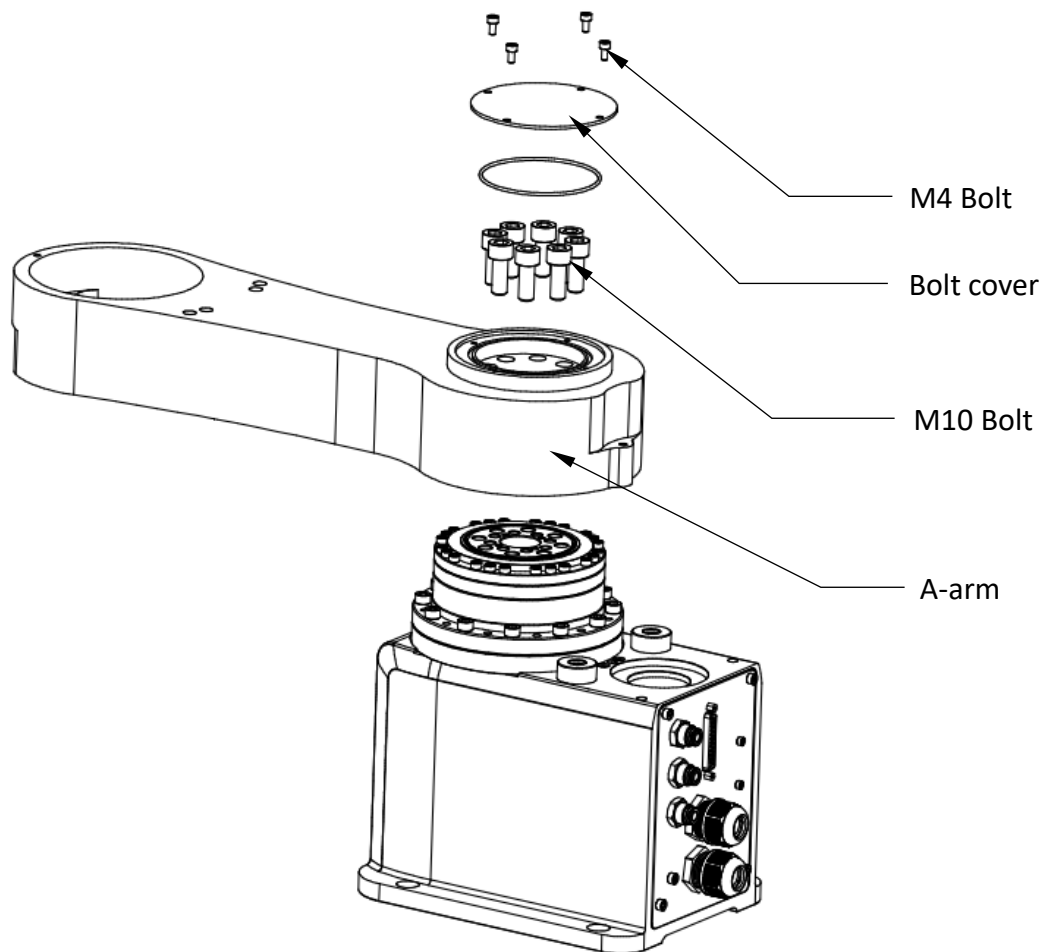

Step6. Remove the reducer flange M5 bolts.

Step7. Remove the J1 motor module vertically upwards.

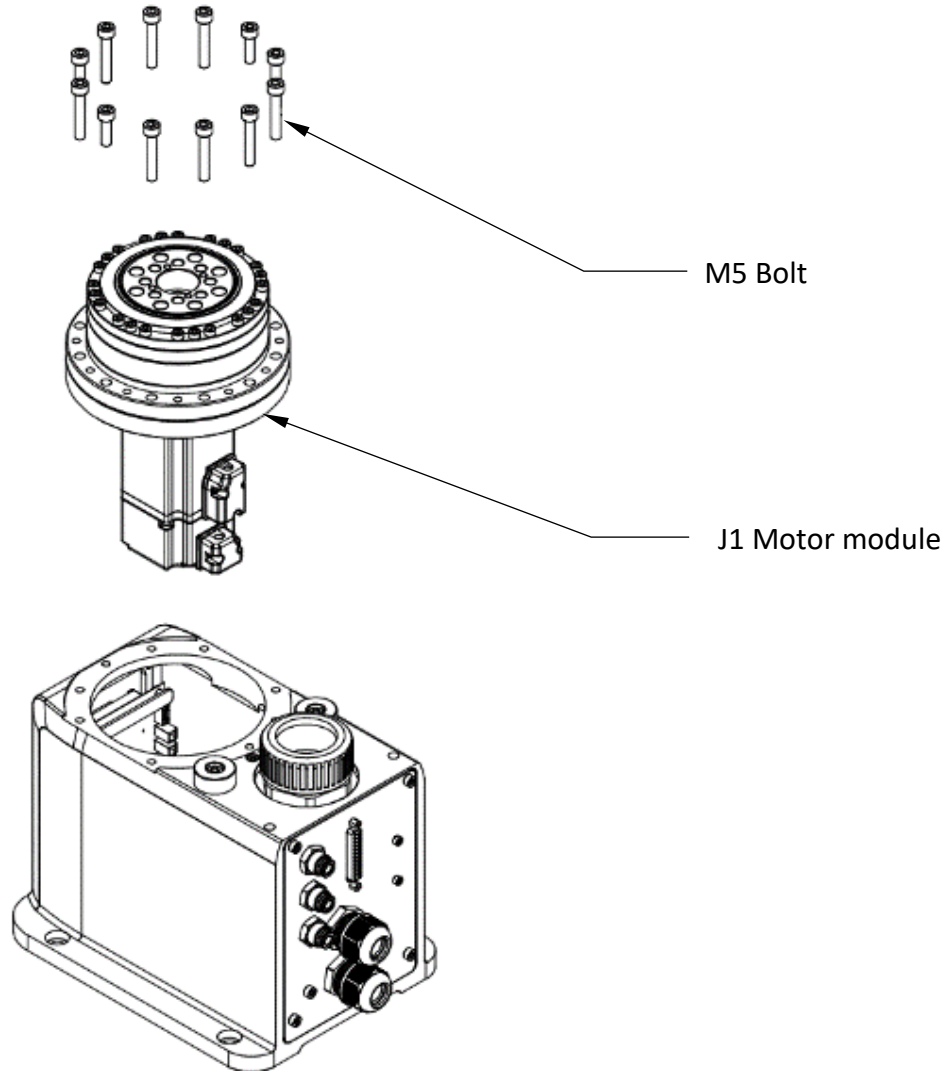

Step8. Remove the M4 bolt from the motor and wave generator

Step9. Remove the M6 bolts.

Step10. Separate the reducer, wave generator and motor in the axial direction.

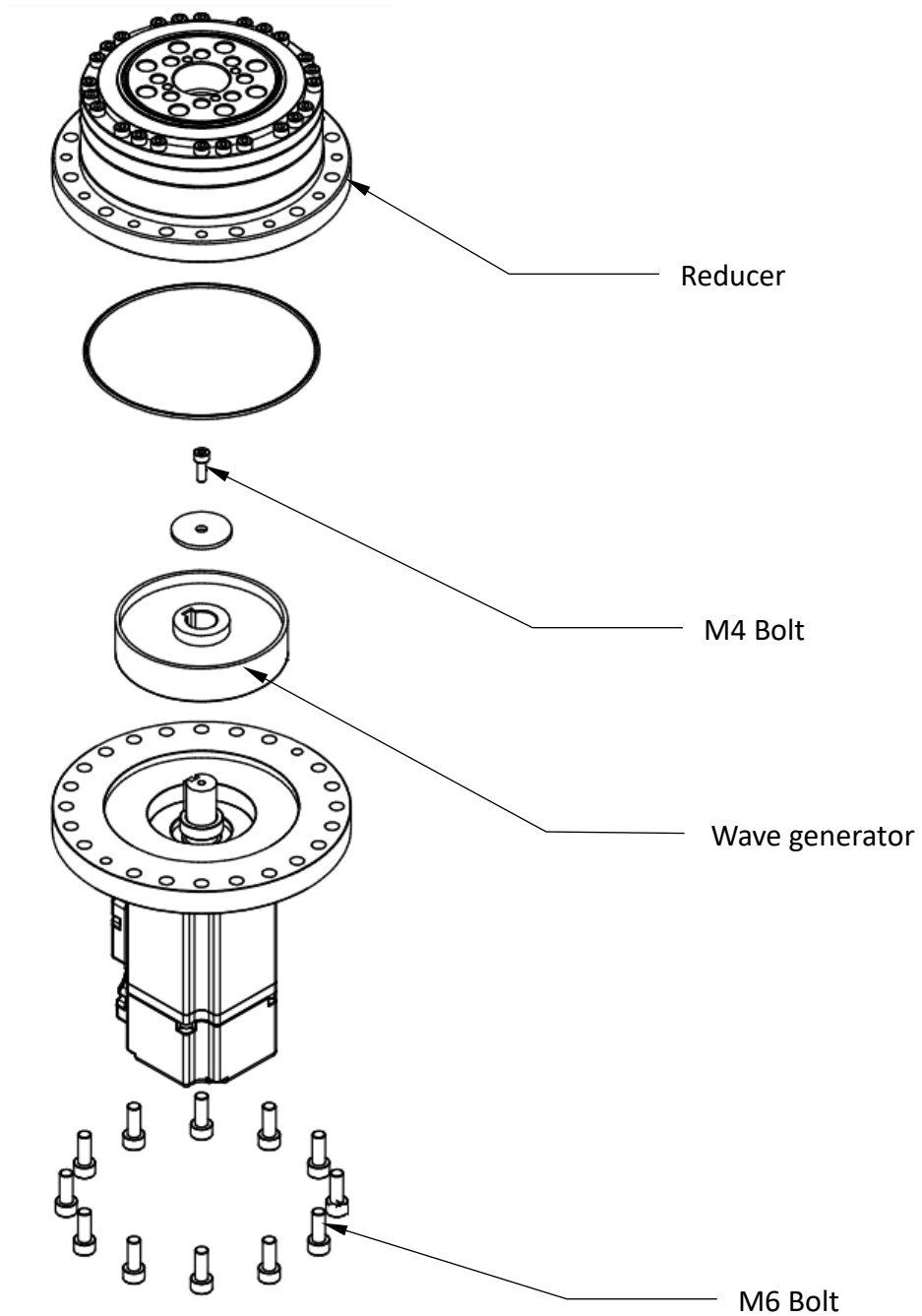

➤ J2 reducer disassembly

- Step1. Turn off the power of the controller.
- Step2. Remove the M4 bolts from the bolt cover.
- Step3. Remove the bolt cover on the A-arm.
- Step4. Remove the A-arm M8 bolts.
- Step5. Remove the B-arm.

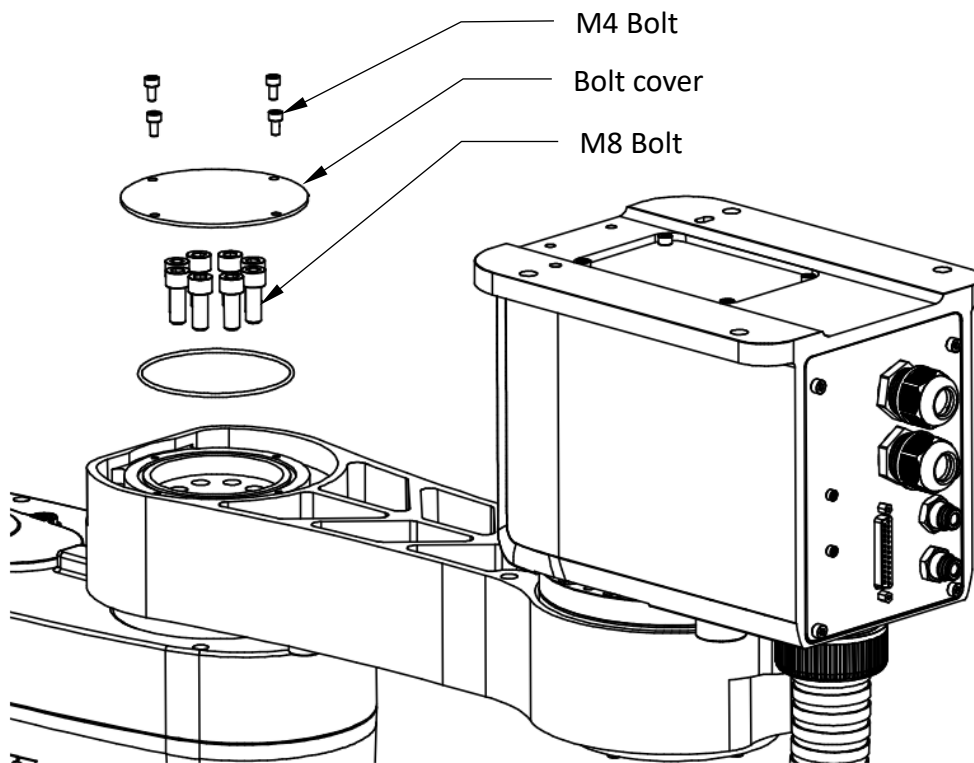

Step6. Remove the reducer flange M8 bolts.

Step7. Remove the J2 motor module vertically upwards.

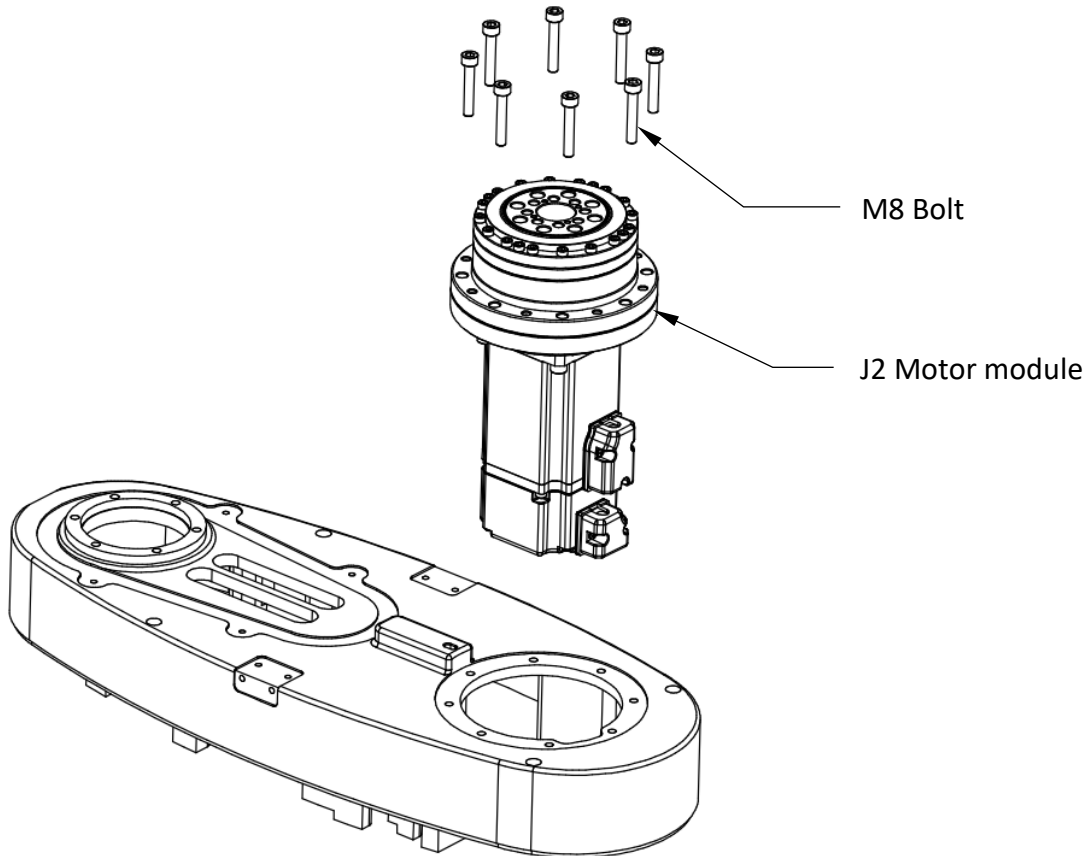

Step8. Remove the M3 bolt from the motor and wave generator

Step9. Remove the M6 bolts.

Step10. Separate the reducer, wave generator and motor in the axial direction.

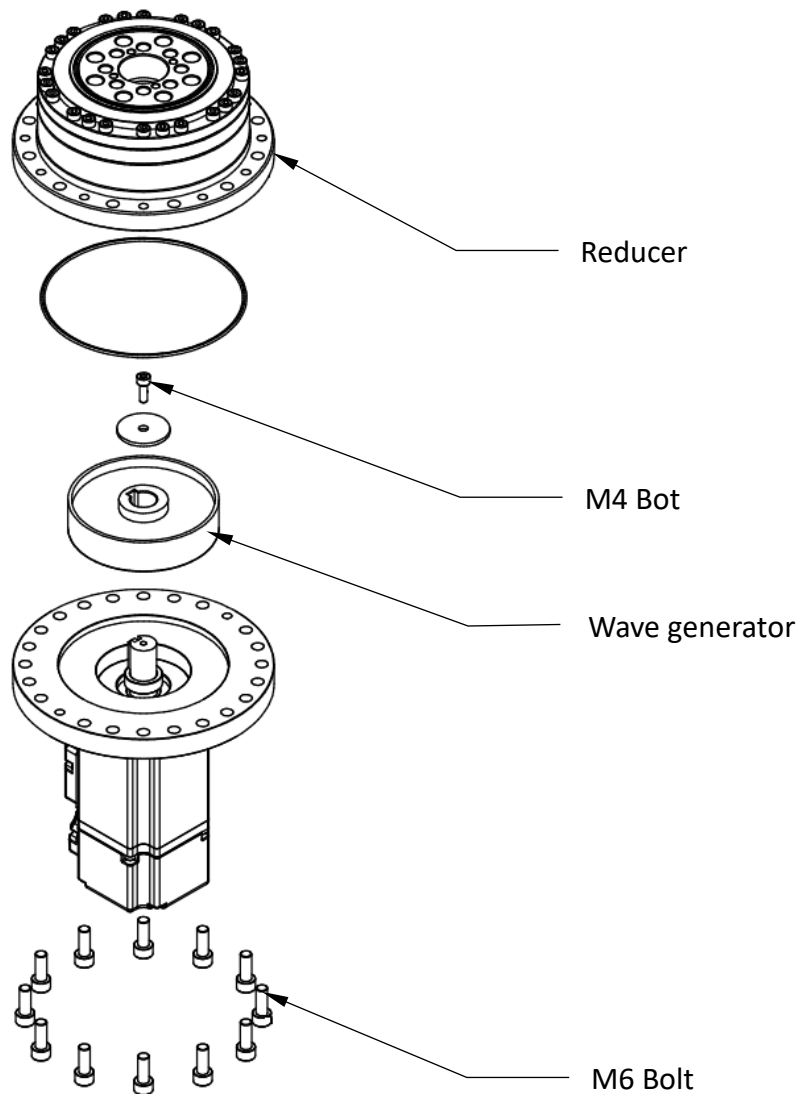

⚠ CAUTION

❖ When tightening the reducer, tighten the bolts with the torque wrench. The torque setting is as follows:

Spec.	Torque(N-m)	Torque (kgf-cm)
M3	2	20.4
M4	4.5	45.9
M5	9	91.8
M8	37	377.3

6. Robot/Controller Requirements form

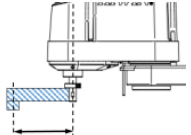
Customer information		Date:	
Company: Contact Person: Phone: Address:		Form completed by:	
Application	<input type="checkbox"/> Industry <input type="checkbox"/> Food <input type="checkbox"/> Medical <input type="checkbox"/> Other _____		
Maximum reach *	_____ mm	Payload*	_____ kg
Repeatability *	± _____ mm		
Distance *	_____ mm (The distance of the center of mass of the workpiece from ball spline)		
Cycle time*	_____ sec.		
J3 stroke*	<input type="checkbox"/> 200mm <input type="checkbox"/> 400mm		
Power type*	<input type="checkbox"/> Single phase 200V~240V <input type="checkbox"/> Other _____ V		
Power and signal cable length*	<input type="checkbox"/> 2m Other(optional): <input type="checkbox"/> 5m <input type="checkbox"/> 10m		
IP Protection grade	<input type="checkbox"/> IP20 Other(optional): <input type="checkbox"/> IP40		
Communication format	<input type="checkbox"/> Ethernet <input type="checkbox"/> RS-232 <input type="checkbox"/> Modbus-TCP(TCP/IP) Other(optional): <input type="checkbox"/> CC-Link <input type="checkbox"/> PROFINET <input type="checkbox"/> DeviceNet <input type="checkbox"/> EtherNet/IP		
Expansion module (optional)	<input type="checkbox"/> DO32 module <input type="checkbox"/> DI32 module <input type="checkbox"/> DI16 & DO16 module <input type="checkbox"/> Conveyor tracking module (encoder module 、 encoder 、 cable) <input type="checkbox"/> Ethernet Cable(3m)		
Other (optional)	<input type="checkbox"/> Emergency stop button switch (5m) <input type="checkbox"/> Bellow <input type="checkbox"/> Ball spline grease(G04) <input type="checkbox"/> Reducer grease(G11) <input type="checkbox"/> Gromet <input type="checkbox"/> I/O connector wiring set		
Recommended specification :		HIWIN adviser :	

Fields marked with an * are required.

7. Safety Certification

RS405/RS410 series have CE marking and it fulfill related Directives and ISO standards.

the corresponding directives and ISO standards of RA605-GC series

CE Compliance		
Machinery Directives(MD)	2006/42/EC	
	Safety of machinery — General principles for design — Risk assessment and risk reduction	EN ISO12100:2010
	Robots and robotic devices — Safety requirements for industrial robots — Part 1: Robots	EN ISO 10218-1:2011
Low Voltage Directives (LVD)	2014/35/EU	
	Safety of Machinery - Electrical equipment of machines - Part 1: General requirements	EN 60204-1:2018
Electromagnetic Compatibility Directives (EMC)	2014/30/EU	
	Generic standards - Immunity for industrial environments	EN 61000-6-2
	Generic standards. Emission standard for industrial environments	EN 61000-6-4
Restriction of Hazardous Substances Directive(RoHS)	2011/65/EU+(EU)/2015/863	
	Cd(100 ppm ↓) Pb,Hg,Cr ⁶⁺ ,PBB,PBDE,DEHP,DBP,BBP,DIBP(1000 ppm ↓)	

SCARA Robot- RS405-LU / RS410-LU (Original Instructions)

User Manual

Publication Date : September 2021

-
1. HIWIN is a registered trademark of HIWIN Technologies Corp.. For your protection, avoid buying counterfeit products from unknown sources.
 2. Actual products may differ from specifications and photos provided in this catalog. These differences may be the result of various factors including product improvements.
 3. HIWIN website for patented product directory: http://www.hiwin.tw/Products/Products_patents.aspx
 4. HIWIN will not sell or export products or processes restricted under the "Foreign Trade Act" or related regulations. Export of restricted products should be approved by proper authorities in accordance with relevant laws and shall not be used to manufacture or develop nuclear, biochemical, missiles or other weapons.



Global Sales And Customer Service Site

HIWIN GmbH

OFFENBURG, GERMANY
www.hiwin.de
www.hiwin.eu
info@hiwin.de

HIWIN JAPAN

KOBE · TOKYO · NAGOYA · NAGANO ·
TOHOKU · SHIZUOKA · HOKURIKU ·
HIROSHIMA · FUKUOKA · KUMAMOTO,
JAPAN
www.hiwin.co.jp
info@hiwin.co.jp

HIWIN USA

CHICAGO, U.S.A.
www.hiwin.us
info@hiwin.com

HIWIN Srl

BRUGHERIO, ITALY
www.hiwin.it
info@hiwin.it

HIWIN Schweiz GmbH

JONA, SWITZERLAND
www.hiwin.ch
info@hiwin.ch

HIWIN s.r.o.

BRNO, CZECH REPUBLIC
www.hiwin.cz
info@hiwin.cz

HIWIN FRANCE

STRASBOURG, FRANCE
www.hiwin.fr
info@hiwin.de

HIWIN SINGAPORE

SINGAPORE
www.hiwin.sg
info@hiwin.sg

HIWIN KOREA

SUWON · CHANGWON, KOREA
www.hiwin.kr
info@hiwin.kr

HIWIN CHINA

SUZHOU, CHINA
www.hiwin.cn
info@hiwin.cn

Mega-Fabs Motion Systems, Ltd.

HAIFA, ISRAEL
www.mega-fabs.com
info@mega-fabs.com

HIWIN TECHNOLOGIES CORP.

No. 7, Jingke Road,
Taichung Precision Machinery Park,
Taichung 40852, Taiwan
Tel: +886-4-23594510
Fax: +886-4-23594420
www.hiwin.tw
business@hiwin.tw (Sales)
robotservice@hiwin.tw (Customer Service)